



*empowering your ideas*

*for mobile, marine, mining and industrial applications*



**HYDRAULIC PRODUCTS**

*Highest Quality Components*



## WHO WE ARE

YOUNG POWERTECH Inc. and YOUNG POWERTECH CANADA LTD. are manufacturers and distributors of Mechanical, Hydraulics, Electric and Electronic assemblies for Construction, Farming, Marine, Mining and Industrial equipment.

YOUNG POWERTECH Inc. and YOUNG POWERTECH CANADA LTD. were started by people with decades of experience in the field that have owned and operated similar companies with great success. We are dedicated to bringing a higher level of products and services to our customers. With offices and warehouses in the USA and CANADA, YOUNG POWERTECH Inc. is prepared to service any customer requirements in North America.

We have partnered with some of the largest and best known manufacturers of several product lines. This enables YOUNG POWERTECH Inc. to supply drives systems from fractional HP to several thousand HP in every possible configuration to fit and improve most construction, farming, marine, mining, and industrial applications.

## OUR VISION

YOUNG POWERTECH Inc. seeks to become a preferred source for providing a complete and reliable engineering system from our product lines for our customers to reduce cost while improving system performance and customer satisfaction.

## OUR MISSION

Our mission is to provide long term value to our customers by delivering the best products and service while creating a mutually beneficial long term relationship with our stakeholders.

## Introduction

### COMPANY PROFILE

YOUNG POWERTECH Inc. supplies a full product range for power transmission and control.

In today's rapidly changing business environment, successful companies must have the flexibility and resources to meet the current and future needs of its customers. In our industry, we have the ability to supply advanced systems that are capable of performing in the most severe conditions. Our extensive product line allows us to supply complete packages or systems to improve equipment performance while minimizing the number of different suppliers that provide parts.

YOUNG POWERTECH Inc. has the products and the technical capability to "POWER YOUR IDEAS" by supplying one of the most complete ranges of products for any application. Our application engineering services help to validate that the design will meet the requirements of the customer.

### SUPPORT

Our partners manufacture very high quality products. We offer pre-sale and post-sale support and assistance if the customer experiences any issues with our products. A qualified network of sales professionals and technicians are available 24 hours per day around the world. Our goal is to resolve any issues in the shortest time possible as well as in the most professional manner.

### SERVICE

YOUNG POWERTECH Inc. with its partners around the globe ensures complete and continuous service all over the world. Our service organization consists of technical personnel and service centers that can support our customers 24 hours a day regardless of location. Our service centers have the resources to diagnose as well as make repairs.

## ORBITAL MOTORS GENERAL INFORMATION

### YMM

The smallest of the series with ROTOR and SHAFT DISTRIBUTION, is made to be used where small displacement, high speed and good performance is required.

### YMP - YMPH - YMPW

SHAFT Distribution and ROTOR type build with the most advanced technology used everywhere simplicity and low cost is required.

### YMR - YMRS

The smaller series with ROLLER gear type and spool valve distribution with high pressure seal that can operate without drain.

### YMH

With a SPOOL valve design and a ROLLER gear type this series is very versatile and with very high efficiency, very compact, high density power and suitable for many applications.

### YMER

This motor incorporates the ROLLER gear design and disc valve technology for maximum efficiency and smooth rotation. The shaft is supported by heavy duty needle bearing for high radial load.

### YMSY - YMSE - YMSS

The smallest series with ROLLER and DISC VALVE distribution, the YMS series has many advantages like LOW SPEED, HIGH VOLUMETRIC efficiency, smoother rotation and higher speed and pressure. Outputs shaft with tapered roller bearings for higher radial and axial load.

### YMT - YMTE - YMTS

This series of motors with advanced design ROLLER and self-balanced Disc Valve distribution with reduced frictions and very high efficiency, permits higher speed and pressure making it suitable for heavier duty applications. Also with standard high pressure seals can be used in series without drain line and shaft supported by Tapered roller bearings for high radial and axial load.

### YMV - YMVE

The largest series of our Orbital motor with standard HIGH pressure seals, ROLLER gear set and DISC valve, this motor can be used without drain line. The various options make them suitable for many applications.





## YMM

Distribution Type	Displacement		Max. Operating Pressure		Speed Range	Max. Output Power	
Spool Valve Distribution	[in <sup>3</sup> ./rev]	[.50~3.07]	[PSI]	[1450]	RPM	[HP]	[3]
	cm <sup>3</sup> /rev.	80 ~ 375	MPa	10	22~1950	Kw	2.4

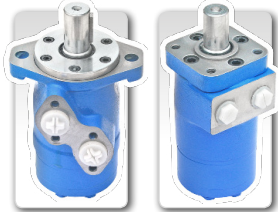

## YMP - YMPH - YMPW

Distribution Type	Displacement		Max. Operating Pressure		Speed Range	Max. Output Power	
Spool Valve Distribution	[in <sup>3</sup> ./rev]	[3.05~24.41]	[PSI]	[2400]	RPM	[HP]	[27]
	cm <sup>3</sup> /rev.	50 ~ 400	MPa	16.5	30~879	Kw	10

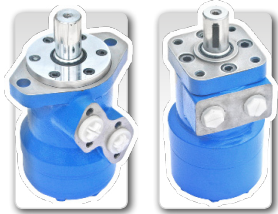

## YMR - YMRS

Distribution Type	Displacement		Max. Operating Pressure		Speed Range	Max. Output Power	
Spool Valve Distribution	[in <sup>3</sup> ./rev]	[3.05~22.88]	[PSI]	[2900]	RPM	[HP]	[20]
	cm <sup>3</sup> /rev.	50 ~ 375	MPa	20	30 ~ 970	Kw	17



## YMH

Distribution Type	Displacement		Max. Operating Pressure		Speed Range	Max. Output Power	
Spool Valve Distribution	[in <sup>3</sup> ./rev]	[3.05~24.41]	[PSI]	[2400]	RPM	[HP]	[27]
	cm <sup>3</sup> /rev.	50 ~ 400	MPa	16.5	30 ~ 879	Kw	10



## YMER

Distribution Type	Displacement		Max. Operating Pressure		Speed Range	Max. Output Power	
Disc Valve Distribution	[in <sup>3</sup> ./rev]	[4.88~22.88]	[PSI]	[3263]	RPM	[HP]	[27]
	cm <sup>3</sup> /rev.	80 ~ 375	MPa	22.5	30 ~ 800	Kw	20



## YMSY - YMSE - YMSS

Distribution Type	Displacement		Max. Operating Pressure		Speed Range	Max. Output Power	
Disc Valve Distribution	[in <sup>3</sup> ./rev]	[4.88~22.88]	[PSI]	[3263]	RPM	[HP]	[27]
	cm <sup>3</sup> /rev.	80 ~ 375	MPa	22.5	30 ~ 800	Kw	20

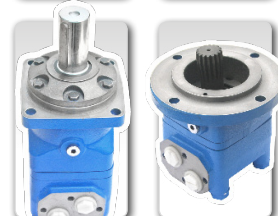

## YMT - YMTE - YMTS

Distribution Type	Displacement		Max. Operating Pressure		Speed Range	Max. Output Power	
Disc Valve Distribution	[in <sup>3</sup> ./rev]	[9.77~48.82]	[PSI]	[3480]	RPM	[HP]	[47]
	cm <sup>3</sup> /rev.	160 ~ 800	MPa	24	30 ~ 705	Kw	35



## YMV - YMVE

Distribution Type	Displacement		Max. Operating Pressure		Speed Range	Max. Output Power	
Disc Valve Distribution	[in <sup>3</sup> ./rev]	[19.23~48.82]	[PSI]	[4060]	RPM	[HP]	[58]
	cm <sup>3</sup> /rev.	315 ~ 800	MPa	28	10 ~ 446	Kw	43



## TECHNICAL DATA

DISTRIBUTION TYPE		YMM 8	YMM 12.5	YMM 20	YMM 32	YMM 40	YMM 50	
Geometric Displacement	[in <sup>3</sup> ./rev.]	[.50]	[.79]	[1.21]	[1.93]	[2.43]	[3.07]	
	cm <sup>3</sup> /rev.	<b>8.2</b>	<b>12.9</b>	<b>19.9</b>	<b>31.6</b>	<b>39.8</b>	<b>50.3</b>	
Max. Speed RPM	CONT.	1950	1550	1000	630	500	400	
	INT.	<b>2450</b>	<b>1940</b>	<b>1250</b>	<b>800</b>	<b>630</b>	<b>500</b>	
Max. Torque	CONT.	[LB. IN.]	[97]	[142]	[221]	[354]	[398]	[407]
		N*M	<b>11</b>	<b>16</b>	<b>25</b>	<b>40</b>	<b>45</b>	<b>46</b>
	INT.	[LB. IN.]	[133]	[203]	[310]	[504]	[619]	[778]
		N*M	<b>15</b>	<b>23</b>	<b>35</b>	<b>57</b>	<b>70</b>	<b>88</b>
	PEAK	[LB. IN.]	[186]	[292]	[451]	[566]	[725]	[884]
		N*M	<b>21</b>	<b>33</b>	<b>51</b>	<b>64</b>	<b>82</b>	<b>100</b>
Max. Output	CONT.	[HP]	[2.4]	[3.2]	[3.2]	[3.2]	[2.9]	[2.4]
		KW	<b>1.8</b>	<b>2.4</b>	<b>2.4</b>	<b>2.4</b>	<b>2.2</b>	<b>1.8</b>
	INT.	[HP]	[3.4]	[4.3]	[4.3]	[4.3]	[4.3]	[4.3]
		KW	<b>2.6</b>	<b>3.2</b>	<b>3.2</b>	<b>3.2</b>	<b>3.2</b>	<b>3.2</b>
Max. Pressure Drop	CONT.	[PSI]	[1450]	[1450]	[1450]	[1450]	[1305]	[1015]
		MPA	<b>10</b>	<b>10</b>	<b>10</b>	<b>10</b>	<b>9</b>	<b>7</b>
	INT.	[PSI]	[2030]	[2030]	[2030]	[2030]	[2030]	[2030]
		MPA	<b>14</b>	<b>14</b>	<b>14</b>	<b>14</b>	<b>14</b>	<b>14</b>
	PEAK	[PSI]	[2900]	[2900]	[2900]	[2320]	[2320]	[2320]
		MPA	<b>20</b>	<b>20</b>	<b>20</b>	<b>16</b>	<b>16</b>	<b>16</b>
Max. Flow	CONT.	[GPM]	[4.2]	[5.2]	[5.2]	[5.2]	[5.2]	[5.2]
		L/MIN	<b>16</b>	<b>20</b>	<b>20</b>	<b>20</b>	<b>20</b>	<b>20</b>
	INT.	[GPM]	[5.2]	[6.6]	[6.6]	[6.6]	[6.6]	[6.6]
		L/MIN	<b>20</b>	<b>25</b>	<b>25</b>	<b>25</b>	<b>25</b>	<b>25</b>
Weight	[LB]	[4]	[4]	[5]	[5]	[5]	[5]	
	KG	<b>1.9</b>	<b>2</b>	<b>2.1</b>	<b>2.2</b>	<b>2.3</b>	<b>2.4</b>	

- \* Continuous pressure:
- \* Intermittent pressure:
- \* Peak pressure:

Max. value of operating motor continuously.  
 Max. value of operating motor in 6 seconds per minute.  
 Max. value of operating motor in 0.6 second per minute.

**YMP**



**YMPH**



**YMPW**

## TECHNICAL DATA

DISTRIBUTION TYPE		YMP 36	YMP 50	YMP 80	YMP 100	YMP 125	YMP 160	YMP 200	YMP 250	YMP 315	YMP 400	
Geometric Displacement	[in <sup>3</sup> /rev.]	[2.20]	[3.15]	[4.74]	[5.87]	[7.19]	[9.49]	[11.59]	[14.10]	[19.01]	[23.57]	
	cm <sup>3</sup> /rev.	<b>36</b>	<b>51.7</b>	<b>77.7</b>	<b>96.2</b>	<b>117.9</b>	<b>155.5</b>	<b>189.9</b>	<b>231</b>	<b>311.7</b>	<b>386.2</b>	
Max. Speed RPM	CONT.	1078	879	740	589	475	370	296	237	189	149	
	INT.	<b>1210</b>	<b>975</b>	<b>827</b>	<b>673</b>	<b>594</b>	<b>463</b>	<b>370</b>	<b>297</b>	<b>236</b>	<b>185</b>	
Max. Torque	CONT.	[LB. IN.]	[486]	[716]	[1141]	[1423]	[1786]	[2167]	[2529]	[3184]	[3591]	[4847]
		<b>N*M</b>	<b>55</b>	<b>81</b>	<b>129</b>	<b>161</b>	<b>202</b>	<b>245</b>	<b>286</b>	<b>360</b>	<b>406</b>	<b>435</b>
	INT.	[LB. IN.]	[672]	[955]	[1512]	[1884]	[2370]	[3025]	[3449]	[4033]	[4466]	[4714]
		<b>N*M</b>	<b>76</b>	<b>108</b>	<b>171</b>	<b>213</b>	<b>268</b>	<b>342</b>	<b>390</b>	<b>456</b>	<b>505</b>	<b>533</b>
Max. Output	CONT.	[HP]	[8]	[9]	[12]	[12]	[12]	[12]	[11]	[11]	[10]	[10]
		<b>KW</b>	<b>6</b>	<b>7</b>	<b>9.1</b>	<b>9</b>	<b>9.1</b>	<b>8.7</b>	<b>8.1</b>	<b>8.2</b>	<b>7.2</b>	<b>6.1</b>
	INT.	[HP]	[10]	[12]	[16]	[16]	[16]	[16]	[15]	[14]	[12]	[10]
		<b>KW</b>	<b>8</b>	<b>8.9</b>	<b>11.8</b>	<b>11.9</b>	<b>11.8</b>	<b>11.9</b>	<b>10.9</b>	<b>10.1</b>	<b>8.6</b>	<b>7.2</b>
Max. Pressure Drop	CONT.	[PSI]	[1812]	[1812]	[1812]	[1812]	[1812]	[1812]	[1595]	[1595]	[1595]	[1450]
		<b>MPa</b>	<b>12.5</b>	<b>12.5</b>	<b>12.5</b>	<b>12.5</b>	<b>12.5</b>	<b>12.5</b>	<b>12.5</b>	<b>11</b>	<b>11</b>	<b>11</b>
	INT.	[PSI]	[2392]	[2392]	[2392]	[2392]	[2392]	[2392]	[2392]	[2030]	[1812]	[1522]
		<b>MPa</b>	<b>16.5</b>	<b>16.5</b>	<b>16.5</b>	<b>16.5</b>	<b>16.5</b>	<b>16.5</b>	<b>16.5</b>	<b>14</b>	<b>12.5</b>	<b>10.5</b>
	PEAK	[PSI]	[2392]	[2392]	[2392]	[2392]	[2392]	[2392]	[2392]	[2030]	[1812]	[1522]
		<b>MPa</b>	<b>16.5</b>	<b>16.5</b>	<b>16.5</b>	<b>16.5</b>	<b>16.5</b>	<b>16.5</b>	<b>16.5</b>	<b>14</b>	<b>12.5</b>	<b>10.5</b>
Max. Flow	CONT.	[GPM]	[10.4]	[11.8]	[15.8]	[15.8]	[15.8]	[15.8]	[15.8]	[15.8]	[15.8]	[15.8]
		<b>L/MIN</b>	<b>40</b>	<b>45</b>	<b>60</b>	<b>60</b>	<b>60</b>	<b>60</b>	<b>60</b>	<b>60</b>	<b>60</b>	<b>60</b>
	INT.	[GPM]	[11.8]	[13.2]	[19.8]	[19.8]	[19.8]	[19.8]	[19.8]	[19.8]	[19.8]	[19.8]
		<b>L/MIN</b>	<b>45</b>	<b>50</b>	<b>75</b>	<b>75</b>	<b>75</b>	<b>75</b>	<b>75</b>	<b>75</b>	<b>75</b>	<b>75</b>
Weight	[LB]	[12]	[12]	[13]	[13]	[13]	[14]	[14]	[15]	[15]	[16]	
	<b>KG</b>	<b>5.6</b>	<b>5.6</b>	<b>5.7</b>	<b>5.9</b>	<b>6</b>	<b>6.2</b>	<b>6.4</b>	<b>6.6</b>	<b>6.9</b>	<b>7.4</b>	

- \* Continuous pressure:
- \* Intermittent pressure:
- \* Peak pressure:

Max. value of operating motor continuously.  
 Max. value of operating motor in 6 seconds per minute.  
 Max. value of operating motor in 0.6 second per minute.

**YMP**



## TECHNICAL DATA

DISTRIBUTION TYPE		YMR 50	YMR 80	YMR 100	YMR 125	YMR 160	YMR 200	YMR 250	YMR 315	YMR 375	
<b>Geometric Displacement</b>	[in <sup>3</sup> ./rev.]	[3.13]	[4.92]	[6.15]	[7.62]	[9.59]	[12.16]	[15.38]	[19.19]	[22.58]	
	cm <sup>3</sup> /rev.	<b>51.3</b>	<b>80.6</b>	<b>100.8</b>	<b>124.9</b>	<b>157.2</b>	<b>199.2</b>	<b>252</b>	<b>314.5</b>	<b>370</b>	
<b>Max. Speed RPM</b>	CONT.	<b>970</b>	<b>940</b>	<b>750</b>	<b>600</b>	<b>470</b>	<b>375</b>	<b>300</b>	<b>240</b>	<b>200</b>	
<b>Max. Torque</b>	CONT.	[LB. IN.]	[884]	[1680]	[2123]	[2582]	[3210]	[3166]	[3113]	[3184]	[3714]
		<b>N*M</b>	<b>100</b>	<b>190</b>	<b>240</b>	<b>292</b>	<b>363</b>	<b>358</b>	<b>352</b>	<b>360</b>	<b>420</b>
	INT.	[LB. IN.]	[1114]	[1946]	[2476]	[3007]	[3803]	[3962]	[4157]	[4157]	[4847]
		<b>N*M</b>	<b>126</b>	<b>220</b>	<b>280</b>	<b>340</b>	<b>430</b>	<b>448</b>	<b>470</b>	<b>470</b>	<b>548</b>
<b>Max. Output</b>	CONT.	[HP]	[10]	[20]	[20]	[19]	[19]	[15]	[12]	[9]	[12]
		<b>KW</b>	<b>7.7</b>	<b>15</b>	<b>15</b>	<b>14</b>	<b>14</b>	<b>11</b>	<b>9</b>	<b>7</b>	<b>8.6</b>
	INT.	[HP]	[13]	[23]	[23]	[22]	[22]	[19]	[16]	[12]	[16]
		<b>KW</b>	<b>9.7</b>	<b>17</b>	<b>17</b>	<b>16</b>	<b>16</b>	<b>14</b>	<b>12</b>	<b>9</b>	<b>12</b>
<b>Max. Pressure Drop</b>	CONT.	[PSI]	[2030]	[2537]	[2537]	[2537]	[2392]	[1885]	[1595]	[1232]	[1232]
		<b>MPa</b>	<b>14</b>	<b>17.5</b>	<b>17.5</b>	<b>17.5</b>	<b>16.5</b>	<b>13</b>	<b>11</b>	<b>8.5</b>	<b>8.5</b>
	INT.	[PSI]	[2537]	[2900]	[2900]	[2900]	[2900]	[2537]	[2030]	[1667]	[1667]
		<b>MPa</b>	<b>17.5</b>	<b>20</b>	<b>20</b>	<b>20</b>	<b>20</b>	<b>17.5</b>	<b>14</b>	<b>11.5</b>	<b>11.5</b>
<b>Max. Flow</b>	CONT.	[GPM]	[10.6]	[15.8]	[15.8]	[15.8]	[15.8]	[15.8]	[15.8]	[15.8]	[15.8]
		<b>L/MIN</b>	<b>40</b>	<b>60</b>	<b>60</b>	<b>60</b>	<b>60</b>	<b>60</b>	<b>60</b>	<b>60</b>	<b>60</b>
	INT.	[GPM]	[13.2]	[19.8]	[19.8]	[19.8]	[19.8]	[19.8]	[19.8]	[19.8]	[19.8]
		<b>L/MIN</b>	<b>50</b>	<b>75</b>	<b>75</b>	<b>75</b>	<b>75</b>	<b>75</b>	<b>75</b>	<b>75</b>	<b>75</b>
<b>Weight</b>	[LB]	[15]	[15]	[15]	[16]	[17]	[18]	[19]	[20]	[20]	
	<b>KG</b>	<b>6.7</b>	<b>6.9</b>	<b>6.9</b>	<b>7.2</b>	<b>7.5</b>	<b>8</b>	<b>8.5</b>	<b>9</b>	<b>9.3</b>	

\* Continuous pressure:

\* Intermittent pressure:

\* Peak pressure:

Max. value of operating motor continuously.

Max. value of operating motor in 6 seconds per minute.

Max. value of operating motor in 0.6 second per minute.





## TECHNICAL DATA

DISTRIBUTION TYPE		YMH 200	YMH 250	YMH 315	YMH 400	YMH 500	
<b>Geometric Displacement</b>	[in <sup>3</sup> ./rev.]	[12.40]	[15.62]	[19.29]	[24.80]	[29.86]	
	cm <sup>3</sup> /rev.	<b>203.2</b>	<b>255.9</b>	<b>316.1</b>	<b>406.4</b>	<b>489.2</b>	
<b>Max. Speed RPM</b>	CONT.	366	290	236	183	155	
	<b>INT.</b>	<b>439</b>	<b>348</b>	<b>282</b>	<b>220</b>	<b>166</b>	
<b>Max. Torque</b>	CONT.	[LB. IN.]	[4510]	[5492]	[6545]	[7641]	[7066]
		<b>N*M</b>	<b>510</b>	<b>621</b>	<b>740</b>	<b>864</b>	<b>799</b>
	INT.	[LB. IN.]	[5121]	[6208]	[7314]	[8738]	[8588]
		<b>N*M</b>	<b>579</b>	<b>702</b>	<b>827</b>	<b>988</b>	<b>971</b>
	PEAK	[LB. IN.]	[5757]	[6987]	[8225]	[9658]	[9658]
		<b>N*M</b>	<b>651</b>	<b>790</b>	<b>930</b>	<b>1092</b>	<b>1092</b>
<b>Max. Output</b>	CONT.	[HP]	[15]	[12]	[13]	[10]	[9]
		<b>KW</b>	<b>11.2</b>	<b>9.2</b>	<b>9.8</b>	<b>7.4</b>	<b>6.5</b>
	INT.	[HP]	[23]	[20]	[17]	[17]	[15]
		<b>KW</b>	<b>17</b>	<b>15</b>	<b>13</b>	<b>13</b>	<b>11</b>
<b>Max. Pressure Drop</b>	CONT.	[PSI]	[2538]	[2538]	[2538]	[2248]	[1813]
		<b>MPa</b>	<b>17.5</b>	<b>17.5</b>	<b>17.5</b>	<b>15.5</b>	<b>12.5</b>
	INT.	[PSI]	[2900]	[2900]	[2900]	[2755]	[2320]
		<b>MPa</b>	<b>20</b>	<b>20</b>	<b>20</b>	<b>19</b>	<b>16</b>
	PEAK	[PSI]	[3263]	[3263]	[3263]	[3045]	[2610]
		<b>MPa</b>	<b>22.5</b>	<b>22.5</b>	<b>22.5</b>	<b>21</b>	<b>18</b>
<b>Max. Flow</b>	CONT.	[GPM]	[19.8]	[19.8]	[19.8]	[19.8]	[19.8]
		<b>L/MIN</b>	<b>75</b>	<b>75</b>	<b>75</b>	<b>75</b>	<b>75</b>
	INT.	[GPM]	[23.7]	[23.7]	[23.7]	[23.7]	[23.7]
		<b>L/MIN</b>	<b>90</b>	<b>90</b>	<b>90</b>	<b>90</b>	<b>90</b>
<b>Weight</b>	[LB]	[23]	[24]	[25]	[27]	[29]	
	<b>KG</b>	<b>10.5</b>	<b>11</b>	<b>11.5</b>	<b>12.3</b>	<b>13</b>	

- \* Continuous pressure:
- \* Intermittent pressure:
- \* Peak pressure:

Max. value of operating motor continuously.  
 Max. value of operating motor in 6 seconds per minute.  
 Max. value of operating motor in 0.6 second per minute.

YMH

## YMER



### TECHNICAL DATA

DISTRIBUTION TYPE		YMER 125	YMER 160	YMER 200	YMER 230	YMER 250	YMER 300	YMER 350	YMER 375	YMER 475	YMER 540	YMER 750	
Geometric Displacement	cm <sup>3</sup> /rev	118	156	196	228	257	296	345	371	462	540	745	
	[in <sup>3</sup> /rev]	<b>7.20</b>	<b>9.52</b>	<b>12</b>	<b>13.91</b>	<b>15.7</b>	<b>18.1</b>	<b>21.1</b>	<b>22.6</b>	<b>28.2</b>	<b>33</b>	<b>45.5</b>	
Max. Speed	cont. rpm	360	375	330	290	290	250	220	200	160	140	100	
	int. rpm	<b>490</b>	<b>470</b>	<b>425</b>	<b>365</b>	<b>350</b>	<b>315</b>	<b>270</b>	<b>240</b>	<b>195</b>	<b>170</b>	<b>120</b>	
Max. Torque	cont.	N*M	325	450	530	625	700	810	905	990	1085	980	1050
		[lb./in.]	<b>[2876]</b>	<b>[3983]</b>	<b>[4691]</b>	<b>[5532]</b>	<b>[6196]</b>	<b>[7169]</b>	<b>[8010]</b>	<b>[8762]</b>	<b>[9603]</b>	<b>[8674]</b>	<b>[9293]</b>
	int.	N*M	380	525	600	710	790	930	1035	1140	1180	1240	1180
		[lb./in.]	<b>[3363]</b>	<b>[4647]</b>	<b>[5310]</b>	<b>[6284]</b>	<b>[6692]</b>	<b>[8231]</b>	<b>[9161]</b>	<b>[10090]</b>	<b>[10444]</b>	<b>[10975]</b>	<b>[10444]</b>
peak	N*M	450	590	750	870	980	1120	1285	1360	1260	1380	1370	
	[lb./in.]	<b>[3983]</b>	<b>[5222]</b>	<b>[6638]</b>	<b>[7700]</b>	<b>[8674]</b>	<b>[9913]</b>	<b>[11373]</b>	<b>[12037]</b>	<b>[11152]</b>	<b>[12214]</b>	<b>[12126]</b>	
Max. Output	cont.	KW	12.0	15.0	15.5	16.0	17.5	18.0	17.5	16.5	14.5	11.5	8.0
		[HP]	<b>[16.0]</b>	<b>[20.1]</b>	<b>[20.7]</b>	<b>[21.4]</b>	<b>[23.5]</b>	<b>[24.1]</b>	<b>[23.5]</b>	<b>[22.1]</b>	<b>[19.4]</b>	<b>[15.4]</b>	<b>[10.7]</b>
	int.	KW	14.0	17.5	18.0	19.0	20.0	21.0	20.0	19.0	16.5	15.0	10.0
		[HP]	<b>[18.8]</b>	<b>[23.5]</b>	<b>[24.1]</b>	<b>[25.5]</b>	<b>[26.8]</b>	<b>[28.2]</b>	<b>[26.8]</b>	<b>[25.5]</b>	<b>[22.1]</b>	<b>[20.1]</b>	<b>[13.4]</b>
Max. Pressure Drop	cont.	MPa	20.5	20.5	20.5	20.5	20.5	20.5	20.5	20.5	17.5	14	10.5
		[PSI]	<b>[2973]</b>	<b>[2973]</b>	<b>[2973]</b>	<b>[2973]</b>	<b>[2973]</b>	<b>[2973]</b>	<b>[2973]</b>	<b>[2973]</b>	<b>[2538]</b>	<b>[2030]</b>	<b>[1523]</b>
	int.	MPa	24	24	24	24	24	24	24	24	19	17.5	12
		[PSI]	<b>[3480]</b>	<b>[3480]</b>	<b>[3480]</b>	<b>[3480]</b>	<b>[3480]</b>	<b>[3480]</b>	<b>[3480]</b>	<b>[3480]</b>	<b>[2755]</b>	<b>[2538]</b>	<b>[1740]</b>
	peak	MPa	27.6	27.6	27.6	27.6	27.6	27.6	27.6	27.6	20.5	20.5	14
		[PSI]	<b>[4000]</b>	<b>[4000]</b>	<b>[4000]</b>	<b>[4000]</b>	<b>[4000]</b>	<b>[4000]</b>	<b>[4000]</b>	<b>[4000]</b>	<b>[2973]</b>	<b>[2973]</b>	<b>[2030]</b>
Max. Flow	cont.	l/min	45	60	70	70	75	80	80	75	75	75	75
		[GPM]	<b>[11.9]</b>	<b>[15.9]</b>	<b>[18.5]</b>	<b>[18.5]</b>	<b>[19.8]</b>	<b>[21.1]</b>	<b>[21.1]</b>	<b>[19.8]</b>	<b>[19.8]</b>	<b>[19.8]</b>	<b>[19.8]</b>
	int.	l/min	60	75	85	85	90	95	95	90	90	90	90
		[GPM]	<b>[15.9]</b>	<b>[19.8]</b>	<b>[22.5]</b>	<b>[22.5]</b>	<b>[23.8]</b>	<b>[25.1]</b>	<b>[25.1]</b>	<b>[23.8]</b>	<b>[23.8]</b>	<b>[23.8]</b>	<b>[23.8]</b>

- \* Continuous pressure:
- \* Intermittent pressure:
- \* Peak pressure:

Max. value of operating motor continuously.  
 Max. value of operating motor in 6 seconds per minute.  
 Max. value of operating motor in 0.6 second per minute.



**YMSE**

**YMSS**



## TECHNICAL DATA

DISTRIBUTION TYPE		YMSY 80	YMSY 100	YMSY 125	YMSY 160	YMSY 200	YMSY 250	YMSY 315	YMSY 400	YMSY 475	
<b>Geometric Displacement</b>	[in <sup>3</sup> ./rev.]	[4.92]	[6.15]	[7.63]	[9.40]	[11.84]	[14.83]	[18.97]	[24.04]	[28.98]	
	cm <sup>3</sup> /rev.	<b>80.6</b>	<b>100.8</b>	<b>125</b>	<b>154</b>	<b>194</b>	<b>243</b>	<b>311</b>	<b>394</b>	<b>475</b>	
<b>Max. Speed RPM</b>	CONT.	800	748	600	470	375	300	240	185	155	
	INT.	988	900	720	560	450	360	280	225	185	
<b>Max. Torque</b>	CONT.	[LB. IN.]	[1990]	[2565]	[3228]	[4289]	[5183]	[6262]	[7783]	[7783]	[8048]
		<b>N*M</b>	<b>225</b>	<b>290</b>	<b>365</b>	<b>485</b>	<b>586</b>	<b>708</b>	<b>880</b>	<b>880</b>	<b>910</b>
	INT.	[LB. IN.]	[2211]	[2830]	[3538]	[4776]	[5704]	[7128]	[8490]	[8490]	[8490]
		<b>N*M</b>	<b>250</b>	<b>320</b>	<b>400</b>	<b>540</b>	<b>645</b>	<b>806</b>	<b>960</b>	<b>960</b>	<b>960</b>
<b>Max. Output</b>	CONT.	[HP]	[21]	[24]	[24]	[24]	[24]	[23]	[15]	[12]	
		<b>KW</b>	<b>16</b>	<b>18</b>	<b>18</b>	<b>18.1</b>	<b>18.1</b>	<b>18</b>	<b>17</b>	<b>11</b>	<b>9</b>
	INT.	[HP]	[27]	[29]	[31]	[34]	[32]	[32]	[27]	[16]	[15]
		<b>KW</b>	<b>20</b>	<b>22</b>	<b>23</b>	<b>25</b>	<b>24</b>	<b>23.8</b>	<b>20.2</b>	<b>12</b>	<b>11</b>
<b>Max. Pressure Drop</b>	CONT.	[PSI]	[2913]	[2913]	[2913]	[3045]	[3045]	[2900]	[2900]	[2320]	[2030]
		<b>MPA</b>	<b>20.5</b>	<b>20.5</b>	<b>20.5</b>	<b>21</b>	<b>21</b>	<b>20</b>	<b>20</b>	<b>16</b>	<b>14</b>
	INT.	[PSI]	[3263]	[3263]	[3263]	[3263]	[3263]	[3263]	[3263]	[2538]	[2175]
		<b>MPA</b>	<b>22.5</b>	<b>22.5</b>	<b>22.5</b>	<b>22.5</b>	<b>22.5</b>	<b>22.5</b>	<b>22.5</b>	<b>17.5</b>	<b>15</b>
	PEAK	[PSI]	[4278]	[4278]	[4278]	[3263]	[3263]	[3263]	[3263]	[2900]	[2538]
		<b>MPA</b>	<b>29.5</b>	<b>29.5</b>	<b>29.5</b>	<b>22.5</b>	<b>22.5</b>	<b>22.5</b>	<b>22.5</b>	<b>20</b>	<b>17.5</b>
<b>Max. Flow</b>	CONT.	[GPM]	[17.17]	[19.8]	[19.8]	[19.8]	[19.8]	[19.8]	[19.8]	[19.8]	
		<b>L/MIN</b>	<b>65</b>	<b>75</b>	<b>75</b>	<b>75</b>	<b>75</b>	<b>75</b>	<b>75</b>	<b>75</b>	<b>75</b>
	INT.	[GPM]	[21.14]	[23.7]	[23.7]	[23.7]	[23.7]	[23.7]	[23.7]	[23.7]	[23.7]
		<b>L/MIN</b>	<b>80</b>	<b>90</b>	<b>90</b>	<b>90</b>	<b>90</b>	<b>90</b>	<b>90</b>	<b>90</b>	<b>90</b>
<b>Max. Inlet Pressure</b>	CONT.	[PSI]	[3265]	[3265]	[3265]	[3265]	[3265]	[3265]	[3265]	[3265]	
		<b>MPA</b>	<b>25</b>	<b>25</b>	<b>25</b>	<b>25</b>	<b>25</b>	<b>25</b>	<b>25</b>	<b>25</b>	<b>25</b>
	INT.	[PSI]	[4350]	[4350]	[4350]	[4350]	[4350]	[4350]	[4350]	[4350]	[4350]
		<b>MPA</b>	<b>30</b>	<b>30</b>	<b>30</b>	<b>30</b>	<b>30</b>	<b>30</b>	<b>30</b>	<b>30</b>	<b>30</b>
<b>Weight</b>	[LB]	[22]	[22.4]	[23]	[24]	[24]	[26]	[27]	[29]	[31]	
	<b>KG</b>	<b>9.8</b>	<b>10</b>	<b>10.3</b>	<b>10.7</b>	<b>11.1</b>	<b>11.6</b>	<b>12.3</b>	<b>13.2</b>	<b>14.3</b>	

- \* Continuous pressure:
- \* Intermittent pressure:
- \* Peak pressure:

Max. value of operating motor continuously.  
 Max. value of operating motor in 6 seconds per minute.  
 Max. value of operating motor in 0.6 second per minute.

YMSY

**YMT**



**YMTE**

**YMTS**



## TECHNICAL DATA

Distribution Type		YMT 160	YMT 200	YMT 250	YMT 315	YMT 400	YMT 500	YMT 630	YMT 800	
<b>Geometric Displacement</b>	[in <sup>3</sup> /rev.]	[9.83]	[12.29]	[15.37]	[19.92]	[25.08]	[31.96]	[38.39]	[48.93]	
	cm <sup>3</sup> /rev.	<b>161.1</b>	<b>201.4</b>	<b>251.8</b>	<b>326.3</b>	<b>410.9</b>	<b>523.6</b>	<b>629.1</b>	<b>801.8</b>	
<b>Max. Speed RPM</b>	CONT.	614	615	495	380	302	237	196	154	
	INT.	770	743	592	458	364	284	233	185	
<b>Max. Torque</b>	CONT.	[IN. LB.]	[4166]	[5209]	[6430]	[8508]	[9684]	[11.011]	[11.656]	[12.948]
		<b>N*M</b>	<b>471</b>	<b>589</b>	<b>727</b>	<b>962</b>	<b>1095</b>	<b>1245</b>	<b>1318</b>	<b>1464</b>
	INT.	[IN. LB.]	[507]	[6350]	[7853]	[10.206]	[11.223]	[12.461]	[13.248]	[13.443]
		<b>N*M</b>	<b>57.3</b>	<b>718</b>	<b>888</b>	<b>1154</b>	<b>1269</b>	<b>1409</b>	<b>1498</b>	<b>1520</b>
	PEAK	[IN.LB]	[5917]	[7411]	[9162]	[11.907]	[12.826]	[14.538]	[14.317]	[1725]
		<b>N*M</b>	<b>669</b>	<b>838</b>	<b>1036</b>	<b>1346.3</b>	<b>1450.3</b>	<b>1643.8</b>	<b>1618.8</b>	<b>1665</b>
<b>Max. Output</b>	CONT.	[HP]	[37.1]	[46.8]	[46.2]	[46.8]	[41.8]	[38.6]	[33.9]	[29.8]
		<b>KW</b>	<b>27.7</b>	<b>34.9</b>	<b>34.5</b>	<b>34.9</b>	<b>31.2</b>	<b>28.8</b>	<b>25.3</b>	<b>22.2</b>
	INT.	[HP]	[42.9]	[53.6]	[53.6]	[53.6]	[46.9]	[46.9]	[36.8]	[35.9]
		<b>KW</b>	<b>32</b>	<b>40</b>	<b>40</b>	<b>40</b>	<b>35</b>	<b>35</b>	<b>27.5</b>	<b>26.8</b>
<b>Max. Pressure Drop</b>	CONT.	[PSI]	[2900]	[2900]	[2900]	[2900]	[2610]	[2320]	[2030]	[1813]
		<b>MPA</b>	<b>20</b>	<b>20</b>	<b>20</b>	<b>20</b>	<b>18</b>	<b>16</b>	<b>14</b>	<b>12.5</b>
	INT.	[PSI]	[3480]	[3480]	[3480]	[3480]	[3045]	[2610]	[2320]	[1885]
		<b>MPA</b>	<b>24</b>	<b>24</b>	<b>24</b>	<b>24</b>	<b>21</b>	<b>18</b>	<b>16</b>	<b>13</b>
	PEAK	[PSI]	[4060]	[4060]	[4060]	[4060]	[3480]	[3045]	[2755]	[2320]
		<b>MPA</b>	<b>28</b>	<b>28</b>	<b>28</b>	<b>28</b>	<b>24</b>	<b>21</b>	<b>19</b>	<b>16</b>
<b>Max. Flow</b>	CONT.	[GPM]	[26.4]	[33]	[33]	[33]	[33]	[33]	[33]	[33]
		<b>L/MIN</b>	<b>100</b>	<b>125</b>	<b>125</b>	<b>125</b>	<b>125</b>	<b>125</b>	<b>125</b>	<b>125</b>
	INT.	[GPM]	[33]	[39.6]	[39.6]	[39.6]	[39.6]	[39.6]	[39.6]	[39.6]
		<b>L/MIN</b>	<b>125</b>	<b>150</b>	<b>150</b>	<b>150</b>	<b>150</b>	<b>150</b>	<b>150</b>	<b>150</b>
<b>Man. Inlet Pressure</b>	CONT.	[PSI]	[3045]	[3045]	[3045]	[3045]	[3045]	[3045]	[3045]	[3045]
		<b>MPA</b>	<b>21</b>	<b>21</b>	<b>21</b>	<b>21</b>	<b>21</b>	<b>21</b>	<b>21</b>	<b>21</b>
	INT.	[PSI]	[3625]	[3625]	[3625]	[3625]	[3625]	[3625]	[3625]	[3625]
		<b>MPA</b>	<b>25</b>	<b>25</b>	<b>25</b>	<b>25</b>	<b>25</b>	<b>25</b>	<b>25</b>	<b>25</b>
	PEAK	[PSI]	[4350]	[4350]	[4350]	[4350]	[4350]	[4350]	[4350]	[4350]
		<b>MPA</b>	<b>30</b>	<b>30</b>	<b>30</b>	<b>30</b>	<b>30</b>	<b>30</b>	<b>30</b>	<b>30</b>
<b>Weight</b>	[LB]	[43]	[44]	[45]	[46]	[48]	[52]	[53]	[55]	
	<b>KG</b>	<b>19.5</b>	<b>20</b>	<b>20.5</b>	<b>21</b>	<b>22</b>	<b>23</b>	<b>24</b>	<b>25</b>	

- \* Continuous pressure:
- \* Intermittent pressure:
- \* Peak pressure:

Max. value of operating motor continuously.  
 Max. value of operating motor in 6 seconds per minute.  
 Max. value of operating motor in 0.6 second per minute.



**YMV**



**YMVE**

**YMVS**



## TECHNICAL DATA

DISTRIBUTION TYPE		YMV 315	YMV 400	YMV 500	YMV 630	YMV 800	YMV 1000	
<b>Geometric Displacement</b>	[in <sup>3</sup> ./rev.]	[20.32]	[25.57]	[31.61]	[40.63]	[48.88]	[60.40]	
	<b>cm<sup>3</sup>/rev.</b>	<b>333</b>	<b>419</b>	<b>518</b>	<b>666</b>	<b>801</b>	<b>990</b>	
<b>Max. Speed RPM</b>	CONT.	446	354	386	223	185	145	
	INT.	649	526	425	331	275	220	
<b>Max. Torque</b>	CONT.	[IN. LB.]	[8181]	[10790]	[12824]	[14504]	[16008]	[17821]
		<b>N*M</b>	<b>925</b>	<b>1220</b>	<b>1450</b>	<b>1640</b>	<b>1810</b>	<b>2015</b>
	INT.	[IN. LB.]	[9728]	[12727]	[15742]	[17688]	[18661]	[20164]
		<b>N*M</b>	<b>1100</b>	<b>1439</b>	<b>1780</b>	<b>2000</b>	<b>2110</b>	<b>2280</b>
	PEAK	[IN. LB.]	[11931]	[15035]	[18758]	[20677]	[21845]	[21226]
		<b>N*M</b>	<b>1349</b>	<b>1700</b>	<b>2121</b>	<b>2338</b>	<b>2470</b>	<b>2400</b>
<b>Max. Output</b>	CONT.	[HP]	[58]	[61]	[78]	[52]	[47]	[38]
		<b>KW</b>	<b>43</b>	<b>45.2</b>	<b>58.6</b>	<b>38.3</b>	<b>35.1</b>	<b>28.6</b>
	INT.	[HP]	[70]	[70]	[70]	[62]	[54]	[54]
		<b>KW</b>	<b>52</b>	<b>52</b>	<b>52</b>	<b>46</b>	<b>40</b>	<b>40</b>
<b>Max. Pressure Drop</b>	CONT.	[PSI]	[2900]	[2900]	[2900]	[2900]	[2320]	[2030]
		<b>MPA</b>	<b>20</b>	<b>20</b>	<b>20</b>	<b>18</b>	<b>16</b>	<b>14</b>
	INT.	[PSI]	[3480]	[3480]	[3480]	[3045]	[2610]	[2329]
		<b>MPA</b>	<b>24</b>	<b>24</b>	<b>24</b>	<b>21</b>	<b>18</b>	<b>16</b>
	PEAK	[PSI]	[4060]	[4060]	[4060]	[3480]	[3045]	[2610]
		<b>MPA</b>	<b>28</b>	<b>28</b>	<b>28</b>	<b>24</b>	<b>21</b>	<b>18</b>
<b>Max. Flow</b>	CONT.	[GPM]	[39.6]	[39.6]	[39.6]	[39.6]	[39.6]	[39.6]
		<b>L/MIN</b>	<b>150</b>	<b>150</b>	<b>150</b>	<b>150</b>	<b>150</b>	<b>150</b>
	INT.	[GPM]	[59.4]	[59.4]	[59.4]	[59.4]	[59.4]	[59.4]
		<b>L/MIN</b>	<b>225</b>	<b>225</b>	<b>225</b>	<b>225</b>	<b>225</b>	<b>225</b>
<b>Max. Inlet Pressure</b>	CONT.	[PSI]	[3045]	[3045]	[3045]	[3045]	[3045]	[3045]
		<b>MPA</b>	<b>21</b>	<b>21</b>	<b>21</b>	<b>21</b>	<b>21</b>	<b>21</b>
	INT.	[PSI]	[3625]	[3625]	[3625]	[3625]	[3625]	[3625]
		<b>MPA</b>	<b>25</b>	<b>25</b>	<b>25</b>	<b>25</b>	<b>25</b>	<b>25</b>
	PEAK	[PSI]	[4350]	[4350]	[4350]	[4350]	[4350]	[4350]
		<b>MPA</b>	<b>30</b>	<b>30</b>	<b>30</b>	<b>30</b>	<b>30</b>	<b>30</b>
<b>Weight</b>	[LB]	[70]	[72]	[74]	[77]	[80]	[84.6]	
	<b>KG</b>	<b>31.8</b>	<b>32.6</b>	<b>33.5</b>	<b>34.9</b>	<b>36.5</b>	<b>38.6</b>	

- \* Continuous pressure:
- \* Intermittent pressure:
- \* Peak pressure:

Max. value of operating motor continuously.  
 Max. value of operating motor in 6 seconds per minute.  
 Max. value of operating motor in 0.6 second per minute.

**YMV**



## Orbital Motors

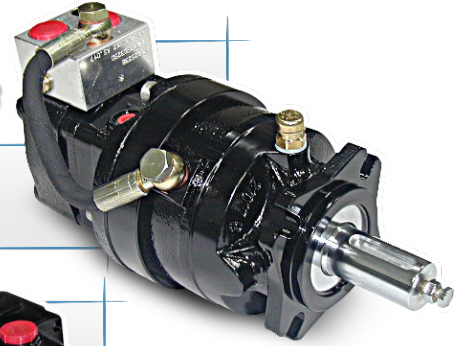

## High Speed Motors

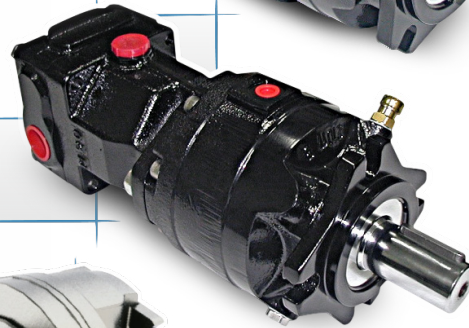

## Radial Piston Motors

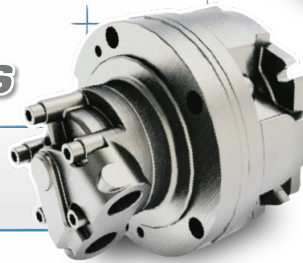

### TECHNICAL DATA

Brake Type	Static Torque [Lb-In]	Minimum Opening [Psi]	Maximum System [Psi]	Pilot Oil [Cu.In]
YBK2-200	1760	330	3000	0.6
YBK2-400	<b>3530</b>	<b>330</b>	<b>3000</b>	<b>0.6</b>
YBH-30	265 - 350	72	4350	0.6
YBH-70	<b>530 - 700</b>	<b>87</b>	<b>4350</b>	<b>0.6</b>
YBH-110	880 - 1060	145	4350	0.6
YBH-180	<b>1500 - 1680</b>	<b>190</b>	<b>4350</b>	<b>0.6</b>
YBH-240	2030 - 2200	190	4350	0.6
YBH-320	<b>2740 - 2900</b>	<b>245</b>	<b>4350</b>	<b>0.6</b>
YBH-420	3500 - 3900	245	4350	0.6
YBH-500	<b>4240 - 4600</b>	<b>275</b>	<b>4350</b>	<b>0.6</b>
YBS2-400	3500	360	4500	1
YBS2-650	<b>5750</b>	<b>595</b>	<b>4500</b>	<b>1</b>
YBS2-800	7050	365	4500	1
YBS2-1000	<b>8800</b>	<b>465</b>	<b>4500</b>	<b>1</b>
YBS2-1250	11.000	435	4500	1
YBS2-1500	<b>13.200</b>	<b>525</b>	<b>4500</b>	<b>1</b>
YBS2-1700	15.000	600	4500	1

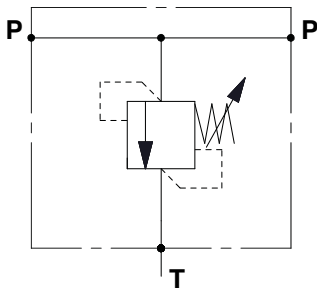

## *Single Cross-Port Relief Valve*

Port "A" or "B"  
With or Without Shuttle

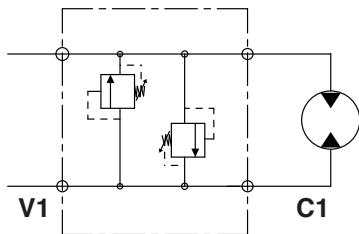

## *Dual Cross-Port Relief Valve*

With or Without Shuttle

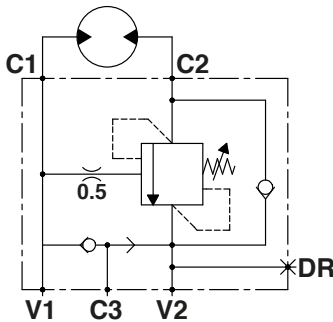

## *Single Counterbalance Valve*

Port "A" or "B"  
With or Without Shuttle

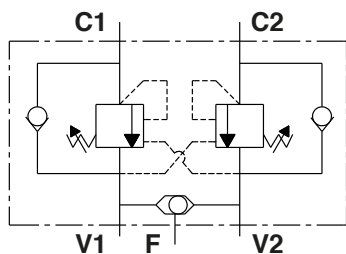

## *Dual Counterbalance Valve*

With or Without Shuttle

MANY OTHER VALVES AVAILABLE

## **BZZ SERIES Steering Valve**

The BZZ series has several different options.

- A) Open Center - Non Reaction
- B) Open Center - Reaction
- C) Closed Center - Non Reaction
- D) Load Sensing



## **10 SERIES Steering Valve**

The 10 series has several options and several variations.

### **CODE 101**

- A) Integral Pressure Control Valve
- B) Open Center- Non Reaction
- C) Open Center- Reaction



### **CODE 101-S With Integral Valves**

- A) Relief Valve
- B) Shock Valve
- C) Suction Valve
- D) Check Valve

### **CODE 101-5T Load Sensing System**

- A) Priority Valve
- B) Electro-Hydraulic Control Signal

### **CODE 103 Compact Valve**

- A) Open Center Non Reaction



### **CODE 103-S 103S-4 Open Center Non-Reaction**

- A) Relief valve
- B) Check valve

### **CODE 109 MINI STEERING UNIT, Open Center Non-Reaction**

- A) Relief Valve
- B) Relief And Check Valve
- C) Relief, Check And Shock Valve





## TLF - TLF 1 FLOW AMPLYIFIER STEERING UNIT

Used in place of Load sensing valve.



## BNF TORQUE AMPLYIFIER OPEN CENTER

This unit can transmit high torque output with low torque input.

A) Pressure relief valve



## FK SERIES VALVES

A variety of MANIFOLD valves that can be mounted directly on the steering valves for many functions.



## FLD FLOW DIVIDER VALVES

This series of valves is used to form a complete steering system in one unit.

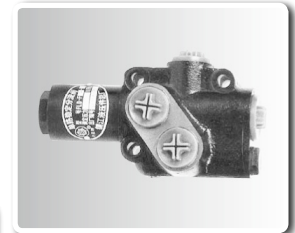

## DYXL PRIORITY VALVES

Used with the BZZ5 type load sensing valve or with the TLF1 Flow amplifying unit to form a load sensing power unit providing metered priority flow to the SCU.

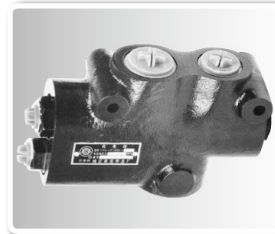

## PV PRIORITY VALVES

The PV (priority valve) is matched to the load sensing unit.

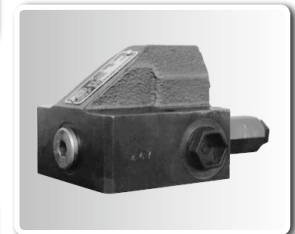

## LFF FLOW AMPLYFING VALVE

This valve uses small flow and low pressure to control large flow and high pressure. It can be used with the BZZ3 steering unit.

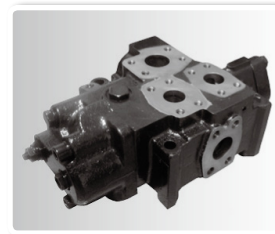

## LFA LFB FLOW AMPLYIFIER VALVES

With integral priority valve, directional valve, shock valve, and suction valve it can be used with 101-5TX series steering valve.

# Steering Columns

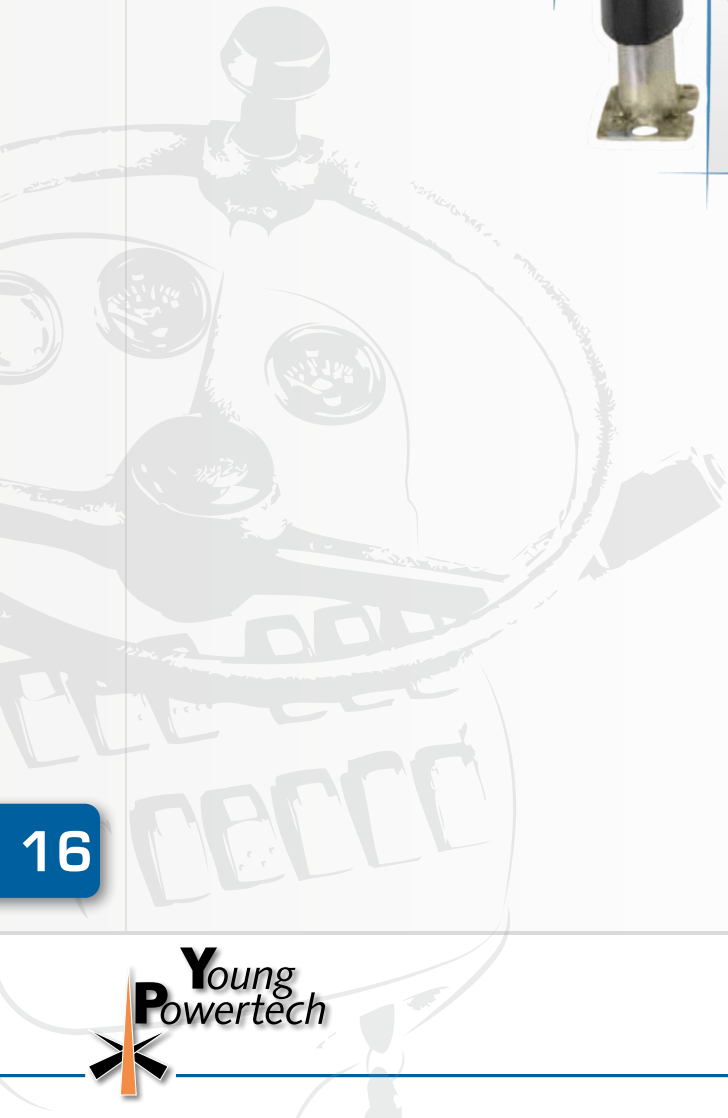



**PLUS**

## TECHNICAL SPECIFICATIONS

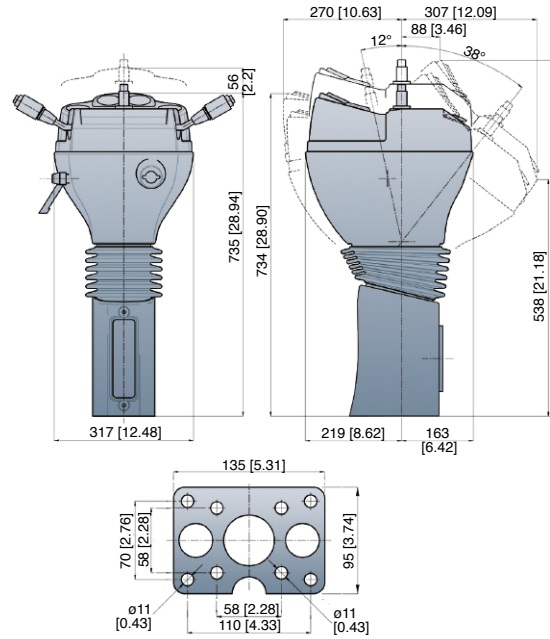

Steering column with 4 traditional instruments, 24 warnings LED lights and 12 switches. Available in different plastic colors: black, anthracite, light grey, light brown. Adjustable in horizontal and in vertical/horizontal positions.

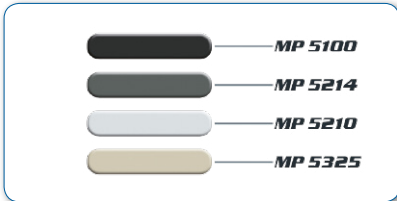

Steering column with 4 traditional instruments, loud speakers, 24 warnings LED lights and 12 switches.



**SOUND**

Steering column with 4 traditional instruments, radio, loud speakers, 24 warnings LED lights and 6 switches.



**AUDIO**

Steering column with 4 traditional instruments, 24 warnings LED lights and 6 switches.



**STANDARD**



## YSC SERIES

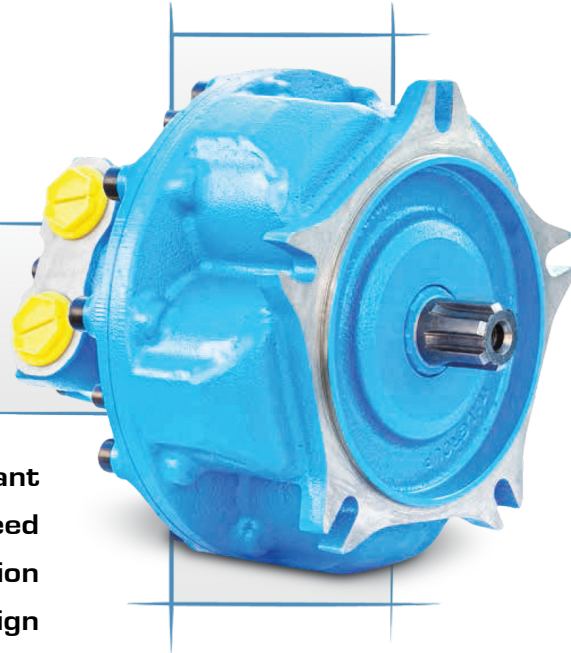

- Cavitation resistant**
- Freewheeling and high speed**
- Continuous operation**
- Compact design**
- Higher mechanical efficiency**
- Higher speed and power than standard series**

### INTRODUCTION

#### YSC series

The YSC radial "OSCILLATING PISTON CYLINDER" type motors have the most advanced design today on the market. This makes it possible to achieve HIGH SPEED, HIGHER PRESSURE and a higher ratio power/weight size. Heavier duty Tapered roller bearings will permit higher radial and axial loads and longer life.

After many years of research and testing combined with new design concept and production technologies, the results is a superior motor with excellent performance in terms of cavitation resistance, high speed, and freewheeling operation.

Available in 5 frames with displacements from 2.44 CIR to 112 CIR and with power capacity from 30 to 150 HP, this series of motors has been successful in all kinds of applications from Mobile to Industrial, Marine, Mining and other applications where HIGH TORQUE and low smooth speed is required.



## INSTALLATION DRAWING

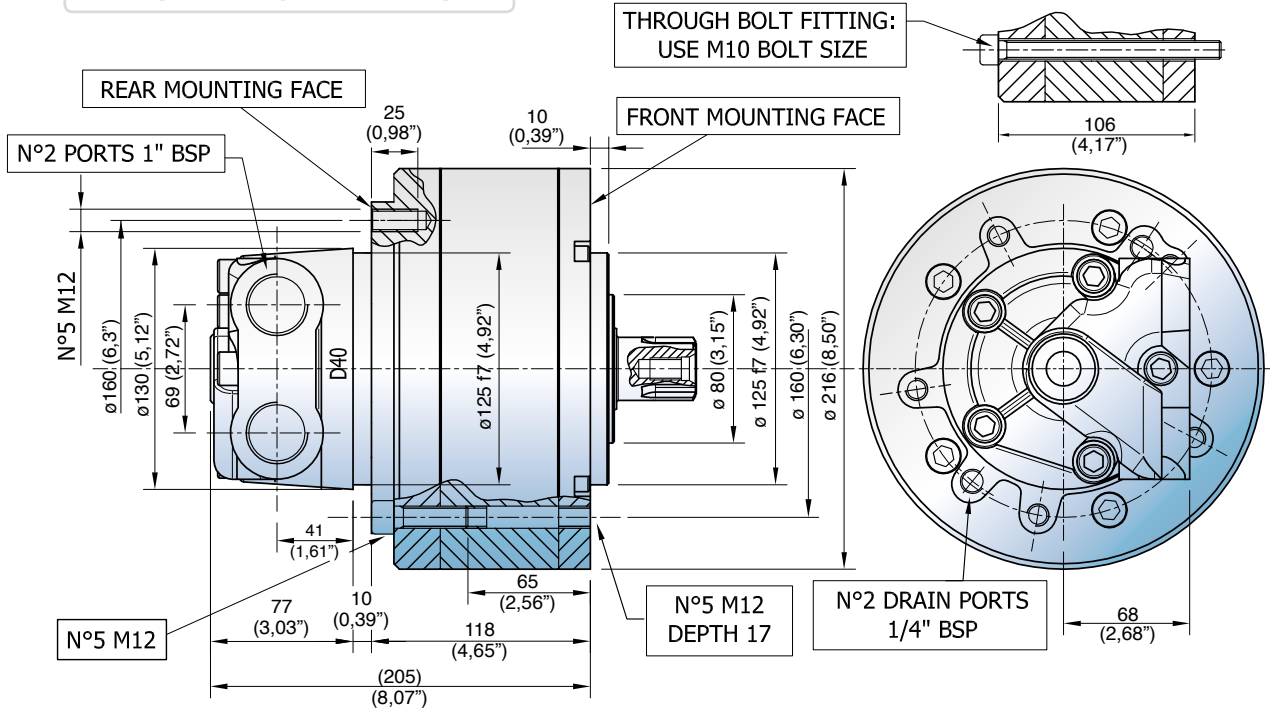

**YSC05**

TECHNICAL DATA

		40	60	75	90	110	130	150	170	200	250
Displacement	[cc]	40	60	74	91	115	129	150.7	166	191	226
	[cu.in.]	<b>2.44</b>	<b>3.66</b>	<b>4.52</b>	<b>5.55</b>	<b>7.02</b>	<b>7.87</b>	<b>9.20</b>	<b>10.13</b>	<b>11.66</b>	<b>13.79</b>
Specific Torque	[Nm/bar]	0.62	0.97	1.20	1.40	1.84	2.05	2.40	2.65	3.04	3.60
	[lb.ft/psi]	<b>0.03</b>	<b>0.05</b>	<b>0.06</b>	<b>0.07</b>	<b>0.09</b>	<b>0.10</b>	<b>0.12</b>	<b>0.14</b>	<b>0.16</b>	<b>0.18</b>
Max. Cont. Pressure	[bar]	250	250	250	250	250	250	250	250	250	250
	[psi]	<b>3625</b>	<b>3625</b>	<b>3625</b>	<b>3625</b>	<b>3625</b>	<b>3625</b>	<b>3625</b>	<b>3625</b>	<b>3625</b>	<b>3625</b>
Max. Int. Pressure	[bar]	320	320	320	320	320	320	320	320	320	320
	[psi]	<b>4600</b>	<b>4600</b>	<b>4600</b>	<b>4600</b>	<b>4600</b>	<b>4600</b>	<b>4600</b>	<b>4600</b>	<b>4600</b>	<b>4600</b>
Peak Pressure	[bar]	350	350	350	350	350	350	350	350	350	350
	[psi]	<b>5050</b>	<b>5050</b>	<b>5050</b>	<b>5050</b>	<b>5050</b>	<b>5050</b>	<b>5050</b>	<b>5050</b>	<b>5050</b>	<b>5050</b>
Max. Cont. Speed	[rpm]	1200	1200	1200	1000	850	850	850	750	750	600
Peak Speed (**)	[rpm]	1400	1400	1400	1300	1100	1100	1100	1000	1000	800
Max. Cont. Power (***)	[kW]	22	22	35	35	35	35	35	35	35	35
	[hp]	<b>30</b>	<b>30</b>	<b>47</b>	<b>47</b>	<b>47</b>	<b>47</b>	<b>47</b>	<b>47</b>	<b>47</b>	<b>47</b>
Peak Power (****)	[kW]	35	35	55	55	55	55	55	55	55	55
	[hp]	<b>46.935</b>	<b>46.935</b>	<b>73.755</b>	<b>73.755</b>	<b>73.755</b>	<b>73.755</b>	<b>73.755</b>	<b>73.755</b>	<b>73.755</b>	<b>73.755</b>
Max. Case Pressure	[bar]	6	6	6	6	6	6	6	6	6	6
	[psi]	<b>87</b>	<b>87</b>	<b>87</b>	<b>87</b>	<b>87</b>	<b>87</b>	<b>87</b>	<b>87</b>	<b>87</b>	<b>87</b>
Dry Weight	[kg]	30	30	30	30	30	30	30	30	30	30
	[lbs]	<b>66</b>	<b>66</b>	<b>66</b>	<b>66</b>	<b>66</b>	<b>66</b>	<b>66</b>	<b>66</b>	<b>66</b>	<b>66</b>
Temperature Range (*)	[°C]	-30÷70	-30÷70	-30÷70	-30÷70	-30÷70	-30÷70	-30÷70	-30÷70	-30÷70	-30÷70
	[°F]	<b>-86÷160</b>	<b>-86÷160</b>	<b>-86÷160</b>	<b>-86÷160</b>	<b>-86÷160</b>	<b>-86÷160</b>	<b>-86÷160</b>	<b>-86÷160</b>	<b>-86÷160</b>	<b>-86÷160</b>

(\*) Please refer to the "Hydraulic fluid recommendations"  
 (\*\*\*) Do not exceed maximum power  
 (\*\*\*\*) For motor operation with a continuous duty cycle at maximum continuous power the motor flushing is required  
 (\*\*\*\*\*) For motor operation at peak power flushing is usually required. For more information please contact our technical department

# Radial Piston Motors

## INSTALLATION DRAWING



YSC1

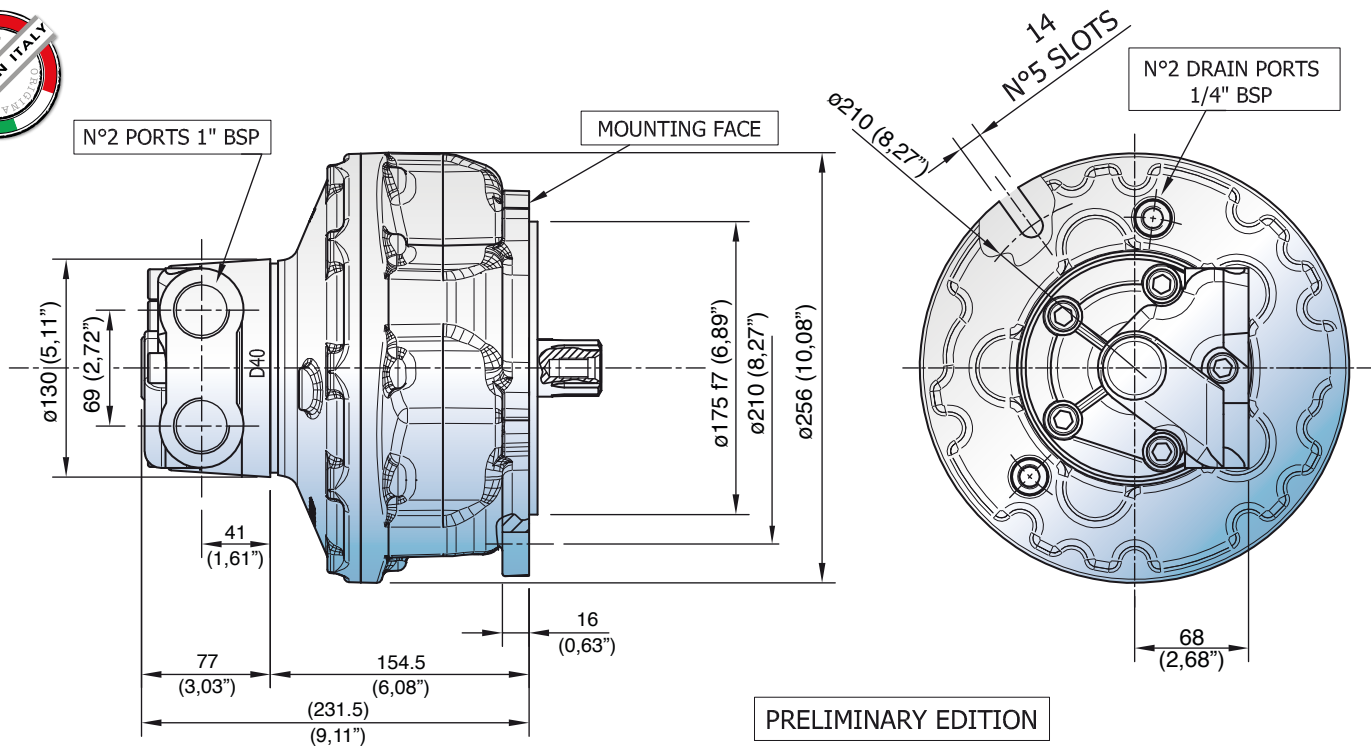

PRELIMINARY EDITION

TECHNICAL DATA

		100	150	175	200	250	300	350
Displacement	[cc]	98	154	173	200	243	289	315
	[cu.in.]	<b>5.98</b>	<b>9.40</b>	<b>10.56</b>	<b>12.20</b>	<b>14.83</b>	<b>17.64</b>	<b>19.22</b>
Specific Torque	[Nm/bar]	1.57	2.45	2.74	3.20	3.88	4.61	5.01
	[lb.ft/psi]	<b>0.08</b>	<b>0.13</b>	<b>0.14</b>	<b>0.16</b>	<b>0.20</b>	<b>0.24</b>	<b>0.26</b>
Max. Cont. Pressure	[bar]	250	250	250	250	250	250	250
	[psi]	<b>3625</b>	<b>3625</b>	<b>3625</b>	<b>3625</b>	<b>3625</b>	<b>3625</b>	<b>3625</b>
Max. Int. Pressure	[bar]	320	320	320	320	320	320	320
	[psi]	<b>4600</b>	<b>4600</b>	<b>4600</b>	<b>4600</b>	<b>4600</b>	<b>4600</b>	<b>4600</b>
Peak Pressure	[bar]	350	350	350	350	350	350	350
	[psi]	<b>5050</b>	<b>5050</b>	<b>5050</b>	<b>5050</b>	<b>5050</b>	<b>5050</b>	<b>5050</b>
Max. Cont. Speed	[rpm]	1000	700	700	600	600	500	400
Peak Speed (**)	[rpm]	<b>1200</b>	<b>900</b>	<b>900</b>	<b>800</b>	<b>800</b>	<b>700</b>	<b>650</b>
Max. Cont. Power (***)	[kW]	40	40	40	40	40	40	40
	[hp]	<b>54</b>	<b>54</b>	<b>54</b>	<b>54</b>	<b>54</b>	<b>54</b>	<b>54</b>
Peak Power (****)	[kW]	60	60	60	60	60	60	60
	[hp]	<b>80</b>	<b>80</b>	<b>80</b>	<b>80</b>	<b>80</b>	<b>80</b>	<b>80</b>
Max. Case Pressure	[bar]	6	6	6	6	6	6	6
	[psi]	<b>87</b>	<b>87</b>	<b>87</b>	<b>87</b>	<b>87</b>	<b>87</b>	<b>87</b>
Dry Weight	[kg]	34	34	34	34	34	34	34
	[lbs]	<b>75</b>	<b>75</b>	<b>75</b>	<b>75</b>	<b>75</b>	<b>75</b>	<b>75</b>
Temperature Range (*)	[°C]	-30÷70	-30÷70	-30÷70	-30÷70	-30÷70	-30÷70	-30÷70
	[°F]	<b>-86÷160</b>	<b>-86÷160</b>	<b>-86÷160</b>	<b>-86÷160</b>	<b>-86÷160</b>	<b>-86÷160</b>	<b>-86÷160</b>

(\*) Please refer to the "Hydraulic fluid recommendations"  
 (\*\*) Do not exceed maximum power  
 (\*\*\*) For motor operation with a continuous duty cycle at maximum continuous power the motor flushing is required  
 (\*\*\*\*) For motor operation at peak power flushing is usually required. For more information please contact our technical department



# Radial Piston Motors

## INSTALLATION DRAWING



YSC3

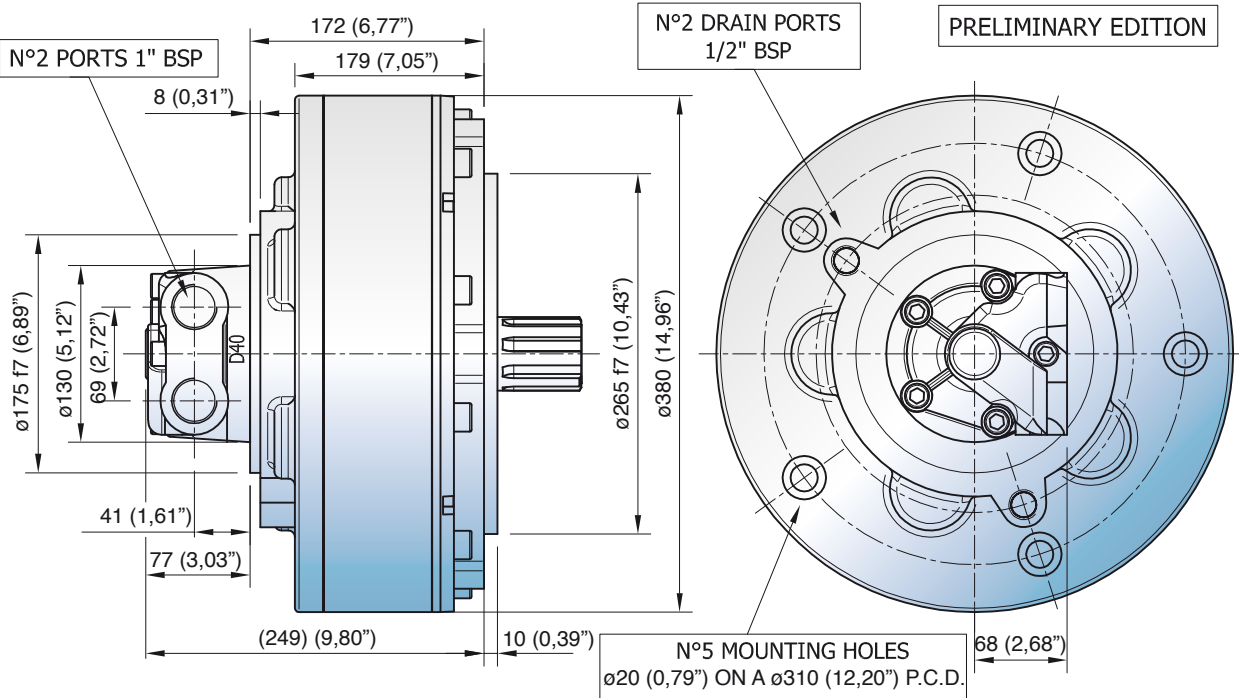

TECHNICAL DATA

		350	400	500	600	700	800	900	1000
Displacement	[cc]	352	426	486	595	689	792	872	988
	[cu.in.]	<b>21.48</b>	<b>26.00</b>	<b>29.66</b>	<b>36.31</b>	<b>42.05</b>	<b>48.33</b>	<b>53.21</b>	<b>60.29</b>
Specific Torque	[Nm/bar]	5.60	6.78	7.73	9.47	10.98	12.60	13.90	15.70
	[lb.ft/psi]	<b>0.29</b>	<b>0.35</b>	<b>0.40</b>	<b>0.48</b>	<b>0.56</b>	<b>0.64</b>	<b>0.71</b>	<b>0.80</b>
Max. Cont. Pressure	[bar]	250	250	250	250	250	250	250	250
	[psi]	<b>3625</b>	<b>3625</b>	<b>3625</b>	<b>3625</b>	<b>3625</b>	<b>3625</b>	<b>3625</b>	<b>3625</b>
Max. Int. Pressure	[bar]	320	320	320	320	320	320	320	320
	[psi]	<b>4600</b>	<b>4600</b>	<b>4600</b>	<b>4600</b>	<b>4600</b>	<b>4600</b>	<b>4600</b>	<b>4600</b>
Peak Pressure	[bar]	350	350	350	350	350	350	350	350
	[psi]	<b>5050</b>	<b>5050</b>	<b>5050</b>	<b>5050</b>	<b>5050</b>	<b>5050</b>	<b>5050</b>	<b>5050</b>
Max. Cont. Speed	[rpm]	600	600	500	400	400	350	325	300
Peak Speed (**)	[rpm]	800	800	700	600	600	550	525	500
Max. Cont. Power (***)	[kW]	66	66	66	66	66	66	66	66
	[hp]	<b>89</b>	<b>89</b>	<b>89</b>	<b>89</b>	<b>89</b>	<b>89</b>	<b>89</b>	<b>89</b>
Peak Power (****)	[kW]	84	84	84	84	84	84	84	84
	[hp]	<b>113</b>	<b>113</b>	<b>113</b>	<b>113</b>	<b>113</b>	<b>113</b>	<b>113</b>	<b>113</b>
Max. Case Pressure	[bar]	6	6	6	6	6	6	6	6
	[psi]	<b>87</b>	<b>87</b>	<b>87</b>	<b>87</b>	<b>87</b>	<b>87</b>	<b>87</b>	<b>87</b>
Dry Weight	[kg]	92	92	92	92	92	92	92	92
	[lbs]	<b>203</b>	<b>203</b>	<b>203</b>	<b>203</b>	<b>203</b>	<b>203</b>	<b>203</b>	<b>203</b>
Temperature Range (*)	[°C]	-30÷70	-30÷70	-30÷70	-30÷70	-30÷70	-30÷70	-30÷70	-30÷70
	[°F]	<b>-86÷160</b>	<b>-86÷160</b>	<b>-86÷160</b>	<b>-86÷160</b>	<b>-86÷160</b>	<b>-86÷160</b>	<b>-86÷160</b>	<b>-86÷160</b>

(\*) Please refer to the "Hydraulic fluid recommendations"  
 (\*\*) Do not exceed maximum power  
 (\*\*\*) For motor operation with a continuous duty cycle at maximum continuous power the motor flushing is required  
 (\*\*\*\*) For motor operation at peak power flushing is usually required. For more information please contact our technical department

## INSTALLATION DRAWING

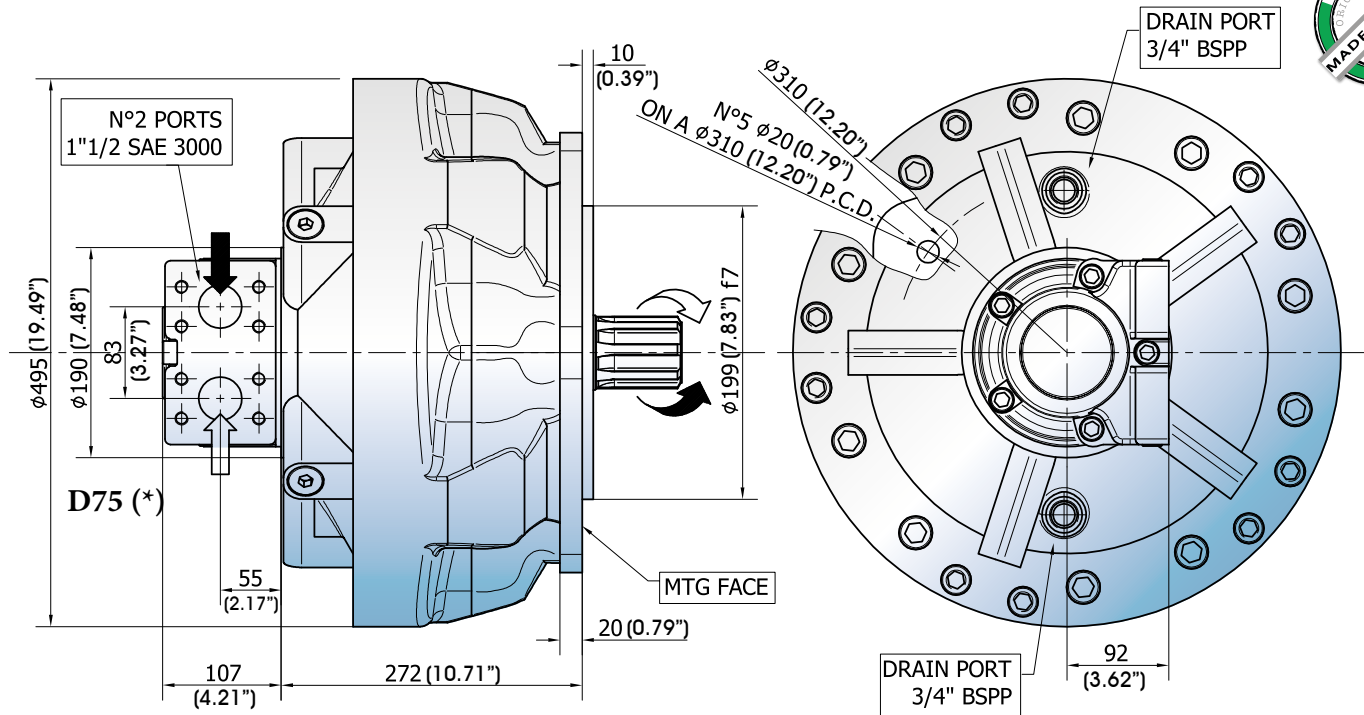

YSC5

TECHNICAL DATA

		800	1000	1200	1300	1500	1600	1800	2000
Displacement	[cc]	808	1040	1190	1340	1464	1635	1816	2010
	[cu.in.]	49.3	63.4	72.6	81.7	89.3	99.7	110.8	122.6
Specific Torque	[Nm/bar]	12.6	16.2	18.5	20.9	22.8	25.4	28.3	31.3
	[lb.ft/psi]	0.64	0.83	0.94	1.06	1.16	1.29	1.44	1.59
Max. Cont. Pressure	[bar]	250	250	250	250	250	250	250	250
	[psi]	3625	3625	3625	3625	3625	3625	3625	3625
Max. Int. Pressure	[bar]	320	320	320	320	320	320	320	320
	[psi]	4600	4600	4600	4600	4600	4600	4600	4600
Peak Pressure	[bar]	350	350	350	350	350	350	350	350
	[psi]	5050	5050	5050	5050	5050	5050	5050	5050
Max. Cont. Speed	[rpm]	350	320	320	320	300	280	280	220
Peak Speed (***)	[rpm]	470	470	430	430	380	350	350	280
Max. Cont. Power (****)	[kW]	100	100	100	100	100	100	100	100
	[hp]	134	134	134	134	134	134	134	134
Peak Power (*****)	[kW]	150	150	150	150	150	150	150	150
	[hp]	201	201	201	201	201	201	201	201
Max. Case Pressure	[bar]	6	6	6	6	6	6	6	6
	[psi]	87	87	87	87	87	87	87	87
Dry Weight	[kg]	178	178	178	178	178	178	178	178
	[lbs]	392	392	392	392	392	392	392	392
Temperature Range (**)	[°C]	-30÷70	-30÷70	-30÷70	-30÷70	-30÷70	-30÷70	-30÷70	-30÷70
	[°F]	-86÷160	-86÷160	-86÷160	-86÷160	-86÷160	-86÷160	-86÷160	-86÷160

(\*) The standard distributor (D75) is shown. Please refer to distributors section for different distributor interfaces.  
 (\*\*) Please refer to the "Hydraulic fluid recommendations"  
 (\*\*\*) Do not exceed maximum power  
 (\*\*\*\*) For motor operation with a continuous duty cycle at maximum continuous power the motor flushing is required  
 (\*\*\*\*\*) For motor operation at peak power flushing is usually required. For more information please contact our technical department



# Radial Piston Motors



## SAE OUTPUT

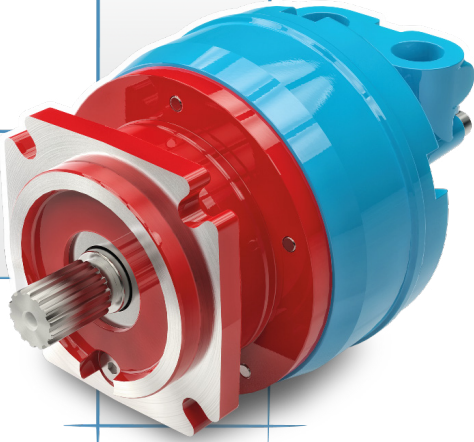

**YSC-05-SAE "C"**

4 Bolts 12/24 DP-14 T Shaft

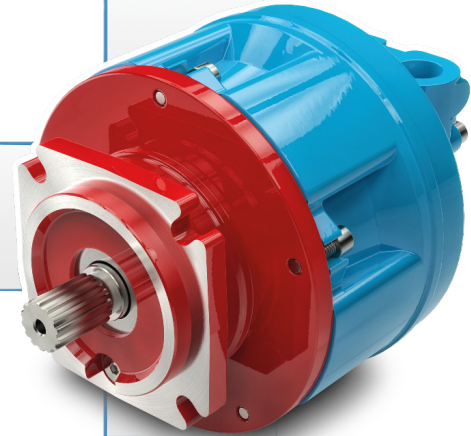

**YSC-1-SAE "C"**

4 Bolts 12/24 DP-14 T Shaft



**YSC-2-SAE "D"**

4 Bolts 8/16 DP-13 T Shaft

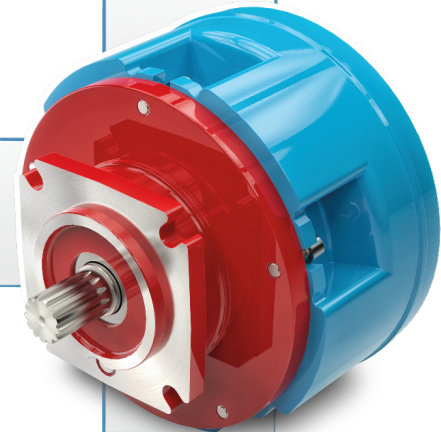

**YSC-3-SAE "D"**

4 Bolts 8/16 DP-13 T Shaft



## G 20-27-34

## G 50-75-90-100

## GD 100

**SERIES**

**SINGLE & DUAL DISPLACEMENT**

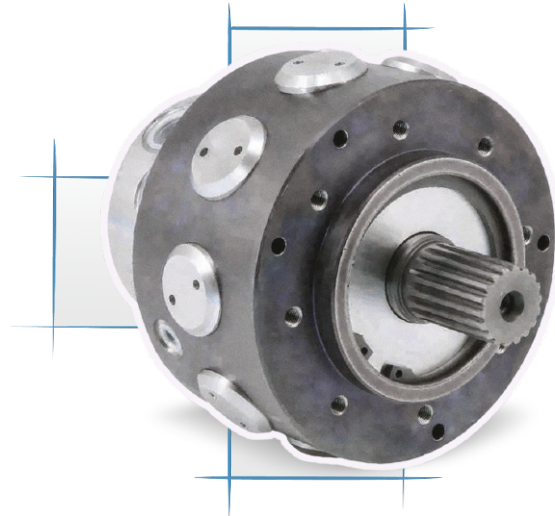

### TECHNICAL DATA

#### SINGLE DISPLACEMENT MOTOR

Model	G20	G27	G34	G50	G75	G90	G100
Displacement [cc/Rev]	20,5	27,3	34,2	50,9	76,3	89	102
Specific Theoretical Torque [Nm/bar]	0.32	0.43	0.54	0.81	1.21	1.41	1.61
Maximum Speed [rpm]	2500	2500	2500	2400	2300	2200	2200
Minimum Speed [rpm]	40	35	30	25	20	15	10
Mechanical Efficiency [%]	84	87	88,5	88	89	89.2	89.5
Starting Mechanical Efficiency [%]	78	84	85,8	80	85	86	87
Continuous Maximum Power [kW]	10	14	17	25	35	42	48
Maximum Power [kW]	12	17	21	31	44	52	60
Continuous Maximum Pressure [bar]	250	250	250	250	250	250	250
Intermittent Maximum Pressure [bar]	280	280	280	280	280	280	280
Peak Pressure [bar]	350	350	350	350	350	350	350
Dry Weight	19	19	19	25	25	25	25
Recommended Flushing Flow [l/min]	3	3	3	3	5	5	5

#### DUAL DISPLACEMENT MOTOR

Model	G20	G27	G34	G50	G75
Max Displacement [cc/Rev]	20,5	27,3	34,2	50,9	76,3
Specific Theoretical Torque [Nm/bar]	0.32	0.43	0.54	0.81	1.21
Maximum Speed [rpm]	2500	2500	2500	2400	2300
Minimum Speed [rpm]	40	35	30	25	20
Mechanical Efficiency [%]	84	87	88,5	88	89
Starting Mechanical Efficiency [%]	78	84	85,8	80	85
Continuous Maximum Power [kW]	10	14	17	25	35
Maximum Power [kW]	12	17	21	31	44
Continuous Maximum Pressure [bar]	250	250	250	250	250
Intermittent Maximum Pressure [bar]	280	280	280	280	280
Peak Pressure [bar]	350	350	350	350	350
Dry Weight	19	19	19	25	25
Recommended Flushing Flow [l/min]	3	3	3	3	5

G series

GD series

25



## YIAM SERIES

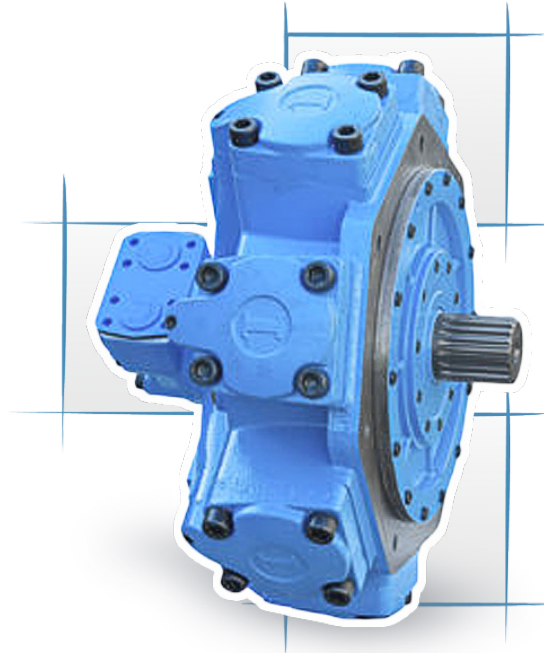

### INTRODUCTION

#### YIAM series

YIAM series motor range varies from 20cc to 8500cc displacement and it is completed by two-speed motors and special motors created in cooperation with our clients for different applications such as : underwater, high & low speed and wheel motors and with the possibility to assemble valves, brakes or gear reductions.

New bearing construction to prevent from seizure of the connecting rod with the external bushing. This could happen in high speed and high pressure working conditions and could lead to motor breakdown.

The new bearing design consists of:

**spacers, with function of**

- keeping roller axis parallel
- creating space between rollers to hold more oil

**spacer rings, with function of**

- keeping rollers lined up
- absorbing axial forces coming from connection rod

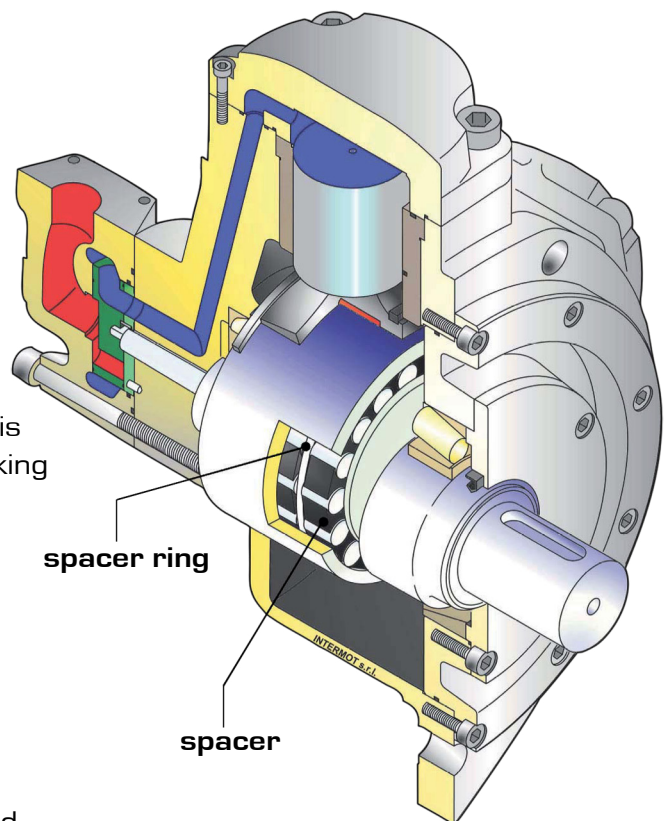

# Radial Piston Motors

## TECHNICAL DATA



MODEL		Displacement	Specific Torque	Pressure			Speed		Max Case Pressure	Max Power		Dry Weight	Inertia moment of rotating parts		
				Max Cont.	Max Int.	Peak	Max Cont.	Peak		hp	kW				
				cc/rev	Nm/bar	bar	bar	bar		rpm	rpm			bar	kg
YIAM 80	H1	5	80	1.3	250	300	350	950	1050	6	54	40	26	18	
YIAM 100		5	100	1.6	250	300	350	950	1050	6	54	40	26	18	
YIAM 150		5	157	2.5	250	300	350	950	1050	6	54	40	26	18	
YIAM 175		5	176	2.8	250	300	350	800	900	6	54	40	26	18	
YIAM 195		5	195	3.1	250	300	350	800	900	6	54	40	26	18	
YIAM 200		5	207	3.3	250	300	350	750	850	6	54	40	26	18	
YIAM 250		5	257	4.1	250	300	350	750	850	6	54	40	26	18	
YIAM 300		5	307	4.9	250	300	350	750	850	6	54	40	26	18	
YIAM 200	H2	5	198	3.2	250	300	350	800	900	6	66	49	42	27	
YIAM 250		5	253	4.0	250	300	350	750	850	6	66	49	42	27	
YIAM 300		5	314	5.0	250	300	350	750	850	6	66	49	42	27	
YIAM 350		5	362	5.8	250	300	350	650	750	6	66	49	42	27	
YIAM 400		5	424	6.7	250	300	350	600	700	6	66	49	42	27	
YIAM 500		5	492	7.8	250	300	350	500	600	6	66	49	42	27	
YIAM 600		5	584	9.3	250	300	350	500	600	6	66	49	42	27	
YIAM 350		H3	5	349	5.6	250	300	350	630	700	6	91	68	68	214
YIAM 300	5		397	6.3	250	300	350	600	680	6	91	68	68	214	
YIAM 450	5		452	7.2	250	300	350	600	680	6	91	68	68	214	
YIAM 500	5		491	7.8	250	300	350	600	680	6	91	68	68	214	
YIAM 600	5		594	9.4	250	300	350	550	630	6	91	68	68	214	
YIAM 650	5		660	10.5	250	300	350	500	580	6	91	68	68	214	
YIAM 700	5		707	11.2	250	300	350	450	500	6	91	68	68	214	
YIAM 800	5		791	12.6	250	300	350	400	450	6	91	68	68	214	
YIAM 700	H4	5	714	11.4	250	300	350	500	580	6	107	80	92	267	
YIAM 800		5	792	12.6	250	300	350	450	530	6	107	80	92	267	
YIAM 850		5	847	13.5	250	300	350	450	530	6	107	80	92	267	
YIAM 900		5	904	14.4	250	300	350	450	530	6	107	80	92	267	
YIAM 1000		5	992	15.8	250	300	350	330	400	6	107	80	92	267	
YIAM 1100		5	1116	17.8	250	300	350	330	400	6	107	80	92	267	
YIAM 1200		5	1192	19.0	250	300	350	300	350	6	107	80	92	267	
YIAM 1250		5	1247	19.8	250	300	350	250	300	6	107	80	92	267	
YIAM 1400	H45	5	1332	21.2	250	300	350	230	280	6	107	80	92	267	
YIAM 1100		5	1183	18.8	250	300	350	350	400	6	161	120	118	380	
YIAM 1400		5	1376	21.9	250	300	350	300	350	6	161	120	118	380	
YIAM 1600		5	1648	26.2	250	300	350	275	325	6	161	120	118	380	
YIAM 1800		5	1815	28.9	250	300	350	250	300	6	161	120	118	380	
YIAM 1000		H5	5	1094	17.4	250	300	350	350	400	6	161	120	173	697
YIAM 1200			5	1231	19.6	250	300	350	300	350	6	161	120	173	697
YIAM 1400			5	1376	21.9	250	300	350	300	350	6	161	120	173	697
YIAM 1500	5		1528	24.3	250	300	350	300	350	6	161	120	173	697	
YIAM 1600	5		1648	26.2	250	300	350	300	340	6	161	120	173	697	
YIAM 1800	5		1815	28.9	250	300	350	250	300	6	161	120	173	697	
YIAM 2000	5		2035	32.4	250	300	350	230	260	6	161	120	173	697	
YIAM 2200	5		2220	35.3	250	300	350	220	240	6	161	120	173	697	
YIAM 2200	H55	5	2126	33.8	250	300	350	240	280	6	228	170	173	837	
YIAM 2500		5	2525	40.2	250	300	350	240	280	6	228	170	173	837	
YIAM 2800		5	2807	44.7	250	300	350	240	280	6	228	170	173	837	
YIAM 3000		5	3028	48.2	250	300	350	230	270	6	228	170	173	837	
YIAM 2200		H6	5	2206	35.1	250	300	350	220	260	6	228	170	308	1745
YIAM 2500			5	2525	40.2	250	300	350	220	260	6	228	170	308	1745
YIAM 2800			5	2807	44.7	250	300	350	220	260	6	228	170	308	1745
YIAM 3000			5	2983	47.5	250	300	350	210	250	6	228	170	308	1745
YIAM 3200	5		3289	52.3	250	300	350	200	240	6	228	170	308	1745	
YIAM 3500	5		3479	55.4	250	300	350	200	240	6	228	170	308	1745	
YIAM 3900	H7		7	3907	62.2	250	300	350	160	200	6	241	180	405	4064
YIAM 4300			7	4343	69.1	250	300	350	150	190	6	241	180	405	4064
YIAM 4600		7	4616	73.5	250	300	350	140	190	6	241	180	405	4064	
YIAM 5000		7	5088	81.0	250	300	350	140	180	6	241	180	405	4064	
YIAM 5400		7	5384	85.7	250	300	350	130	170	6	241	180	405	4064	
YIAM 6000		H8	10	5966	95.0	250	290	320	120	140	6	255	190	590	5380
YIAM 6500			10	6581	104.7	250	290	320	120	140	6	255	190	590	5380
YIAM 6800			10	6962	110.8	250	290	320	120	140	6	255	190	590	5380
YIAM 7600	10		7620	121.3	190	230	280	90	100	6	241	180	590	5380	
YIAM 8000	10	8062	128.3	180	220	270	80	90	6	241	180	590	5380		

YIAM series



## YIAC SERIES DUAL DISPLACEMENT

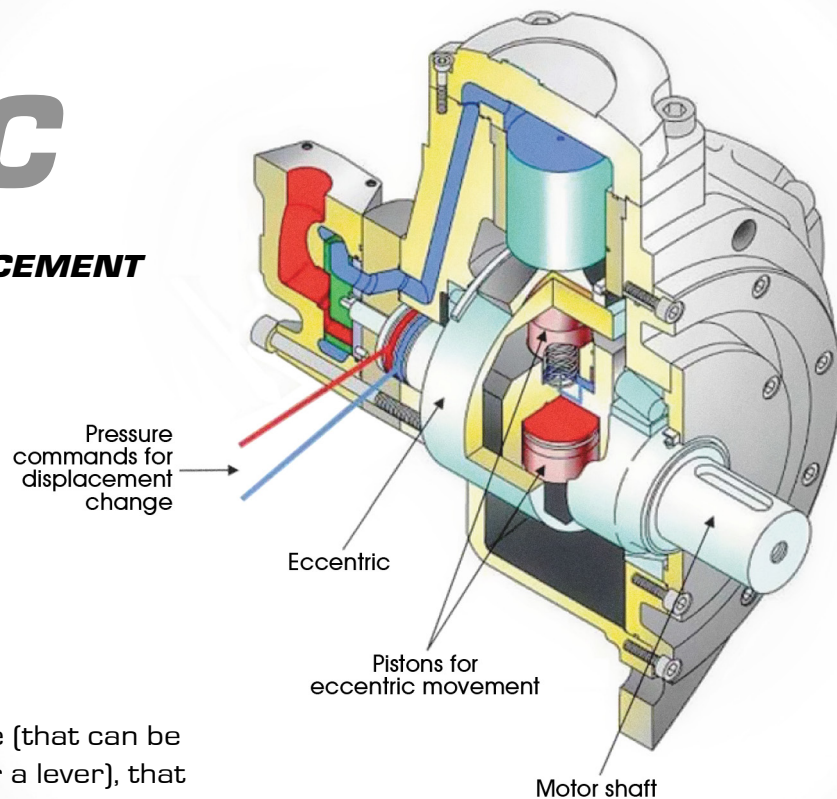

### Working explanation

There is an external valve (that can be activated by a solenoid or a lever), that is responsible for the pressure change in the pressure commands. The pressure commands act on the two pistons inside the eccentric; the pistons move and therefore pull the eccentric, that cause the pistons stroke variation and, therefore the displacement change. In this manner we can have two displacements in the same motor.

### GENERAL INFORMATION

#### YIAC series

Young Powertech Inc. produces RADIAL PISTON HYDRAULIC MOTORS since 1985: our yearly production is more than 13.000 units which we sell all over the world through our agents and authorized sellers. Our motor range varies from 20cc to 8500cc displacement and it is completed by two-speed motors and special motors created in cooperation with our clients for different applications such as : underwater, high & low speed and wheel motors and with the possibility to assemble valves, brakes or gear reductions. You can directly contact our Technical Department which will give you all the necessary support to find the right solutions to your problems.

Young Powertech Inc. is a flexible work reality and manages deliveries within the same day of order; we produce motors exactly interchangeable with our competitors, always ready in stock which our customers particularly appreciate.



## TECHNICAL DATA

Displacement [cc/Rev]	195	175	150	125	100	95	75	69
Specific Theoretical Torque [Nm/bar]	3.1	2.8	2.4	2	1.6	1.5	1.2	1.1
Continuous Maximum Speed [rpm]	750	750	750	775	775	775	800	850
Minimum Speed [rpm]	3	3	3	4	4	4	5	5
Mechanical Efficiency [%]	89.5	89.2	89	88.5	88	87.8	87	85.5
Starting Mechanical Efficiency [%]	84.5	84.2	85	84.5	84	83	81	78
Continuous Maximum Power [kW]	36	34	32	30	28	28	26	24
Intermittent Maximum Power [kW]	45	42.5	40	37.5	35	35	32.5	30
Continuous Maximum Pressure [bar]	250	250	250	250	250	250	250	250
Intermittent Maximum Pressure [bar]	275	275	275	275	275	275	275	275
Peak Pressure [bar]	350	350	350	350	350	350	350	350
Recommended Flushing Flow [l/min]	8	8	8	8	8	8	8	8

Displacement [cc/Rev]	257	232	195	175	150	125	100	95
Specific Theoretical Torque [Nm/bar]	4.1	3.7	3.1	2.8	2.4	2	1.6	1.5
Continuous Maximum Speed [rpm]	700	700	750	750	750	775	775	775
Minimum Speed [rpm]	3	3	3	3	3	4	4	5
Mechanical Efficiency [%]	88.5	88.2	88	87.5	87	86.8	86	84.5
Starting Mechanical Efficiency [%]	83.5	83.2	84	83.5	83	82	80	77
Continuous Maximum Power [kW]	38	37	36	34	32	30	28	28
Intermittent Maximum Power [kW]	47.5	46	45	42.5	40	37.5	35	35
Continuous Maximum Pressure [bar]	250	250	250	250	250	250	250	250
Intermittent Maximum Pressure [bar]	275	275	275	275	275	275	275	275
Peak Pressure [bar]	350	350	350	350	350	350	350	350
Recommended Flushing Flow [l/min]	10	10	10	10	10	10	10	10

Displacement [cc/Rev]	492	442	393	344	292	255	197	147	98
Specific Theoretical Torque [Nm/bar]	7.8	7	6.3	5.5	4.7	4.1	3.1	2.3	1.6
Continuous Maximum Speed [rpm]	450	505	520	545	580	595	600	600	600
Minimum Speed [rpm]	2	2	2	2	2	3	3	3	4
Mechanical Efficiency [%]	87.5	86	85	83.6	82.4	82	80	78	73.4
Starting Mechanical Efficiency [%]	82.5	81	80	77.2	74.3	69.6	62.1	52	30
Continuous Maximum Power [kW]	61	60	57	50	44	36	26	20	9
Intermittent Maximum Power [kW]	66	75	71	62.5	55	45	21	25	11
Continuous Maximum Pressure [bar]	250	250	250	250	250	250	250	250	250
Intermittent Maximum Pressure [bar]	275	275	275	275	275	275	275	275	275
Peak Pressure [bar]	350	350	350	350	350	350	350	350	350
Recommended Flushing Flow [l/min]	10	10	10	10	10	10	10	10	10

Displacement [cc/Rev]	792	660	575	493	410	328	273	245	245
Specific Theoretical Torque [Nm/bar]	12.6	10.5	9.2	7.8	6.5	5.2	4.3	3.9	2.6
Continuous Maximum Speed [rpm]	450	540	600	600	600	600	600	600	600
Minimum Speed [rpm]	2	2	2	2	2	2	2	3	3
Mechanical Efficiency [%]	90.8	90.4	88.5	88	87.4	84.5	82.4	82	60.2
Starting Mechanical Efficiency [%]	84.8	84.4	82.6	79	75	70.2	68.3	60.8	43.3
Continuous Maximum Power [kW]	100	90	80	68	53	43	38	30	15
Intermittent Maximum Power [kW]	120	108	96	82	64	52	46	36	18
Continuous Maximum Pressure [bar]	250	250	250	250	250	250	250	250	250
Intermittent Maximum Pressure [bar]	275	275	275	275	275	275	275	275	275
Peak Pressure [bar]	350	350	350	350	350	350	350	350	350
Recommended Flushing Flow [l/min]	10	10	10	10	10	10	10	10	10

YIAC 250 H1

YIAC 800 H4

YIAC 195 H1



YIAC 500 H3

## TECHNICAL DATA

YIAC 1400 H5



YIAC 3000 H6

Displacement [cc/Rev]	1600	1499	1393	1313	1235	1150	1070	980	900	820
Specific Theoretical Torque [Nm/bar]	25.5	23.9	22.2	20.9	19.7	18.3	17	15.6	14.3	13
Continuous Maximum Speed [rpm]	370	400	410	435	440	460	480	490	495	520
Minimum Speed [rpm]	1	1	1	1	1	1	1	1	1	2
Mechanical Efficiency [%]	94.2	94	93.9	93.7	93.5	93.4	93.2	93	92.6	92.3
Starting Mechanical Efficiency [%]	88.2	88	86,5	85,3	85.1	82.6	81.3	79.8	77.9	76
Continuous Maximum Power [kW]	139	138	135	128	127	124	119	115	110	105
Intermittent Maximum Power [kW]	171	170	166	158	157	153	147	142	136	130
Continuous Maximum Pressure [bar]	250	250	250	250	250	250	250	250	250	250
Intermittent Maximum Pressure [bar]	275	275	275	275	275	275	275	275	275	275
Peak Pressure [bar]	350	350	350	350	350	350	350	350	350	350
Recommended Flushing Flow [l/min]	12	12	12	12	12	12	12	12	12	12

Displacement [cc/Rev]	737	655	574	492	410	328	246	164	82
Specific Theoretical Torque [Nm/bar]	11.7	10.4	9.1	7.8	6.5	5.2	3.9	2.6	1.3
Continuous Maximum Speed [rpm]	545	600	600	600	600	600	600	600	1000
Minimum Speed [rpm]	2	2	2	2	2	3	3	3	4
Mechanical Efficiency [%]	91	89.3	87	83	81.7	75.5	65.7	60.5	0
Starting Mechanical Efficiency [%]	72.9	83.2	65	59.2	51	39	18	0	0
Continuous Maximum Power [kW]	98	91	78	65	53	39	28	14	0
Intermittent Maximum Power [kW]	121	112	96	80	65	48	35	17	0
Continuous Maximum Pressure [bar]	250	250	250	250	250	250	250	250	17
Intermittent Maximum Pressure [bar]	275	275	275	275	275	275	275	275	17
Peak Pressure [bar]	350	350	350	350	350	350	350	350	17
Recommended Flushing Flow [l/min]	12	12	12	12	12	12	12	12	15

Displacement [cc/Rev]	3085	2950	2790	2620	2460	2290	2130	1970	1800
Specific Theoretical Torque [Nm/bar]	49.1	47	44.4	41.7	39.2	36.5	33.9	31.4	28.7
Continuous Maximum Speed [rpm]	235	240	245	250	250	265	285	305	340
Minimum Speed [rpm]	1	1	1	1	1	1	1	1	1
Mechanical Efficiency [%]	95	94.5	94.2	94	93.7	93.5	92.8	92.3	92
Starting Mechanical Efficiency [%]	86	85.4	84.4	83.6	82.4	82	80.2	78	76
Continuous Maximum Power [kW]	175	175	175	165	155	150	140	130	122
Intermittent Maximum Power [kW]	196	196	196	185	174	168	157	146	137
Continuous Maximum Pressure [bar]	250	250	250	250	250	250	250	250	250
Intermittent Maximum Pressure [bar]	275	275	275	275	275	275	275	275	275
Peak Pressure [bar]	350	350	350	350	350	350	350	350	350
Recommended Flushing Flow [l/min]	12	12	12	12	12	12	12	12	12

Displacement [cc/Rev]	1640	1470	1310	1150	980	820	670	490	330
Specific Theoretical Torque [Nm/bar]	26.1	23.4	20.9	18.3	15.6	13.1	10.7	7.8	5.2
Continuous Maximum Speed [rpm]	370	400	425	455	490	520	600	600	600
Minimum Speed [rpm]	1	1	1	1	1	2	2	2	3
Mechanical Efficiency [%]	91	90.5	88	86.2	82.3	81.7	78	76	73.2
Starting Mechanical Efficiency [%]	73	70	66.4	62	55.4	46.3	33	0	0
Continuous Maximum Power [kW]	115	106	100	89	81	73	62	49	25
Intermittent Maximum Power [kW]	129	119	112	100	91	82	70	55	35
Continuous Maximum Pressure [bar]	250	250	250	250	250	250	250	250	250
Intermittent Maximum Pressure [bar]	275	275	275	275	275	275	275	275	275
Peak Pressure [bar]	350	350	350	350	350	350	350	350	350
Recommended Flushing Flow [l/min]	12	12	12	12	12	12	12	12	12



## TECHNICAL DATA

Displacement [cc/Rev]	4167	4177	3650	3280	2950	2620	2290	1970	1640
Specific Theoretical Torque [Nm/bar]	73.5	66.5	58.1	52.2	47	41.7	36.5	31.4	26.1
Continuous Maximum Speed [rpm]	150	158	168	175	210	235	275	305	380
Minimum Speed [rpm]	1	1	1	1	1	1	1	1	1
Mechanical Efficiency [%]	95.3	95.1	94.5	94.4	93.3	92.4	91.5	90.1	86.5
Starting Mechanical Efficiency [%]	85.1	84	83.3	82.5	81.2	80.1	78	75.2	72.4
Continuous Maximum Power [kW]	190	180	165	150	140	129	115	104	88
Intermittent Maximum Power [kW]	213	202	185	169	157	145	129	122	110
Continuous Maximum Pressure [bar]	250	250	250	250	250	250	250	250	250
Intermittent Maximum Pressure [bar]	275	275	275	275	275	275	275	275	275
Peak Pressure [bar]	350	350	350	350	350	350	350	350	350
Recommended Flushing Flow [l/min]	12	8	12	12	12	12	12	12	12

Displacement [cc/Rev]	1310	980	655	492	328	164	82	0
Specific Theoretical Torque [Nm/bar]	20.9	15.6	10.4	7.8	5.2	2.6	0	0
Continuous Maximum Speed [rpm]	435	460	495	520	550	1000	1000	1000
Minimum Speed [rpm]	1	1	2	2	3	3	4	0
Mechanical Efficiency [%]	83	78.4	76.2	66	46.4	0	0	0
Starting Mechanical Efficiency [%]	67.2	58	41	23.7	0	0	0	0
Continuous Maximum Power [kW]	73	56	38	27	15	0	0	0
Intermittent Maximum Power [kW]	96	80	56	39	20	0	0	0
Continuous Maximum Pressure [bar]	250	250	250	250	250	250	17	17
Intermittent Maximum Pressure [bar]	275	275	275	275	275	275	17	17
Peak Pressure [bar]	350	350	350	350	350	350	17	17
Recommended Flushing Flow [l/min]	12	12	12	12	12	12	15	15

Displacement [cc/Rev]	5236	5080	4915	4588	4097	3650	3280	2950	2620	2295
Specific Theoretical Torque [Nm/bar]	84.8	80.9	78.2	73	65.2	58.1	52.2	47	41.7	36.5
Continuous Maximum Speed [rpm]	130	135	140	150	160	170	190	215	230	280
Minimum Speed [rpm]	1	1	1	1	1	1	1	1	1	1
Mechanical Efficiency [%]	95.2	95	95	95	95	94.4	94.3	93.2	92	91.5
Starting Mechanical Efficiency [%]	86	85.8	85.8	85.4	85.2	83	82.2	82	79.8	77.7
Continuous Maximum Power [kW]	190	190	190	190	178	162	152	140	130	120
Intermittent Maximum Power [kW]	216	216	216	216	200	182	170	160	145	135
Continuous Maximum Pressure [bar]	250	250	250	250	250	250	250	250	250	250
Intermittent Maximum Pressure [bar]	275	275	275	275	275	275	275	275	275	275
Peak Pressure [bar]	350	350	350	350	350	350	350	350	350	350
Recommended Flushing Flow [l/min]	12	12	12	12	12	12	12	12	12	12

Displacement [cc/Rev]	1970	1640	1560	1311	980	655	492	328	164	0
Specific Theoretical Torque [Nm/bar]	31.4	26.1	24.8	20.9	15.6	10.4	7.8	5.2	2.6	0
Continuous Maximum Speed [rpm]	335	375	410	445	470	500	520	550	1000	1000
Minimum Speed [rpm]	1	1	1	1	1	2	2	3	3	0
Mechanical Efficiency [%]	90	86	84.5	82.3	78.3	76.2	66.2	46.5	0	0
Starting Mechanical Efficiency [%]	75.3	72.1	71.3	67	58	41	24	0	0	0
Continuous Maximum Power [kW]	105	90	85	75	58	40	26	15	0	0
Intermittent Maximum Power [kW]	120	110	102	98	82	56	40	20	0	0
Continuous Maximum Pressure [bar]	250	250	250	250	250	250	250	250	17	17
Intermittent Maximum Pressure [bar]	275	275	275	275	275	275	275	275	17	17
Peak Pressure [bar]	350	350	350	350	350	350	350	350	17	17
Recommended Flushing Flow [l/min]	12	12	12	12	12	12	12	12	15	15

YIAC 4600 H7



YIAC 5400 H7

# Single-Two Speed Wheel Drives



## YW 05 SERIES

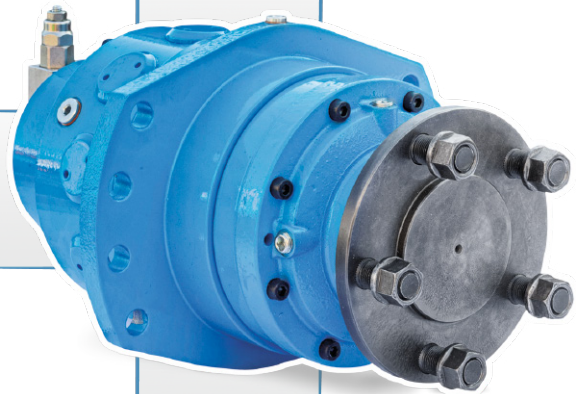

### TECHNICAL DATA

#### SINGLE DISPLACEMENT

Gear Code	Gear Ratio	Motor Displacement cc/Rev	Output Torque		Working Pressure		Total Displacement cc/Rev	Max Output Speed Rpm	Max Freewheeling Speed Rpm	Max Power	
			Continuos	Maximum	Continuos	Maximum				Kw	Hp
			Nm	Nm	bar	bar					
1	1:3.55	101.6	1400	1970	250	350	361	620	560	60	82
2	1:4.28	101.6	1680	2350	250	350	432	520	470	60	82
3	1:5.6	101.6	2250	3100	250	350	565	390	360	60	82
4	1:6.75	101.6	2700	3800	250	350	681	325	300	60	82

#### DUAL DISPLACEMENT

##### Maximum Displacement Technical Data

Gear Code	Gear Ratio	Motor Displacement cc/Rev	Output Torque		Working Pressure		Total Displacement cc/Rev	Max Output Speed Rpm	Max Freewheeling Speed Rpm	Max Power	
			Continuos	Maximum	Continuos	Maximum				Kw	Hp
			Nm	Nm	bar	bar					
1	1:3.55	101.6	1400	1970	250	350	361	620	560	60	82
2	1:4.28	101.6	1680	2350	250	350	432	520	470	60	82
3	1:5.6	101.6	2250	3100	250	350	565	390	360	60	82
4	1:6.75	101.6	2700	3800	250	350	681	325	300	60	82

#### DUAL DISPLACEMENT

##### Minimum Displacement Technical Data

Gear Code	Gear Ratio	Motor Displacement cc/Rev	Output Torque		Working Pressure		Total Displacement cc/Rev	Max Output Speed Rpm	Max Freewheeling Speed Rpm	Max Power	
			Continuos	Maximum	Continuos	Maximum				Kw	Hp
			Nm	Nm	bar	bar					
1	1:3.55	50.9	700	985	250	350	180	670	560	23	32
2	1:4.28	50.9	840	1175	250	350	216	560	470	23	32
3	1:5.6	50.9	970	1410	250	350	283	430	360	23	32
4	1:6.75	50.9	1060	1700	250	350	341	355	300	23	32

YW 05 - G100

YW 05 - GD100



## YW 08 SERIES

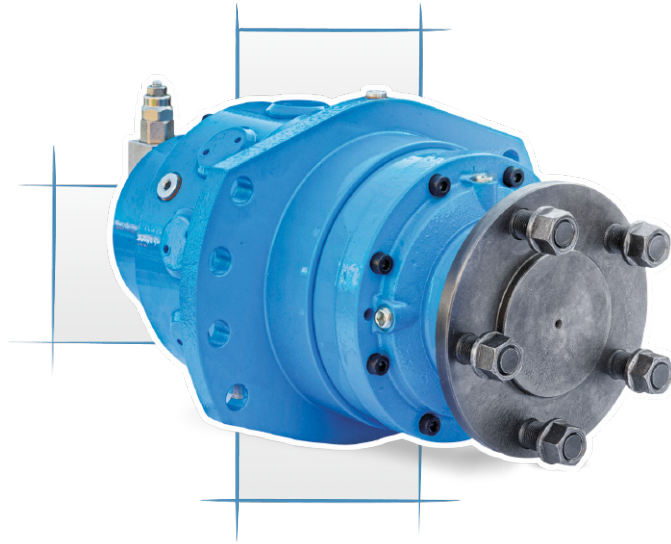

### TECHNICAL DATA

#### SINGLE DISPLACEMENT

Gear Code	Gear Ratio	Output Torque		Working Pressure		Total Displacement	Max Output Speed	Max Freewheeling Speed	Max Power	
		Continuos	Maximum	Continuos	Maximum				Kw	Hp
		Nm	Nm	bar	bar					
1	1:3.77	3400	4600	250	350	856	160	220	55	75
2	1:4.12	3700	5100	250	350	935	145	200	55	75
3	1:5.16	4650	6500	250	350	1171	115	155	55	75
4	1:6	5400	7500	250	350	1362	100	135	55	75

#### DUAL DISPLACEMENT

##### Maximum Displacement Technical Data

Gear Code	Gear Ratio	Output Torque		Working Pressure		Total Displacement	Max Output Speed	Max Freewheeling Speed	Max Power	
		Continuos	Maximum	Continuos	Maximum				Kw	Hp
		Nm	Nm	bar	bar					
1	1:3.77	4350	6100	250	350	1090	135	185	60	82
2	1:4.12	4750	6600	250	350	1191	120	170	55	82
3	1:5.16	6000	8400	250	350	1491	100	135	55	82
4	1:6	6900	9700	250	350	1734	85	120	55	82

#### DUAL DISPLACEMENT

##### Minimum Displacement Technical Data

Gear Code	Gear Ratio	Motor Displacement	Output Torque		Working Pressure		Total Displacement	Max Output Speed	Max Freewheeling Speed	Max Power	
			Continuos	Maximum	Continuos	Maximum				Kw	Hp
			cc/Rev	Nm	Nm	bar					
1	1:3.55	50.9	700	985	250	350	180	670	560	23	32
2	1:4.28	50.9	840	1175	250	350	216	560	470	23	32
3	1:5.6	50.9	970	1410	250	350	283	430	360	23	32
4	1:6.75	50.9	1060	1700	250	350	341	355	300	23	32

YW 08 - HC05

YW 08 - HC1

## YSTFC (HD) SERIES

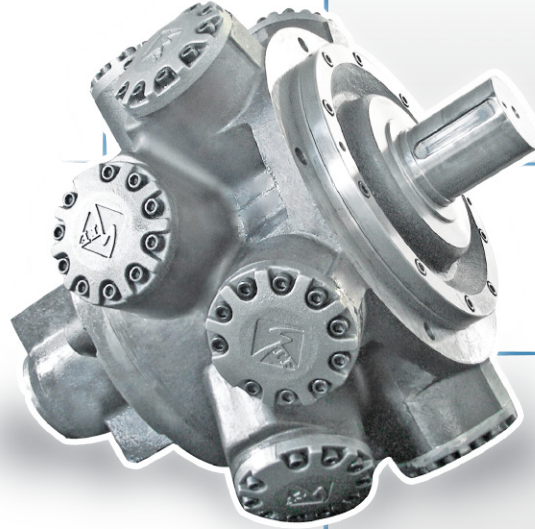

This series of motor is based on the “hydraulically balanced piston rod” technology. Offering high efficiency, low noise, constant torque and long life even in the most severe applications

### TECHNICAL DATA

TYPE	Displacement				Pressure				Rated Torque		Unit Torque		Speed Range	Weight	
	nominal		theory		Rated pressure		Max Pressure		N.m	Lb/Ft	N.m/MPA	Lb/Ft/PSI	r/min	kg	lbs
	mL/r	in <sup>3</sup> /rev	mL/r	in <sup>3</sup> /rev	MPA	PSI	MPA	PSI							
YSTFC 080	1000	61	988	60.3	23	3335	29	4205	3243	2392	141	0.72	280	144	318
	1100	67	1088	66.4	23	3335	29	4205	3565	2629	155	0.79	280		
	1250	76.3	1237	75.5	23	3335	29	4205	3910	2884	170	0.86	280		
YSTFC 100	1400	85.43	1385	84.5	23	3335	29	4205	4554	3359	198	1.01	240	144	318
	1650	100.7	1630	99.5	23	3335	29	4205	5405	3987	235	1.20	240		
YSTFC 125	1400	85.4	1459	89	23	3335	29	4205	4807	3545	209	1.06	210	235	518
	1600	97.6	1621	98.8	23	3335	29	4205	5336	3936	232	1.18	210		
	1800	110	1864	113.7	21	3045	29	4205	5586	4120	266	1.35	160		
	2000	122	2027	123.7	21	3045	29	4205	6090	4492	290	1.48	160		
YSTFC 200	2400	146.5	2432	148.4	23	3335	29	4205	8188	6039	356	1.81	175	285	628
	2800	170.8	2757	168.2	23	3335	29	4205	9269	6836	403	2.05	150		
	3100	189	3080	188	21	3045	29	4205	9471	6985	451	2.29	135		
YSTFC 270	3300	201.4	3291	200.8	23	3335	29	4205	11063	8160	481	2.45	125	420	926
	3600	219.7	3575	218.2	23	3335	29	4205	12029	8872	523	2.66	125		
	4000	244.1	3973	242.4	21	3045	29	4205	12201	8999	581	2.96	100		
	4300	262.4	4313	263.2	21	3045	29	4205	13251	9773	631	3.21	100		
YSTFC 325	4500	274.6	4538	276.9	23	3335	29	4205	15272	11264	664	3.38	100	430	948
	5000	305.1	4992	304.6	23	3335	29	4205	16790	12384	730	3.71	100		
	5400	329.5	5310	324.1	21	3045	29	4205	16317	12035	777	3.95	100		
YSTFC 400	5500	335.6	5510	336.2	23	3335	29	4205	18538	13673	806	4.10	120	495	1090
	6000	366.1	5996	365.9	23	3335	29	4205	20171	14877	877	4.46	120		
	6500	396.7	6483	395.6	21	3045	29	4205	19908	14683	948	4.82	120		
	6800	415	6807	415.4	21	3045	29	4205	20916	15427	996	5.07	120		

YSTFC (HD)

## YSTFD (HD) SERIES

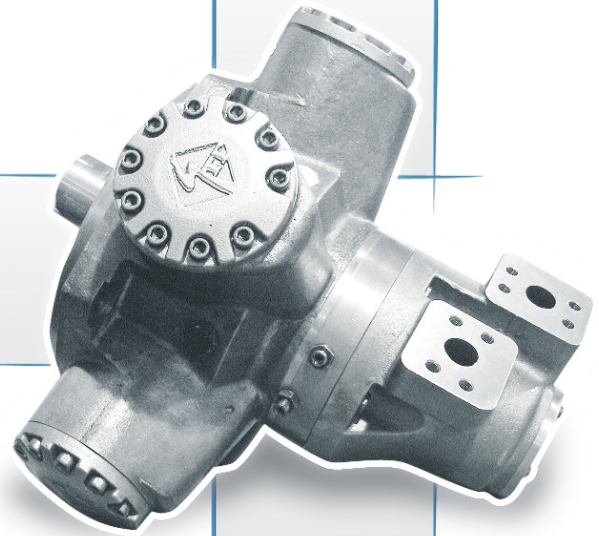

This is a “two-speed” variation of the YSTFC. This series is based on the variable crankshaft which permits the motor to go from maximum displacement to zero during motion with a very smooth and constant torque output. By reducing the displacement and increasing the speed, we can meet many application requirements.

### TECHNICAL DATA

<b>(HD) 100</b>																	
<b>Nominal displacement</b>		1600	1500	1400	1300	1200	1100	1000	900	800	700	600	500	400	300	200	100
<b>Displacement</b>	ml/r	1580	1481	1383	1284	1185	1086	987	889	790	691	592	494	395	296	197	98
	in <sup>3</sup> /r	96.4	90.3	84.4	78.3	72.3	66.3	60.2	54.7	48.2	42.2	36.1	30.1	24.1	18.1	12.0	6.0
<b>Unit Torque</b>	N.m/Mpa	225	212	198	184	169	155	140	125	108	94	78	68	45	30	18	0
	lb-ft/PSI	1.148	1.081	1.010	0.938	0.862	0.791	0.714	0.680	0.551	0.499	0.398	0.347	0.230	0.153	0.092	0
<b>Max. Cont. Speed</b>	r/min	260	270	280	300	330	370	405	485	540	540	540	540	540	540	540	900
<b>Max. Cont Power</b>	KW	99	98	96	93	90	84	82	79	74	69	57	46	35	23	10	0
	HP	132.7	131.3	128.6	124.6	120.6	112.6	109.9	105.9	99.2	92.5	76.4	61.6	46.9	30.8	13.4	0
<b>Max. Top Power</b>	KW	120	117	113	109	105	100	97	93	87	81	68	54	40	28	14	0
	HP	160.8	156.8	151.4	146.1	140.7	134.0	129.0	124.6	116.6	108.5	91.1	72.4	53.6	37.5	18.8	0
<b>Max. Cont Pressure</b>	Mpa	21	21	21	21	21	21	21	21	21	21	21	21	21	21	21	15
	PSI	3045	3045	3045	3045	3045	3045	3045	3045	3045	3045	3045	3045	3045	3045	3045	2175
<b>Max. Top Pressure</b>	Mpa	25	25	25	25	25	25	25	25	25	25	25	25	25	25	25	15
	PSI	3625	3625	3625	3625	3625	3625	3625	3625	3625	3625	3625	3625	3625	3625	3625	2175

<b>(HD) 125</b>																	
<b>Nominal displacement</b>		2100	2000	1800	1600	1500	1300	1200	1000	830	670	510	350	190	110		
<b>Displacement</b>	ml/r	2066	1973	1811	1649	1487	1325	1163	1001	839	677	515	353	191	110		
	in <sup>3</sup> /r	126.1	120.4	110.5	118.9	90.7	80.8	70.9	61.1	51.2	41.3	31.4	21.5	11.6	6.6		
<b>Unit Torque</b>	N.m/Mpa	293	281	258	231	206	180	154	125	100	79	57	39	6	0		
	lb-ft/PSI	1.494	1.433	1.316	1.178	1.051	0.918	0.785	0.680	0.510	0.403	0.241	0.199	0.031	0		
<b>Max. Cont. Speed</b>	r/min	170	175	190	210	230	265	305	350	395	485	540	540	540	900		
<b>Max. Cont Power</b>	KW	91	89	83	77	71	66	60	55	48	42	33	16	3	0		
	HP	121.9	119.1	111.2	103.2	95.1	88.4	80.4	73.7	64.3	56.3	44.2	21.4	4.0	0		
<b>Max. Top Power</b>	KW	106	104	99	95	90	85	79	73	65	57	44	28	5	0		
	HP	142.0	139.4	132.7	127.3	120.6	113.9	105.9	97.8	87.1	76.4	58.9	37.5	6.7	0		
<b>Max. Cont Pressure</b>	Mpa	21	21	21	21	21	21	21	21	21	21	21	21	21	15		
	PSI	3045	3045	3045	3045	3045	3045	3045	3045	3045	3045	3045	3045	3045	2175		
<b>Max. Top Pressure</b>	Mpa	25	25	25	25	25	25	25	25	25	25	25	25	25	15		
	PSI	3625	3625	3625	3625	3625	3625	3625	3625	3625	3625	3625	3625	3625	2175		

YSTFD (HD)



## TECHNICAL DATA



### (HD) 200

<b>Nominal displacement</b>		3100	2900	2800	2600	2400	2300	2100	2000	1800	1600	1500	1300	1200	1000	830	670	510	350	190	110
<b>Displacement</b>	ml/r	3080	2958	2796	2634	2472	2310	2148	1973	1811	1649	1487	1325	1163	1001	839	677	515	353	191	110
	in <sup>3</sup> /R	187.9	180.5	170.6	160.7	156.8	140.9	131.1	120.4	110.5	100.6	90.7	80.8	70.9	61.1	51.2	41.3	31.4	21.5	11.6	6.6
<b>Unit Torque</b>	N.m/Mpa	447	422	400	375	351	326	300	281	258	231	206	180	154	125	100	79	57	30	6	0
	lb-ft/PSI	2.280	2.152	2.040	1.913	1.790	1.630	1.530	1.433	1.316	1.178	1.051	0.918	0.785	0.638	0.510	0.403	0.291	0.153	0.031	0
<b>Max.Cont.Speed</b>	r/min	110	115	125	135	140	150	160	175	190	210	230	265	305	350	395	485	540	540	540	900
<b>Max. Cont Power</b>	KW	110	110	110	105	100	96	92	89	83	77	71	66	60	55	48	42	33	16	3	0
	HP	147.4	147.4	147.4	140.7	134.0	128.6	123.3	119.3	111.2	103.2	95.1	88.4	80.4	73.2	64.3	56.3	44.2	21.4	4.0	0
<b>Max. Top Power</b>	KW	135	135	135	130	125	120	114	104	99	95	90	85	79	73	65	57	44	28	5	0
	HP	180.9	180.9	180.9	174.2	167.5	160.8	152.8	139.4	132.7	127.3	120.6	113.9	105.9	97.8	87.1	76.3	58.9	37.5	6.7	0
<b>Max. Cont Pressure</b>	Mpa	21	21	21	21	21	21	21	21	21	21	21	21	21	21	21	21	21	21	21	15
	PSI	3045	3045	3045	3045	3045	3045	3045	3045	3045	3045	3045	3045	3045	3045	3045	3045	3045	3045	3045	3045
<b>Max. Top Pressure</b>	Mpa	25	25	25	25	25	25	25	25	25	25	25	25	25	25	25	25	25	25	25	15
	PSI	3625	3625	3625	3625	3625	3625	3625	3625	3625	3625	3625	3625	3625	3625	3625	3625	3625	3625	3625	2175

### (HD) 270

<b>Nominal displacement</b>		4600	4100	3600	3300	3000	2600	2300	1900	1600	1400	970	680	340	170
<b>Displacement</b>	ml/r	4597	4086	3632	3291	2951	2610	2270	1930	1646	1362	965	681	340	170
	in <sup>3</sup> /R	280.5	249.3	221.6	200.8	180.1	159.2	138.5	117.8	100.4	83.1	58.9	41.5	20.7	10.4
<b>Unit Torque</b>	N.m/Mpa	657	585	514	460	419	356	310	259	210	168	108	73	24	0
	lb-ft/PSI	3.351	2.983	2.621	2.346	2.137	1.816	1.581	1.321	1.071	0.857	0.551	0.372	1.22	0
<b>Max.Cont.Speed</b>	r/min	108	120	135	145	165	180	215	240	290	315	315	315	315	900
<b>Max. Cont Power</b>	KW	123	115	104	97	90	83	76	68	59	48	37	25	8	0
	HP	164.8	154.1	139.4	129.9	120.6	111.2	101.8	91.1	79.1	64.3	49.6	33.5	10.7	0
<b>Max. Top Power</b>	KW	153	149	142	136	129	122	112	102	91	81	68	47	12	0
	HP	205.0	199.7	190.3	182.2	172.9	163.5	150.1	136.7	121.9	108.5	91.1	62.9	16.1	0
<b>Max. Cont Pressure</b>	Mpa	21	21	21	21	21	21	21	21	21	21	21	21	21	15
	PSI	3045	3045	3045	3045	3045	3045	3045	3045	3045	3045	3045	3045	3045	2175
<b>Max. Top Pressure</b>	Mpa	25	25	25	25	25	25	25	25	25	25	25	25	25	15
	PSI	3625	3625	3625	3625	3625	3625	3625	3625	3625	3625	3625	3625	3625	2175

### (HD) 325

<b>Nominal displacement</b>		5300	5100	4900	3600	3300	3000	2600	2300	1900	1600	1500	1400
<b>Displacement</b>	ml/r	5335	5108	4937	3632	3291	2951	2610	2270	1930	1646	1532	1362
	in <sup>3</sup> /R	325.5	311.5	301.7	221.6	200.8	180.0	159.2	138.5	117.8	100.4	93.5	83.1
<b>Unit Torque</b>	N.m/Mpa	763	731	706	514	460	419	356	310	259	210	196	168
	lb-ft/PSI	3.891	3.728	3.600	2.621	2.346	2.137	1.816	1.581	1.321	1.071	10.00	8.57
<b>Max.Cont.Speed</b>	r/min	90	105	110	135	145	165	180	215	240	290	315	315
<b>Max. Cont Power</b>	KW	123	123	123	104	97	90	83	76	68	59	54	48
	HP	164.8	164.8	164.8	139.4	129.9	120.6	111.2	101.8	91.1	79.1	72.4	64.3
<b>Max. Top Power</b>	KW	153	153	153	142	136	129	122	112	102	91	87	81
	HP	205.0	205.0	205.0	190.3	182.2	172.9	163.5	150.1	136.7	121.9	116.6	108.5
<b>Max. Cont Pressure</b>	Mpa	21	21	21	21	21	21	21	21	21	21	21	15
	PSI	3045	3045	3045	3045	3045	3045	3045	3045	3045	3045	3045	2175
<b>Max. Top Pressure</b>	Mpa	25	25	25	25	25	25	25	25	25	25	25	15
	PSI	3625	3625	3625	3625	3625	3625	3625	3625	3625	3625	3625	2175

YSTFD (HD)





## YGR S-F 5500

Continuous Rotation	360
Working Pressure	2600 PSI
Max Pressure	3200 PSI
Max Output Torque	19,500 Lb-In
Max Static Load	22,000 Lbs
Grapple Pressure	5000 PSI
Weight	130 Lbs

## YGR F 7000

Continuous Rotation	360
Working Pressure	2600 PSI
Max Pressure	3200 PSI
Max Output Torque	7000 Lb-In
Max Static Load	7000 Lbs
Grapple Pressure	5000 PSI
Weight	50 Lbs



## YGR F 10000

Continuous Rotation	360
Working Pressure	2600 PSI
Max Pressure	3200 PSI
Max Output Torque	9200 Lb-In
Max Static Load	10,000 Lbs
Grapple Pressure	5000 PSI
Weight	62 Lbs

## YGR F 13000

Continuous Rotation	360
Working Pressure	2600 PSI
Max Pressure	3200 PSI
Max Output Torque	14,000 Lb-In
Max Static Load	13,000 Lbs
Grapple Pressure	5000 PSI
Weight	110 Lbs



## YGR F 22000

Continuous Rotation	360
Working Pressure	2600 PSI
Max Pressure	3200 PSI
Max Output Torque	19,500 Lb-In
Max Static Load	22,000 Lbs
Grapple Pressure	5000 PSI
Weight	130 Lbs



**Boom Lifts**

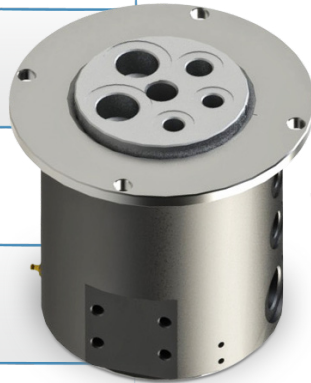

**Excavators**



**Concrete Pumps  
Fire Apparatus**



**Cranes**

**Bottling Machines**

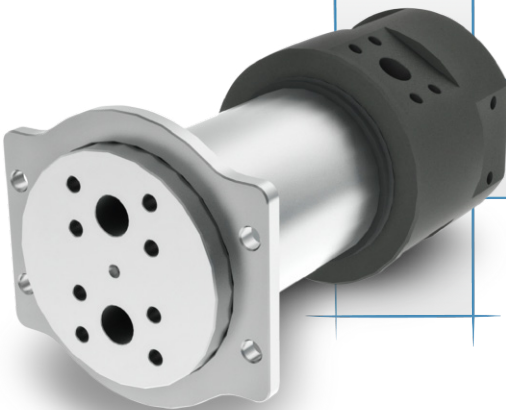

**Demolition Scissors**

## **Hydraulic Swivels**

From 2 to 36 Ports

"O" Rings or SAE Flanged Ports

Up to 6000 PSI Working Pressure

ZERO "O" Leakage

For Oil, Water, Air and other liquid

And many other applications

# Electric Swivels



Integral or Add-on  
From 1 to 48 Contacts  
From 12 to 96 Volts  
Up to 60 Amp  
Waterproof

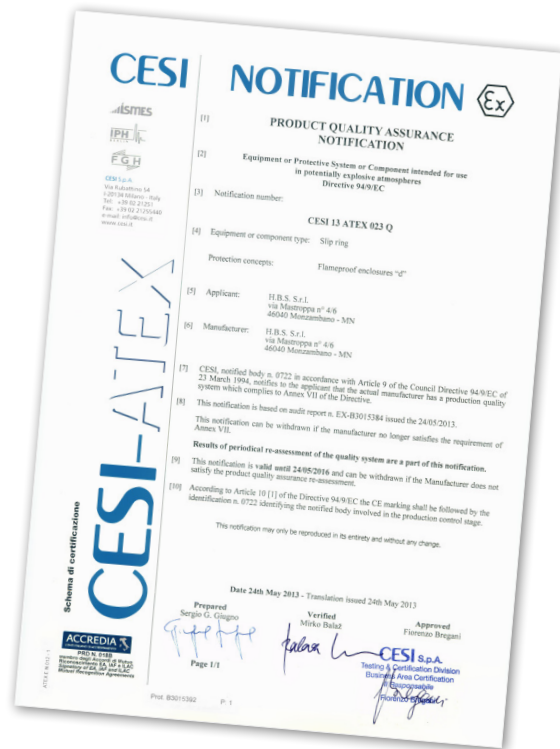

## CAN/BUS connection

We deliver solutions from one source

YFC51



## Full range pressure compensating variable flow control 'YFC'

YFC51

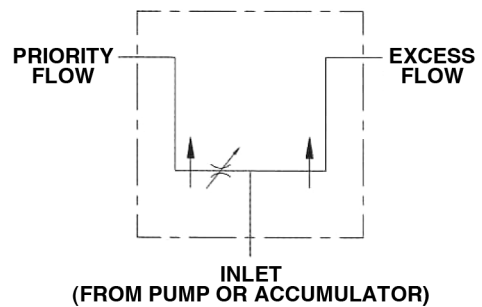

YFCR51



YFCR51

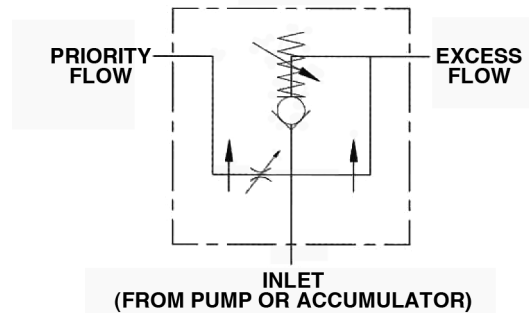

### Specifications

- Pressure Rating: 0 - 3000 PSI
- Flow Rating: 30 gpm/115 LPM
- Cast Iron Body
- Buna Seals

Units with relief valve are field adjustable 800 - 3000 PSI



## DIMENSIONAL DATA

**YFCR51 shown**

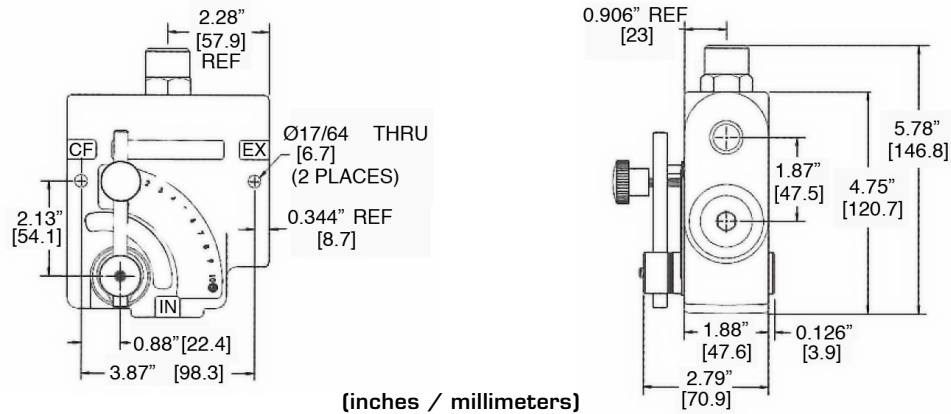

## MODEL CODES

### Pressure Compensating Flow Control Valve

- YFC51-10 — SAE#10 Ports
- YFC51-12 — SAE#12 Ports
- YFC51-50 — 1/2" NPT Ports
- YFC51-75 — 3/4" NPT Ports
- YFC51-8 — SAE#8 Ports

### Pressure Compensating Flow Control Valve W/RELIEF

- YFCR51-10 — SAE#10 Ports
- YFCR51-12 — SAE#12 Ports
- YFCR51-50 — 1/2" NPT Ports
- YFCR51-75 — 3/4" NPT Ports
- YFCR51-8 — SAE#8 Ports



**YBP  
YBM  
SERIES**

**TANG  
shaft**

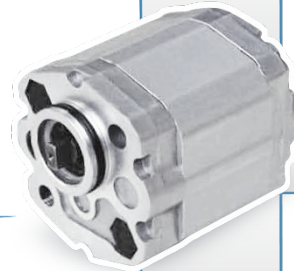

**SAE A+B  
mounts**

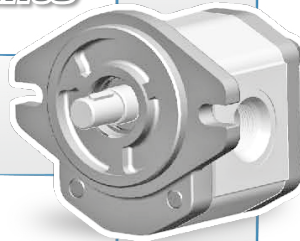

**ENGINE  
mounts**

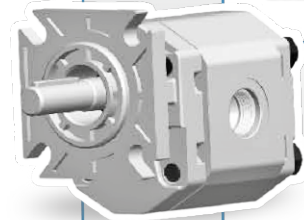

**TANDEM  
units**

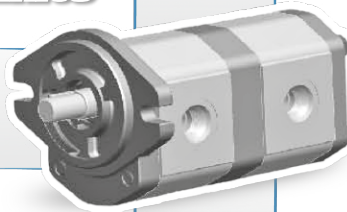

**SAE AA  
mounts**

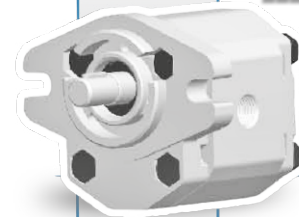

**REAR  
porting**

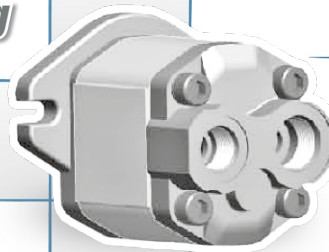

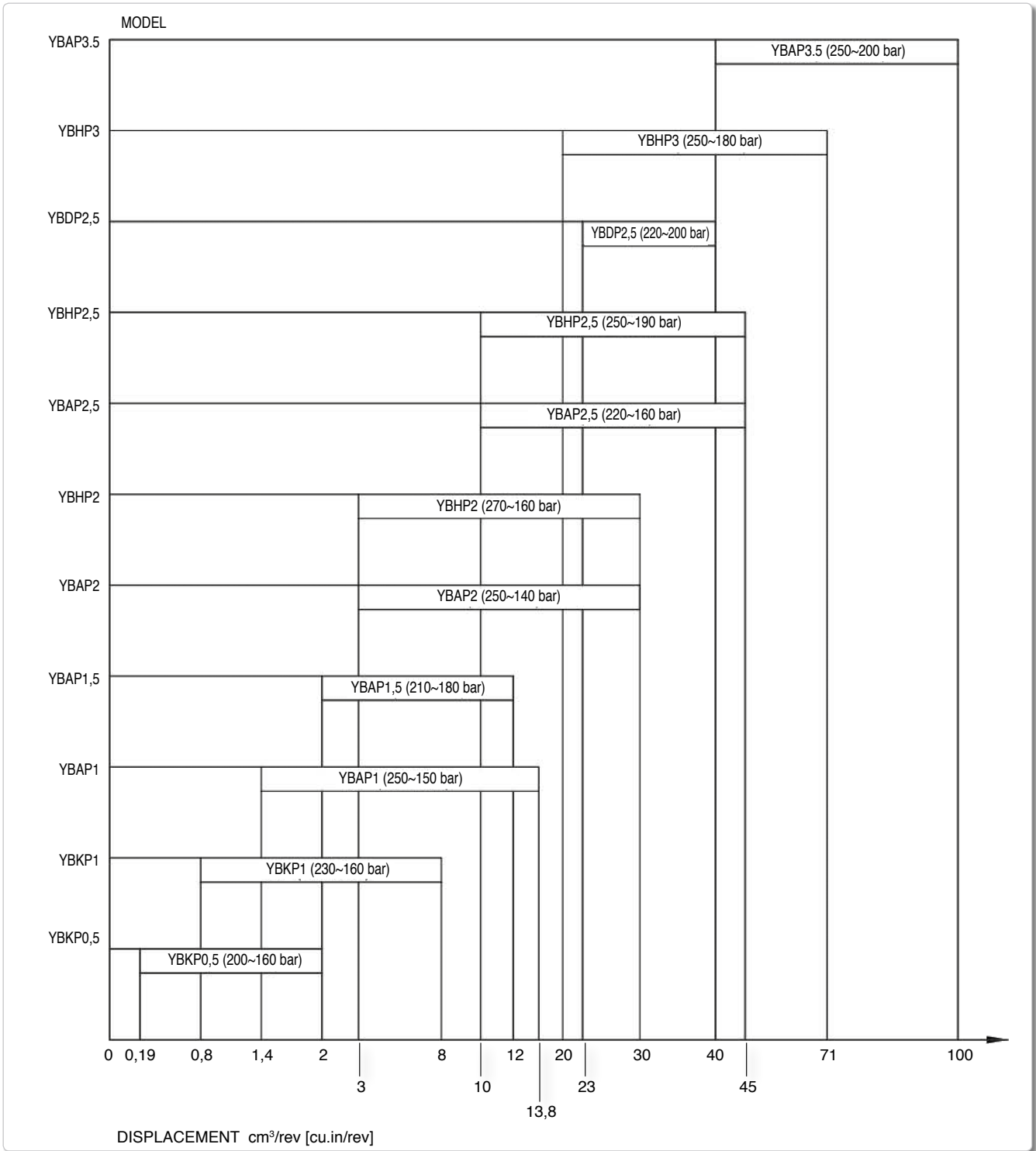

Remark: The shown pressure in the graph is to be considered as "MAXIMUM CONTINUOUS PRESSURE". Product series "YBH" has "Cast Iron" front and end covers. All other have aluminum covers

# Close Circuit Piston Pumps and Motors

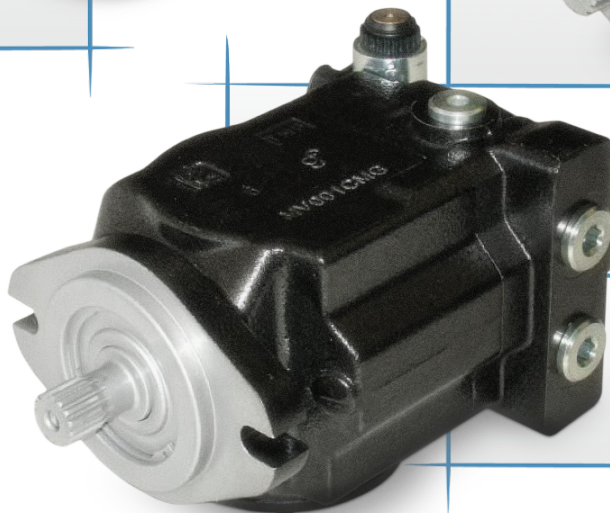
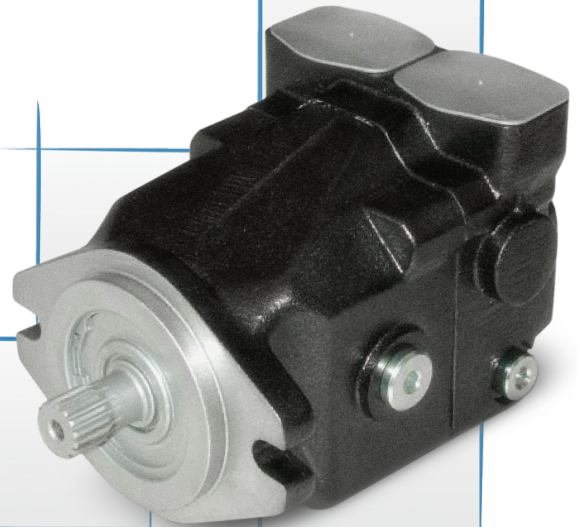
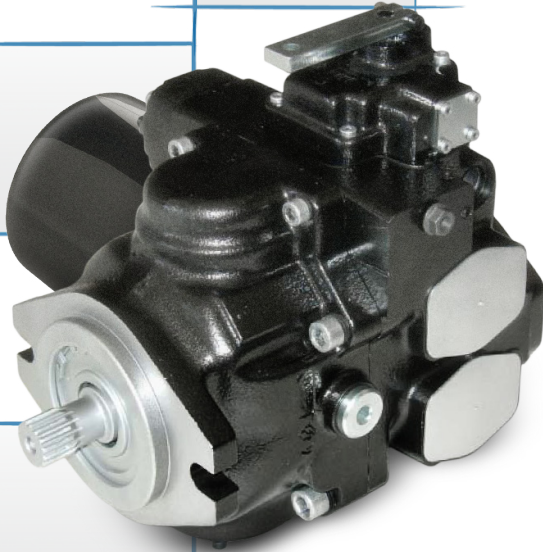
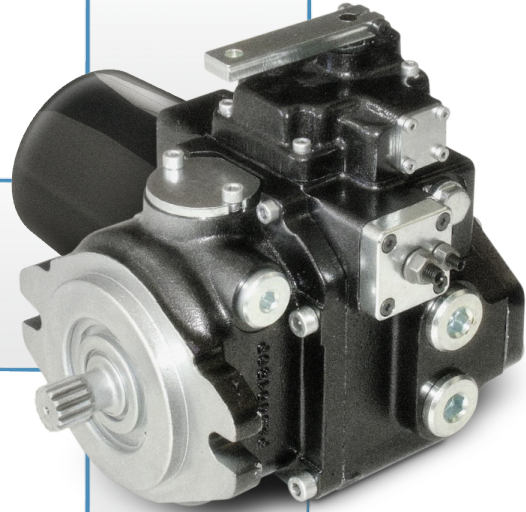
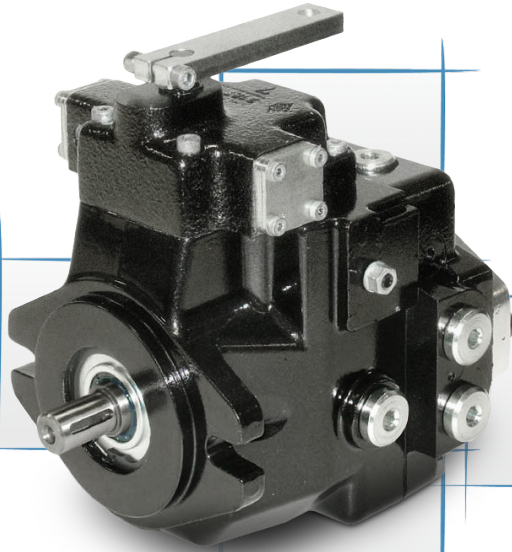



## CLOSE LOOP PUMP AXIAL PISTON **C1-14/18** SERIES

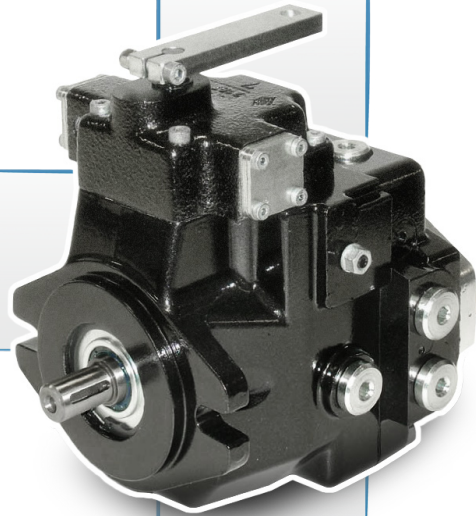

### TECHNICAL DATA

Displacement	14 cc	0.855 CIR
	18 cc	1.099 CIR
Mounting Flange	SAE	"A"
Charge Pump	5.4 CC	0.330 CIR
Maximum Speed	3600 rpm	3600 rpm
Minimum Speed	700 rpm	700 rpm
Nominal Pressure	210 bar	3000 Psi
Maximum Pressure	270 bar	3915 Psi
Charging Pressure	20 bar	290 Psi
Max Case Pressure	2 bar	29 Psi
Suction Pressure	0.8 bar	11.6 Psi
Inertia Kg M1 / Lb-Ft	0.0014	0.033
Weight	7 Kg	15.5 Lbs

Peak operations must not exceed 1% of every minute. A simultaneous maximum pressure and maximum speed are not recommended.

#### Notes:

(1) The displacements 14/18 use the same external casing.

(2) The values shown are valid for an absolute pressure (pass) of 1 bar (14.5 psi) at the suction inlet port an when operated on mineral oil.

(3) Approximate values.

### Options

- 16/32 DP 9 T Shaft
- Pressure Filter
- UNF Ports
- Electric Cut-off

### Controls

- Manual without zeroing
- Manual with zeroing
- Hydraulic proportional without feed-back
- Hydraulic proportional with feed-back
- Manual lever with feed-back
- Two (2) position electric ON/OFF
- Electric Impulse

C1 - 14/18



# Close Circuit Piston Pumps



## CLOSE LOOP PUMP AXIAL PISTON **C2-21/28** SERIES

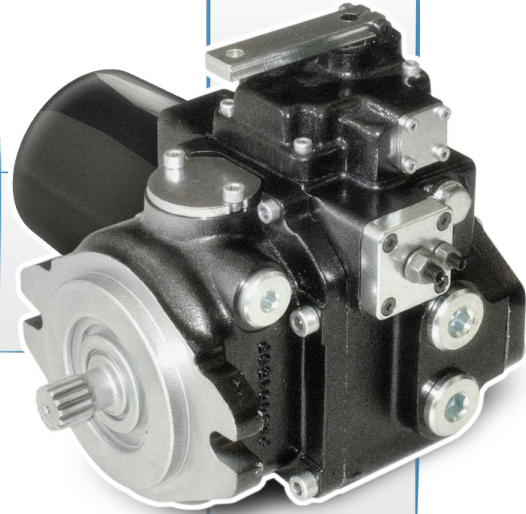

### TECHNICAL DATA

Displacement	21 cc	1.282 CIR
	28 cc	1.709 CIR
Mounting Flange	SAE "B"	SAE "B"
Charge Pump	11 CC	0.672 CIR
Maximum Speed	3600 rpm	3600 rpm
Minimum Speed	700 rpm	700 rpm
Nominal Pressure	210 bar	3000 Psi
Maximum Pressure	350 bar	5075 Psi
Charging Pressure	20 bar	290 Psi
Max Case Pressure	2 bar	29 Psi
Suction Pressure	0.8 bar	11.6 Psi
Inertia Kg M1 / Lb-Ft	0.0014	0.033
Weight	7 Kg	15.5 Lbs

Peak operations must not excide 1% of every minute. A simultaneous maximum pressure and maximum speed are not recommended.

#### Notes:

(1) The displacements 21/28 use the same external casing.

(2) The values shown are valid for an absolute pressure (pass) of 1 bar (14.5 psi) at the suction inlet port an when operated on mineral oil.

(3) Approximate values.

### Options

- 16/32 DP 13 T
- 16/32 DP 15 T
- Bypass Valve
- Pressure Filter
- UNF Ports
- Hot Oil Valve
- Power Limiter
- Mechanical or Hydraulic inching
- Pressure Cut-off
- Additional Pressure Gage Port

### Controls

- Hydraulic proportional without feed-back
- Hydraulic proportional with feed-back
- Electric proportional without feed-back
- Electric proportional with feed-back
- Electric 2 position ON/OFF
- Electric Impulse
- Auto

C2 - 21/28

46



## CLOSE LOOP PUMP AXIAL PISTON C3-46/50/64 SERIES

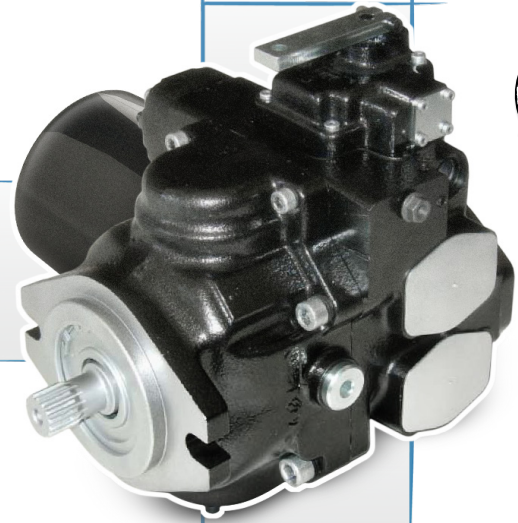

### TECHNICAL DATA

Displacement	46 cc	2.80 CIR
	50 cc	3.05 CIR
	64 cc	3.9 CIR
Mounting Flange	SAE "B"	SAE "B"
Charge Pump	13 CC	0.79 CIR
Maximum Speed	3600 rpm	3600 rpm
Minimum Speed	700 rpm	700 rpm
Nominal Pressure	250 bar	3625 Psi
Maximum Pressure	400 bar	5800 Psi
Charging Pressure	22 bar	319 Psi
Max Case Pressure	2 bar	29 Psi
Suction Pressure	0.8 bar	11.6 Psi
Inertia Kg M1 / Lb-Ft	0.0046	0.109
Weight	29 Kg	64 Lbs

Peak operations must not excide 1% of every minute. A simultaneous maximum pressure and maximum speed are not recommended.

#### Notes:

(1) The displacements 46/50/64 use the same external casing.

(2) The values shown are valid for an absolute pressure (pass) of 1 bar (14.5 psi) at the suction inlet port and when operated on mineral oil.

(3) Approximate values.

### Options

- 16/32 DP 15 T Shaft
- Pressure Relief Valve
- Pressure Filter W or W/O sensor
- UNF Ports
- Hot Oil Valve
- Power Limiter
- Mechanical or Hydraulic inching
- Electric Pressure Cut-off 12/24 V

### Controls

- Hydraulic proportional without feed-back
- Hydraulic proportional with feed-back
- Manual without feed-back
- Manual with feed-back
- Electric Impulse 12 or 24 V
- Auto

C3 - 46/50/64

# Fixed Displacement Axial Piston Motors



## FIXED DISPLACEMENT AXIAL PISTON MOTORS 34/46/50/64 SERIES

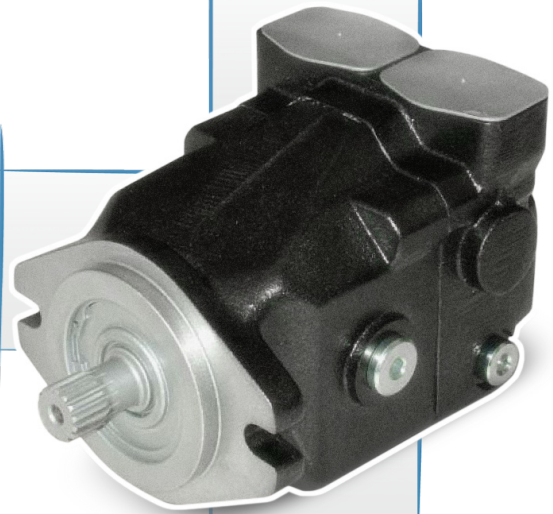

### TECHNICAL DATA

Displacement		34 cc	46 cc	50 cc	64 cc
Max Rotation Speed Continuous	min <sup>-1</sup>	3600	3600	3600	3600
Max Rotation Speed Intermittent	min <sup>-1</sup>	3800	3800	3800	3800
Pressure Rating	bar	250	250	250	250
Peak Pressure	bar	400	400	400	400
Max Housing Pressure	bar	1.5	1.5	1.5	1.5
Max Oil Continuous Temperature	°C	80	80	80	80
ISO Filtration Class		ISO 18/16/13, NAS 8			
Optimized Oil Viscosity	mm <sup>2</sup> /s	15-35	15-35	15-35	15-35
Weight	Kg	13	13	13	13
Inertial Mess	N·m·s <sup>2</sup>	60 x 10 <sup>-4</sup>	60 x 10 <sup>-4</sup>	59 x 10 <sup>-4</sup>	59 x 10 <sup>-4</sup>

The fixed-displacement axial piston motors feature a swashplate-system and may operate in either closed or open circuit. Proper selection of materials and the use of steel cylinder blocks with inserted bushings guarantee the highest performance of the motors, in terms of max. speed and working pressure.

### Options

- Clockwise Rotation
- Counterclockwise Rotation
- 13/16 DP 15T Shaft
- SAE "B" 2 Bolts Flange
- "A" - "B" Ports 1-1/16-12 UN
- Drain 1-1/16-12 UN
- Hot Oil Valve
- Side Ports
- Rear Ports

### Main Features

- Exceptionally high power/weight ratio
  - Excellent volumetric and mechanical efficiency
  - Long life
  - Compact design
  - Exchange valve fitted as optional
- All dimensions are unchanged

34/46/50/64

48

# Variable Displacement Axial Piston Motors

VARIABLE DISPLACEMENT AXIAL PISTON MOTORS

## 46/50/65 SERIES



### TECHNICAL DATA

Displacement	46 cc	2.51 CIR
	50 cc	3.05 CIR
	65 cc	3.97 CIR
Continuous Pressure	280 bar	4060 psi
Intermittent Pressure	315 bar	4560 psi
Peak Pressure	350 bar	5075 psi
Minimum Output Speed	700 rpm	700 rpm
Maximum Output Speed	4000 rpm	4000 rpm
Weight	20 Kg	41 Lbs

The variable-displacement axial piston motors have been designed to work both in an open and closed circuit. Available control systems are making it easy to use these motors in any applications for industrial and mobile field.

### Options

- Reversing Rotation
- Electric 12V or 24V Control
- Hydraulic Remote Control
- 13/16 DP 15T Shaft
- SAE "B" 2 Bolts Flange
- "A" - "B" Ports 1-1/16-12 UN
- Drain Port 1-1/16-12
- Side Ports
- Rear Ports

### Control Systems

- 12V Electrical Control
- 24V Electrical Control
- Remote Hydraulic Servo-controls

46/50/65

49



## GENERAL INFORMATION

### Rotary Actuators

Young Powertech Rotary actuators are of the highest quality and performance. They have been applied in many applications all over the world for many years and now available from our USA facility.

ZERO leakage PTFE seals are used in all units to insure highest performance and long trouble free life.

The ARP series is built with large bearing capable of radial, axial and moment required in heavy duty application without the need of external bearings.

The shaft can be machined with a through hole for other functions.

Custom made units are available to OEM to meet specific requirements.

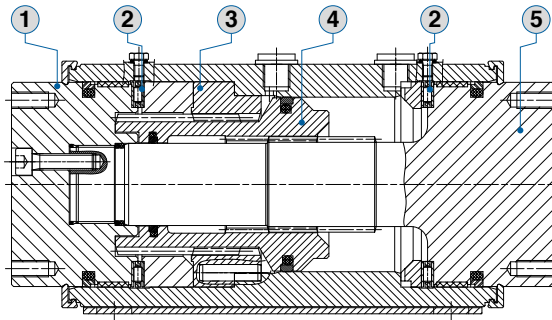

1	Threaded End Flange
2	Thrust Ring
3	Spiral Gear Ring
4	Spiral Gear Piston
5	Splined Shaft



Type	Application	Max Output Torque Nm	Straddle Moment Nm	Cantilever Moment Nm	Thrust Force N	Max Radial Load N
YARM 45	Agricultural machines	880	-	-	-	-
YARL 10	Agricultural machines	178	1000	-	4000	2000
YARF 53	Agricultural machines	880	-	-	-	-
YARL 1000	Control valves	21590	-	-	-	-
YARC 130	Davits	2953	-	26000	24000	12000
YARL 1000	Davits	21590	-	20000	60000	65000
YARC 165	Davits	3900	-	26000	24000	12000
YARC 850	Davits	18840	-	26000	12000	12000
YARC 55	Gateways	1200	-	6900	12000	6000
YARP 265	Gateways	5870	18000	6500	40000	40000
YARP 510	Gateways	11350	32000	9000	65000	65000
YARC 85	Horizontal Sliding Tops	1900	-	5000	5000	6000
YARM 60	Mining Equipments	1293	-	1400	14000	4000
YARM 30/F	Mining Equipments	657	-	-	14000	4000
YARMD 170	Multifunctional Platforms	3667	-	-	12000	40000
YARMD 300	Multifunctional Platforms	6000	-	-	8000	28000
YARMD 600	Multifunctional Platforms	12000	-	-	12000	40000
YARMD 750	Multifunctional Platforms	17300	-	-	18000	50000
YARMD 1300	Multifunctional Platforms	28577	-	-	24000	80000
YARP 25	Platform	525	2500	1400	4000	12500
YARP 40	Platform	925	4800	2400	6000	20000
YARP 80	Platform	1744	12000	4000	8000	30000
YARP 140	Platform	3136	18000	6500	12000	40000
YARP 200	Platform	3980	18000	6500	40000	40000
YARP 35	Platform	773	-	2000	6000	4000
YARP 350	Platform	7620	32000	9000	65000	65000
YARP 50	Platform	1173	-	3000	6500	6500
YARP 500	Platform	11682	42000	11000	80000	80000
YARC 35	Platform	800	3800	2300	20000	20000
YARP 750	Platform	14335	42000	11000	80000	80000
YARF 210/R	Ports of Stern	4576	-	-	-	-
YARM 140	Ports of Stern	3056	-	-	30000	16000
YARL 600	Ports of Stern	12977	-	-	-	-
YARM 60	Urban Cleaning Machines	1350	-	-	19000	7500
YARM 115	Urban Cleaning Machines	2555	-	-	25000	12000



## YA10V SERIES 31

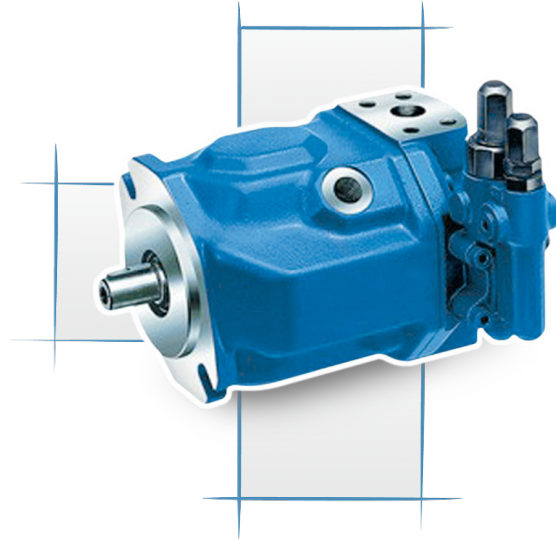

### Main Features

- Variable displacement axial piston pump
- SAE or ISO mounting flanges
- Continuous pressure to 4000 PSI
- High efficiency
- Low noise
- Wide range of controls
- Through drive for multi-circuit systems

### TECHNICAL DATA

Size				28	45	71	100	140	
Displacement			$V_{g \max}$	mL/r	28	45	71	100	140
Max.Speed <sup>(1)</sup>		at $V_{g \max}$	$n_{o \max}$	rpm	3000	2600	2200	2000	1800
Max.permitted Speed (limit speed) with increased input pressure		$P_{\text{abs}}$ bzw. $V_g < V_{g \max}$	$n_{o \max}$	rpm	3600	3100	2600	2400	2100
Max Flow		at $n_{o \max}$	$Q_{vo \max}$	L/min	84	117	156	200	252
		at $n_E=1500 \text{ min}^{-1}$		L/min	42	68	107	150	210
Max. Power ( $\Delta P= 28 \text{ MPa}$ )		at $n_{o \max}$	$P_{o \max}$	Kw	39	55	73	93	118
		at $n_E=1500 \text{ min}^{-1}$		Kw	20	32	50	70	98
Max. Torque ( $\Delta P= 28 \text{ MPa}$ )		at $V_{g \max}$	$T_{\max}$	Nm	125	200	316	445	623
Torque ( $\Delta P= 10 \text{ MPa}$ )		at $V_{g \max}$	T	Nm	45	72	113	159	223
Moment of Inertia about drive axis			J	kgm <sup>2</sup>	0.0017	0.0033	0.0083	0.0167	0.0242
Case Volume				L	0.7	1.0	1.6	2.2	3.0
Weight (without fluid)			m	Kg	15	12	33	45	60

## YHA2FM SERIES

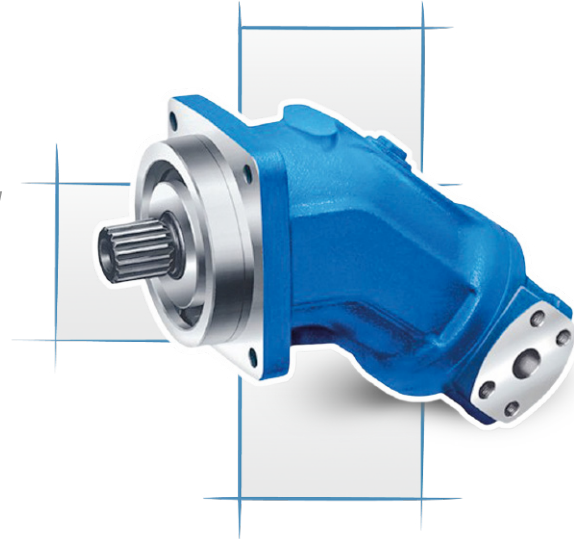

### Main Features

Sizes **80 - 90 cc**  
 Nominal pressure **5000 PSI**  
 Peak pressure **6000 PSI**

- Fixed displacement motor YHA2FM of axial piston, bent axis design, suitable for hydrostatic drives in open and closed circuits
- Use in mobile and industrial applications
- High power density
- Compact design
- High overall efficiency

### TECHNICAL DATA

Size			80	90	
Displacement	$V_g$	mL/r	80.4	90.0	
Max.Speed <sup>(1)</sup>	$n_{max}$	min <sup>-1</sup>	4500	4500	
	$n_{max\ limit}$	min <sup>-1</sup>	5000	5000	
Max flow	$q_{v\ max}$	L/min	360	405	
Torque Constants	$T_k$	Nm/MPa	12.7	17.0	
Torque	at $\Delta P= 35\ MPa$	T	Nm	445	501
	at $\Delta P= 40\ MPa$	T	Nm	508	572
Torque ( $\Delta P= 10\ MPa$ )		L	0.55	0.55	
Mass Moment of Inertia around output shaft	J	kgm <sup>2</sup>	0.0072	0.0072	
Weight (without fluid)		Kg	23	23	

YHA2FM



*In-line Helical*



*Shaft Mounting Gearboxes*



*Parallel and Shaft Mounting Gearboxes*



*Bevel Helical Gearboxes*



*Universal Bevel Helical Gearboxes*



*Parallel Gearboxes*



*High Torque Bevel Helical Gearboxes*



*Quick Locking*



*Cooling Tower Gearboxes*



*Bucket Elevator Gearboxes*



*Lifting Gearboxes*



*Extruder Gearboxes*



*Mixer Gearboxes*



*Skew Bevel Helical Gearboxes*



*Worm Gearboxes and Torque limiters*



*Universal Worm Gearboxes*



*Double Worm Gearboxes*



*Helical Worm Gearboxes*



*Universal Worm Gearboxes*



*Mechanical Speed Variator*



*Right Angles*



*Electric Motors and Brake Electric Motors*



*Electronic Speed Variators*



# STM team MECHANICAL PRODUCTS



*Inverters*



*Planetary Gearboxes*



*Slewing Planetary Gearboxes*



*Large Size Planetary Gears*



*700 Series Hyd-Drive*



*900 Series Planetary*



*Shaft Mounted*



*Speed Increaseers*



*Gear Reducers*



*Overhung Load Adaptors*



*Electromagnetic Clutches*



*Mechanical Clutches*



*Accessories and Chain Couplings*



*Wheel and Track Drives*

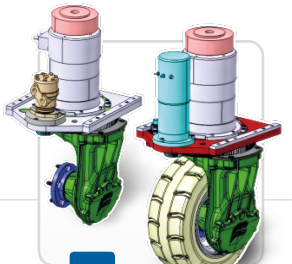

*Vertical Electric Drives*

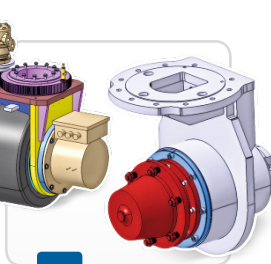

*Horizontal Electric Drives*

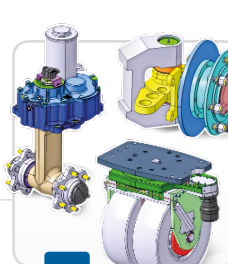

*Non-Driven Twin Steering*

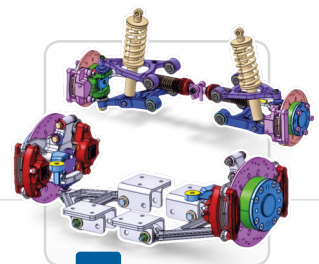

*Electrically Driven Axles*

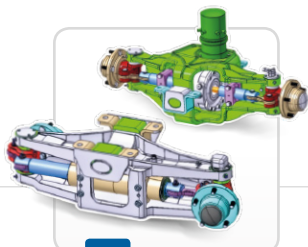

*Full Steering Axles*

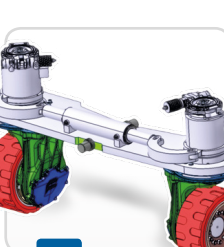

*Special Products*



*Slewing Bearings and Drives*



## **LIMITED ONE YEAR WARRANTY**

If the products fails to function within one (1) year after the date of its original shipment, or invoice date whichever occurs first, due to a defect in the materials or workmanship, Young Powertech (YPT) will remedy the defect without charge to the consumer purchaser. The foregoing limited warranty does not cover failure to function caused by damage to the product while in your possession, improper installation, unreasonable use or abuse of the product, failure to provide or use of improper maintenance, failure to follow written installation and instructions.

THE REMEDIES PROVIDED IN THE ABOVE EXPRESS LIMITED WARRANTY ARE THE SOLE AND EXCLUSIVE REMEDIES AVAILABLE TO YOU. NO OTHER EXPRESS WARRANTIES ARE MADE. ALL IMPLIED WARRANTIES, INCLUDING BUT NOT LIMITED TO ANY IMPLIED WARRANTY OF MERCHANTABILITY OR FITNESS FOR A PARTICULAR PURPOSE OR USE, ARE LIMITED IN DURATION AS SET FORTH ABOVE. IN NO EVENT SHALL YPT BE LIABLE FOR ANY INCIDENTAL OR CONSEQUENTIAL DAMAGES.

Some states do not allow limitations on how long an implied warranty lasts or do not allow the exclusion or limitation of incidental or consequential damages, so the above limitations or exclusions may not apply to you. This warranty gives you specific legal rights and you may also have other rights which vary from state to state. The consumer-purchaser must maintain proof of purchase and shipment date of the product to prove the date of purchase and shipment in the unlikely event of a warranty claim.

In order to obtain a return authorization number you must contact Young Powertech Inc at **(610) 558-0760** prior to shipping. The customer will be required to ship only the defective parts, freight pre-paid to :

**Young Powertech Inc**  
**3060 Plaza Drive • Garnet Valley PA 19060 • Fax: (610) 558-0762**  
**e-mail: [info@youngpowertech.com](mailto:info@youngpowertech.com)**

Young Powertech Inc, will repair or replace any part found defective and return the unit prepaid by ground shipment to the customer.

In the event that the unit is not found to have a defect the customer will be charged an inspection fee and the unit will be returned freight collect to the customer.



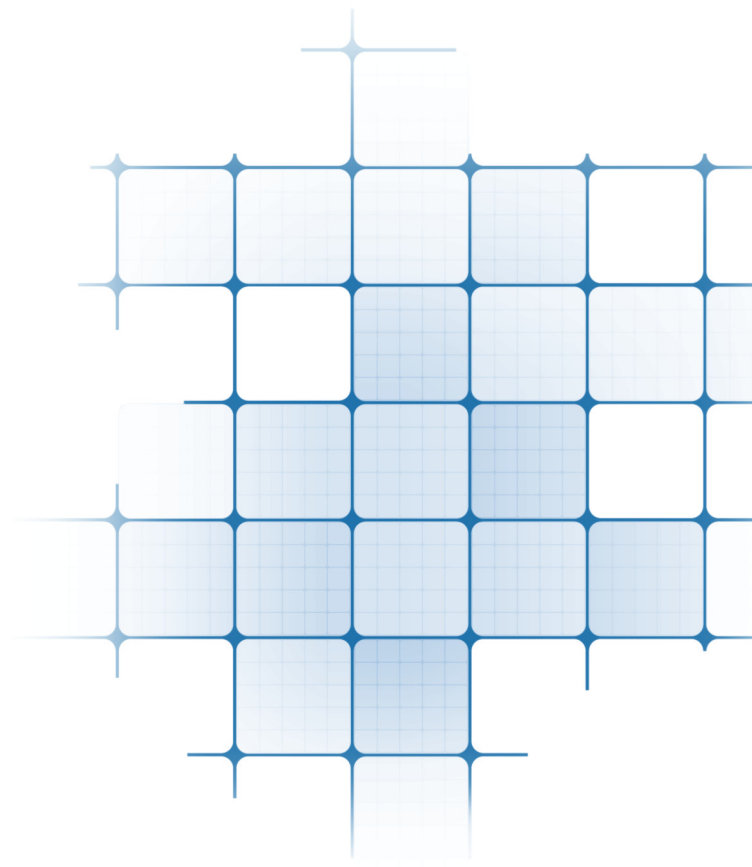



Young Powertech Inc  
3060 Plaza Drive  
Garnet Valley PA 19060  
Tel: (610) 558-0760  
Fax: (610) 558-0762  
e-mail: [info@youngpowertech.com](mailto:info@youngpowertech.com)  
[www.youngpowertech.com](http://www.youngpowertech.com)