



YSTFC (HD)
series



YSTFD (HD)
series



YITM series

Radial Piston Motors



STF

Ultra modern manufacturing facility
were the best team work
in harmony to produce
very high quality hydraulic motors



THE PRODUCTS

For many years our company has been manufacturing Radial Piston Motor for our own use and market. Now, after many years of improvements, with the use of new technology, materials, machine tools we have achieved a quality equal or superior to our competitors. We are now offering our products to the open market.

YSTFC (HD) SERIES



This series of motor is based on the “hydraulically balanced piston rod” technology. Offering high efficiency, low noise, constant torque and long life even in the most severe applications

page 2

YSTFD (HD) SERIES



This is a “two-speed” variation of the YSTFC. This series is based on the variable crankshaft which permits the motor to go from maximum displacement to zero during motion with a very smooth and constant torque output. By reducing the displacement and increasing the speed, we can meet many application requirements.

page 27

YITM SERIES



This series with the bearing between the piston and crank permits even higher torque efficiency and smooth operation. With its “hydraulically balanced’ Distributor, this series will deliver a very high volumetric efficiency.

page 49

YSTFC CONTENTS

YSTFC

General Description	page 3
Performance Data	page 3
Installation Data	page 4
Technical Specification	page 5
YSTFC (HD) 080 Series	page 6
YSTFC (HD) 100 Series	page 8
YSTFC (HD) 125 Series	page 10
YSTFC (HD) 200 Series	page 14
YSTFC (HD) 270 Series	page 18
YSTFC (HD) 325 Series	page 20
YSTFC (HD) 400 Series	page 22
Ordering Code	page 25



GENERAL DESCRIPTION

YSTFC (HD)

The YSTFC Series consists of 7 sizes with 24 different displacements ranging from 61 to 415 Cu.In/Rev (1000-6800 cc) and torque outputs from 2392 Lb-Ft (3243 Nm) to 15,427 Lb-Ft (20,916 Nm).

The exceptionally well built and perfected design incorporates many of the most advanced technologies developed over the years to achieve the best efficiency, smooth running torque and speed.

Our complete line of motors are manufactured to be interchangeable with other competitors and can be applied to many application.

The YSTFC-HD series is an enhanced "**HEAVY DUTY**" Series for the most arduous application.

A dual speed or variable speed series, (YSTFD) is also available.

PERFORMANCE DATA

YSTFC (HD)

All performance data is based on mineral oil at 50 cSt (232SSU). If motors are used with other fluid or under different condition, performance will change. Also motor return line at zero pressure.

RATING DEFINITION:

CONTINUOUS: For continuous duty the motor must run at "rated" speed and pressure

INTERMITTENT: Operation within this range is based on motors running at not more than 15% of the time and for period of no more than 5 minutes.

MAXIMUM: Operating without exceeding the max power and RPM for more than one minute periods.

For Fire Resistant fluid, we recommend running the motors at 50% of rated speed, torque, and pressure.

YSTFC (HD)

INSTALLATION INSTRUCTIONS

GENERAL INFORMATION:

MOUNTING SURFACE: The mounting surface should be sufficiently strong and flat to prevent movement between the motor shaft and mating part.
 When motor is solidly coupled to a shaft with its own bearings, the concentricity must be within .012MM (0.0045:)"

MOUNTING POSITION: Motor housing must be filled with oil before start up of the motor. Motor mounting must be such where the drain line of the motor is below the lowest possible level of the tank to prevent draining the housing. If motor is above such line, it must have valve to prevent oil siphoning. Housing pressure must not exceed 3.5 BAR (50 PSI). In application where the drain line is long or back pressure from other components can exceed desired pressure, a relief valve should be installed. High pressure seal for 10 BAR (1450 psi) available upon request. See options list

HYDRAULIC FLUIDS: Depending on the application on the seal compounds, the motor can run with many different fluids

- Mineral Oil
- Water Glycols
- Phosphate ester
- HBS Water emulsion *
- HFA Water emulsion *

* Operating pressure must be reduced see instruction page:

TEMPERATURE LIMITS: Mineral oil Min. - 20C - -5 F
 Max. + 60C (175F)
 Water Emulsion Min. + 10C (50F)
 Max + 60C (140F)

OTHER RECOMMENDATIONS

- Hydraulic fluid should be kept at 10 Micron Filtration at all time.
- Additives like anti-oxidant, anti-foam, and demulsifying should be used.
- Additional EP anti-wear should always be used.
- Regular motors oils and transmission fluid not recommended.

BOOST PRESSURE: When operating the motor in application where the load can overrun the motor, a boost pressure must be maintained at all time to prevent cavitation.

TECHNICAL SPECIFICATONS

YSTFC (HD)

TYPE	Displacement				Pressure				Rated Torque		Unit Torque		Speed Range	Weight	
	nominal		theory		Rated pressure		Max Pressure								
	mL/r	in ³ /rev	mL/r	in ³ /rev	MPA	PSI	MPA	PSI	N.m	Lb/Ft	N.m/MPA	Lb/Ft/PSI	r/min	kg	lbs
YSTFC 080	1000	61	988	60.3	23	3335	29	4205	3243	2392	141	0.72	280	144	318
	1100	67	1088	66.4	23	3335	29	4205	3565	2629	155	0.79	280		
	1250	76.3	1237	75.5	23	3335	29	4205	3910	2884	170	0.86	280		
YSTFC 100	1400	85.43	1385	84.5	23	3335	29	4205	4554	3359	198	1.01	240	144	318
	1650	100.7	1630	99.5	23	3335	29	4205	5405	3987	235	1.20	240		
YSTFC 125	1400	85.4	1459	89	23	3335	29	4205	4807	3545	209	1.06	210	235	518
	1600	97.6	1621	98.8	23	3335	29	4205	5336	3936	232	1.18	210		
	1800	110	1864	113.7	21	3045	29	4205	5586	4120	266	1.35	160		
	2000	122	2027	123.7	21	3045	29	4205	6090	4492	290	1.48	160		
YSTFC 200	2400	146.5	2432	148.4	23	3335	29	4205	8188	6039	356	1.81	175	285	628
	2800	170.8	2757	168.2	23	3335	29	4205	9269	6836	403	2.05	150		
	3100	189	3080	188	21	3045	29	4205	9471	6985	451	2.29	135		
YSTFC 270	3300	201.4	3291	200.8	23	3335	29	4205	11063	8160	481	2.45	125	420	926
	3600	219.7	3575	218.2	23	3335	29	4205	12029	8872	523	2.66	125		
	4000	244.1	3973	242.4	21	3045	29	4205	12201	8999	581	2.96	100		
	4300	262.4	4313	263.2	21	3045	29	4205	13251	9773	631	3.21	100		
YSTFC 325	4500	274.6	4538	276.9	23	3335	29	4205	15272	11264	664	3.38	100	430	948
	5000	305.1	4992	304.6	23	3335	29	4205	16790	12384	730	3.71	100		
	5400	329.5	5310	324.1	21	3045	29	4205	16317	12035	777	3.95	100		
YSTFC 400	5500	335.6	5510	336.2	23	3335	29	4205	18538	13673	806	4.10	120	495	1090
	6000	366.1	5996	365.9	23	3335	29	4205	20171	14877	877	4.46	120		
	6500	396.7	6483	395.6	21	3045	29	4205	19908	14683	948	4.82	120		
	6800	415	6807	415.4	21	3045	29	4205	20916	15427	996	5.07	120		

YSTFC

YSTFC (HD) 080

YSTFC (HD) 080

TECHNICAL SPECIFICATIONS

TYPE	Displacement				Pressure				Rated Torque		Unit Torque		Speed Range	Weight	
	nominal		theory		Rated pressure		Max Pressure								
	mL/r	in ³ /rev	mL/r	in ³ /rev	MPa	PSI	MPa	PSI	N.m	Lb/Ft	N.m/MPa	Lb/Ft/PSI	r/min	kg	lbs
YSTFC 080	1000	61	988	60.3	23	3335	29	4205	3243	2392	141	0.72	280	144	318
	1100	67	1088	66.4	23	3335	29	4205	3565	2629	155	0.79	280		
	1250	76.3	1237	75.5	23	3335	29	4205	3910	2884	170	0.86	280		

YSTFC (HD) 080

INSTALLATION DIMENSIONS WITH FO1 DISTRIBUTOR

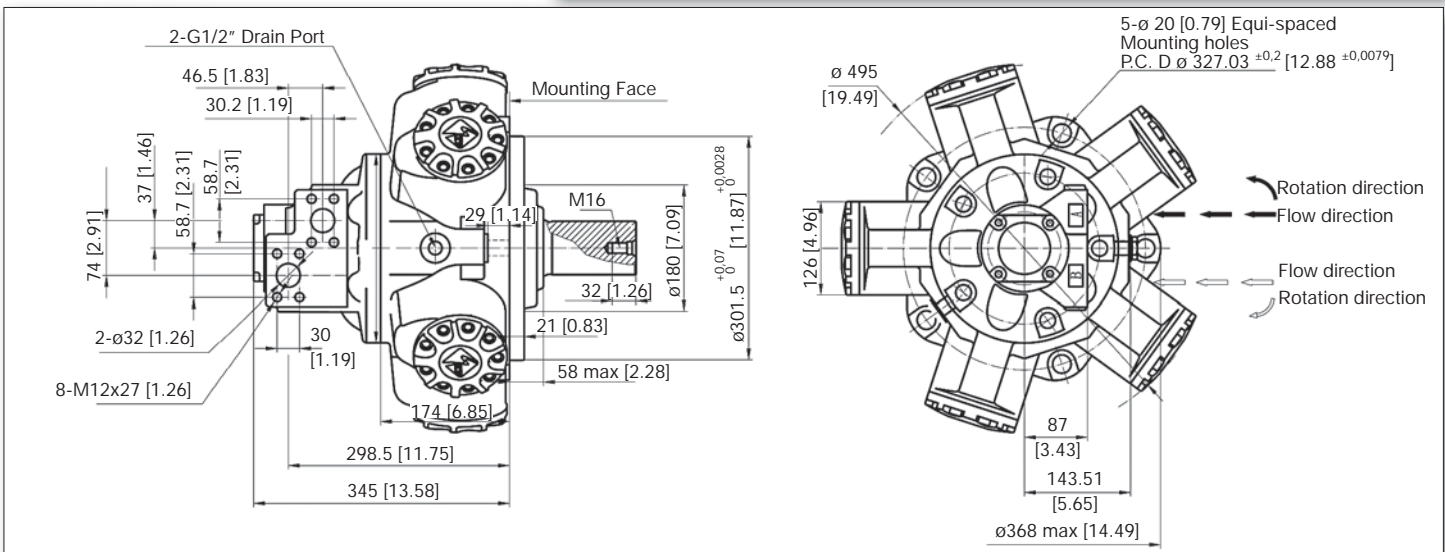

YSTFC 080-1250

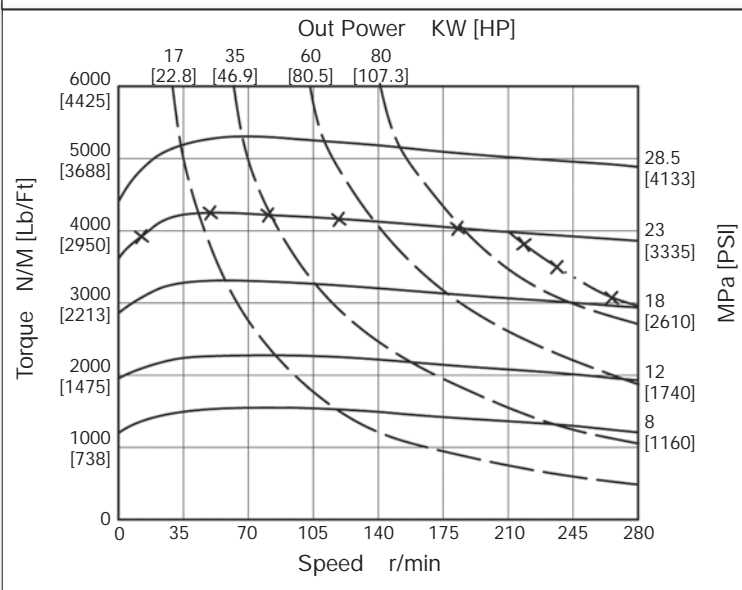

OUTPUT OPTIONS

YSTFC (HD) O80

P72 parallel key

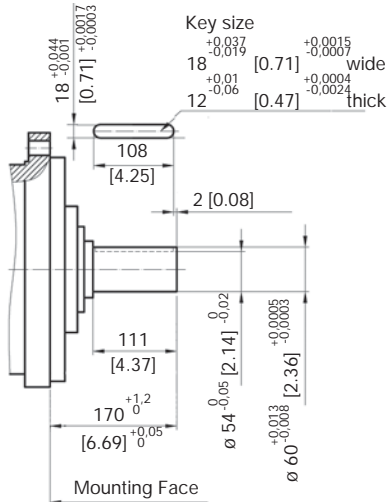

S71 BS 3550 spline

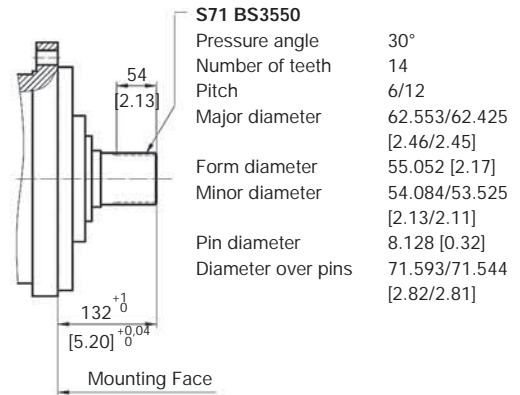

S72 DIN 5480 spline

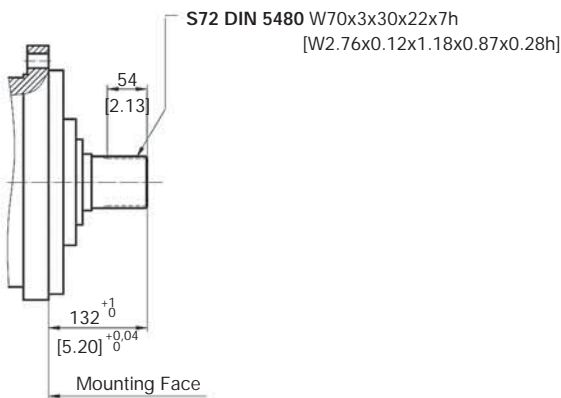

T71 tapered

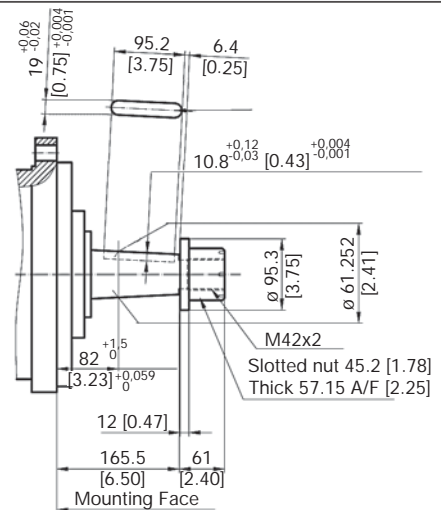

Q71 BS 3550 female splined

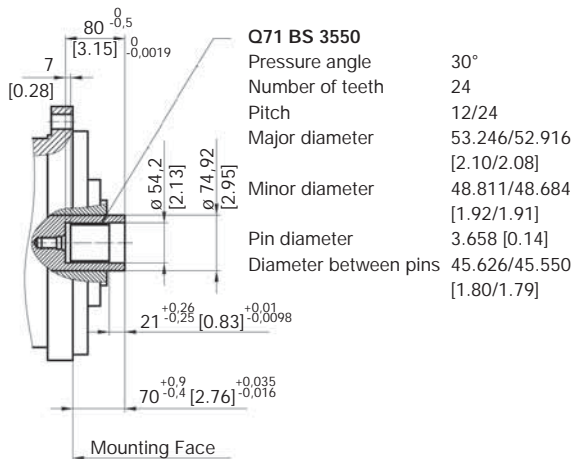

YSTFC (HD) 100

YSTFC (HD) 100

TECHNICAL SPECIFICATIONS

TYPE	Displacement				Pressure				Rated Torque		Unit Torque		Speed Range	Weight	
	nominal		theory		Rated pressure		Max Pressure								
	mL/r	in ³ /rev	mL/r	in ³ /rev	MPa	PSI	MPa	PSI	N.m	Lb/Ft	N.m/MPa	Lb/Ft/PSI	r/min	kg	lbs
YSTFC 100	1400	85.43	1385	84.5	23	3335	29	4205	4554	3359	198	1.01	240	144	318
	1650	100.7	1630	99.5	23	3335	29	4205	5405	3987	235	1.20	240		

YSTFC (HD) 100

INSTALLATION DIMENSIONS WITH FO1 DISTRIBUTOR

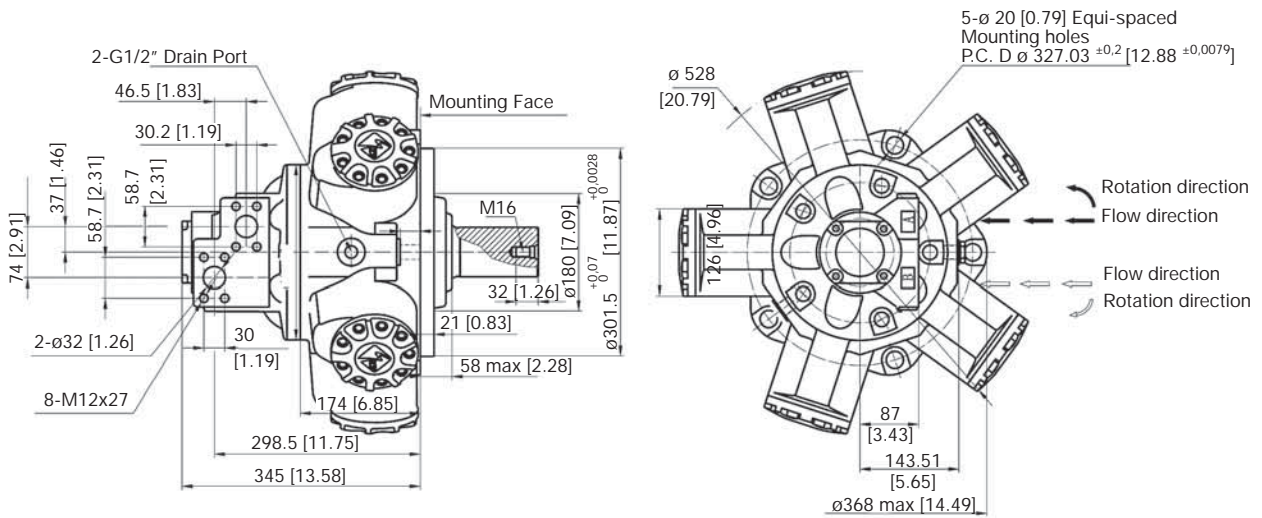

YSTFC 100-1650

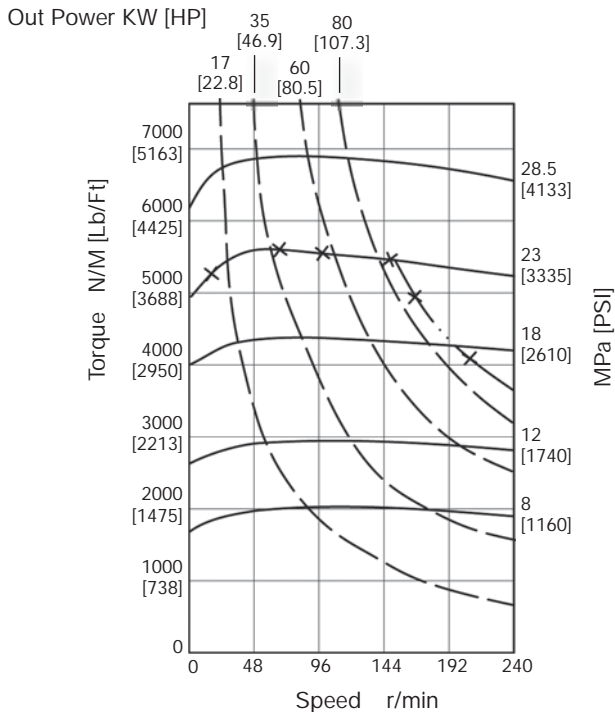

OUTPUT OPTIONS

YSTFC (HD) 100

P72 parallel key

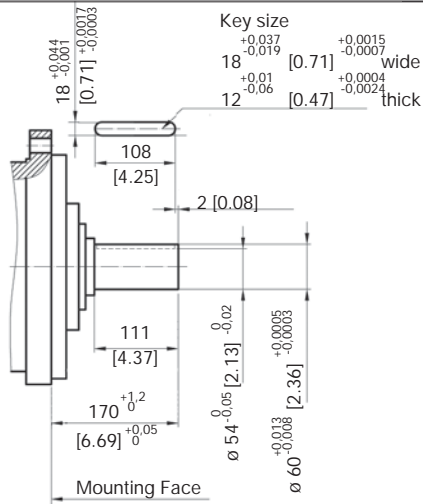

S71 BS 3550 spline

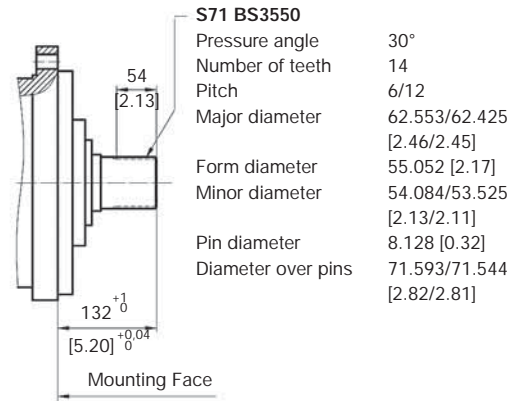

S72 DIN 5480 spline

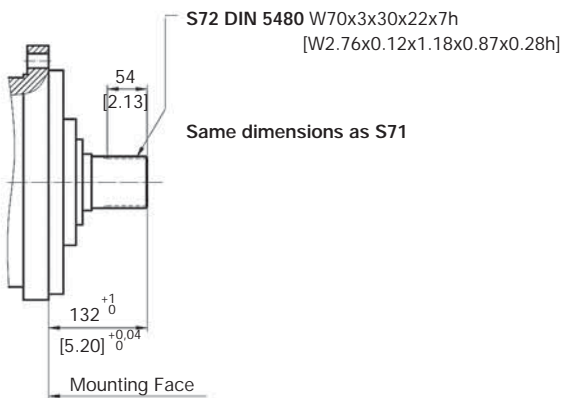

T71 tapered

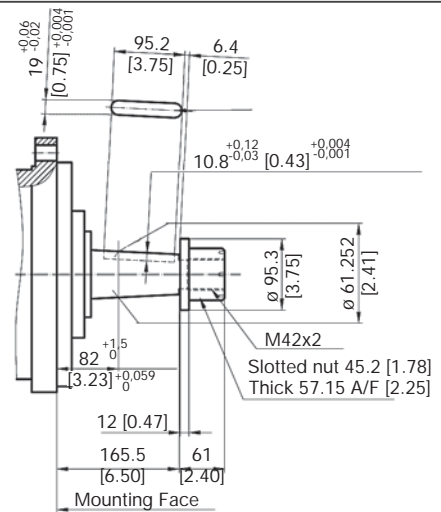

Q71 BS 3550 female spline

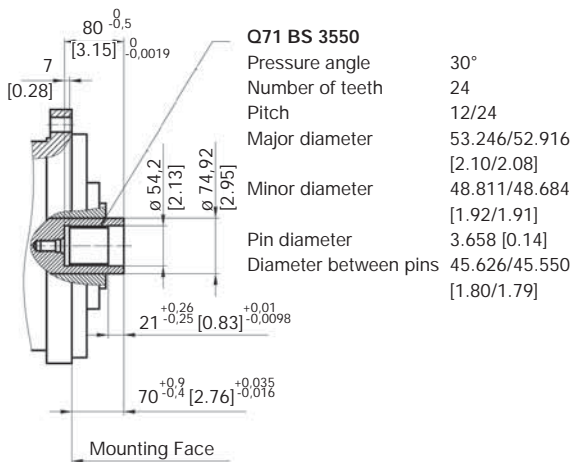

YSTFC (HD) 125

YSTFC (HD) 125

TECHNICAL SPECIFICATIONS

TYPE	Displacement				Pressure				Rated Torque		Unit Torque		Speed Range	Weight	
	nominal		theory		Rated pressure		Max Pressure								
	mL/r	in ³ /rev	mL/r	in ³ /rev	MPa	PSI	MPa	PSI	N.m	Lb/Ft	N.m/MPa	Lb/Ft/PSI	r/min	kg	lbs
YSTFC 125	1400	85.4	1459	89	23	3335	29	4205	4807	3545	209	1.06	210	235	518
	1600	97.6	1621	98.8	23	3335	29	4205	5336	3936	232	1.18	210		
	1800	110	1864	113.7	21	3045	29	4205	5586	4120	266	1.35	160		
	2000	122	2027	123.7	21	3045	29	4205	6090	4492	290	1.48	160		

YSTFC (HD) 125

INSTALLATION DIMENSIONS WITH FO2 DISTRIBUTOR

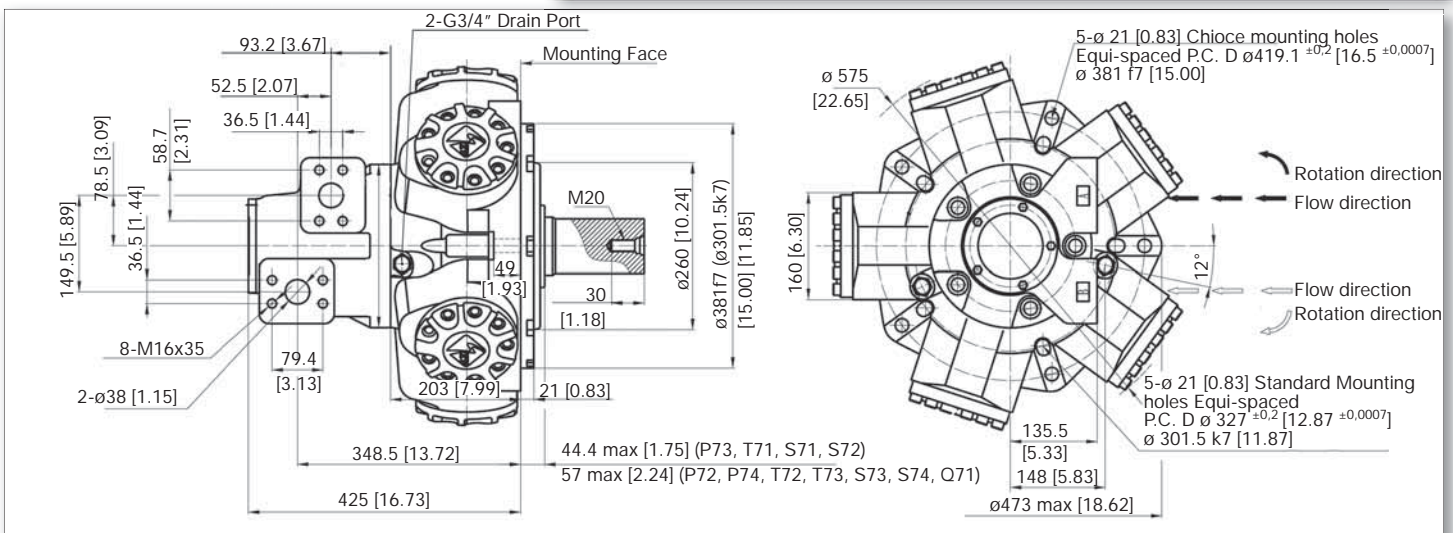

YSTFC 125-2000

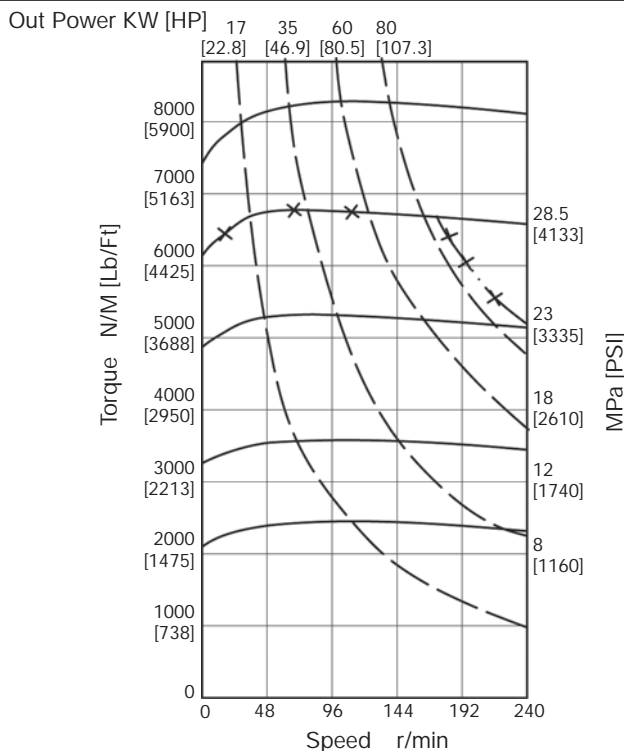

YSTFC (HD) 125 OUTPUT OPTIONS

Q71 BS 3550 female spline

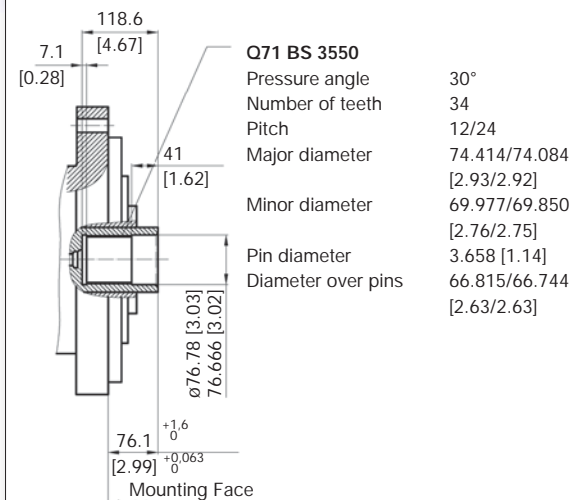

OUTPUT OPTIONS

YSTFC (HD) 125

P72 parallel key

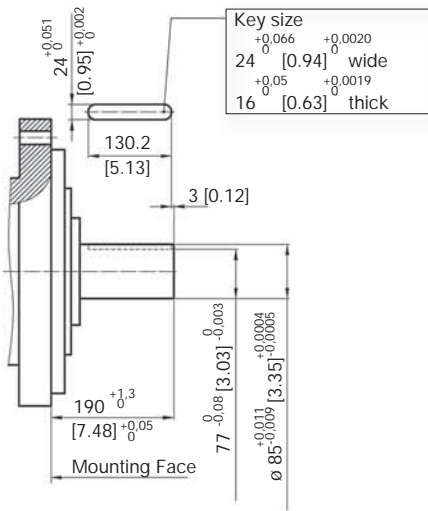

P74 long keyed shaft

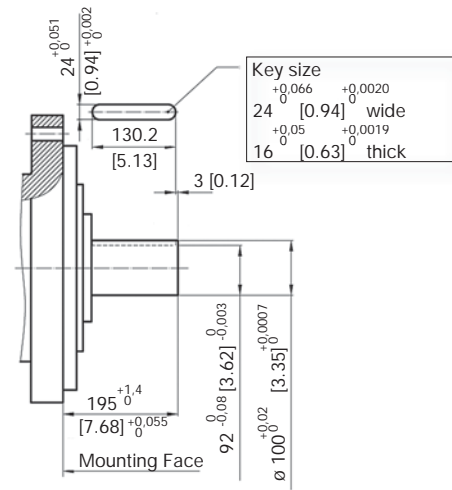

S73 BS 3550 spline

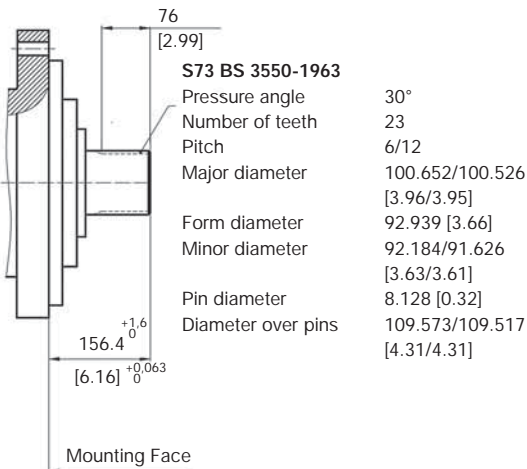

S74 DIN 5480 spline

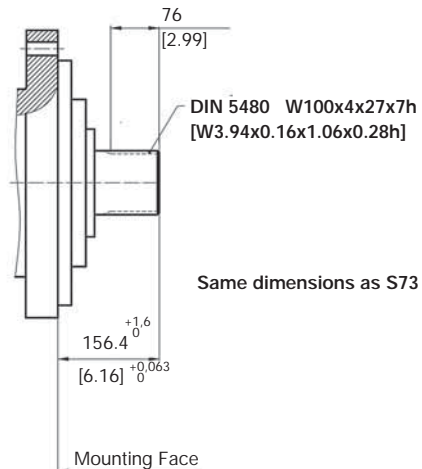

T72 short tapered

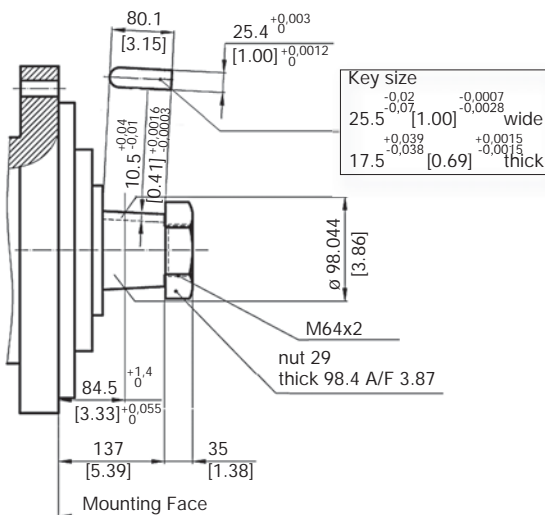

T73 long tapered

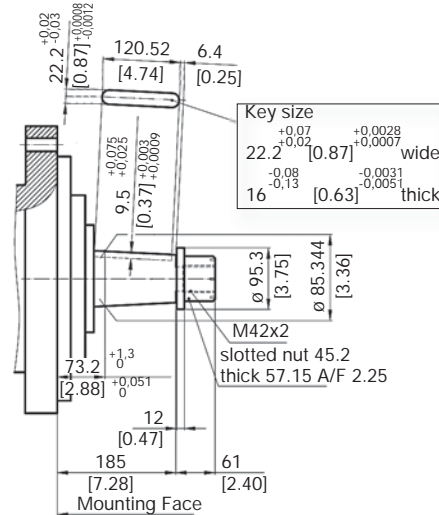

YSTFC 125

P73 parallel key

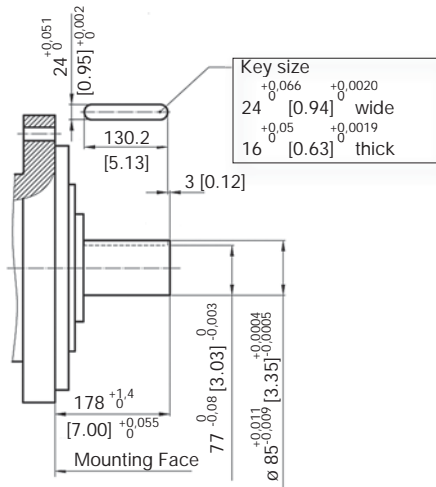

OUTPUT OPTIONS

S71 BS 3550 spline

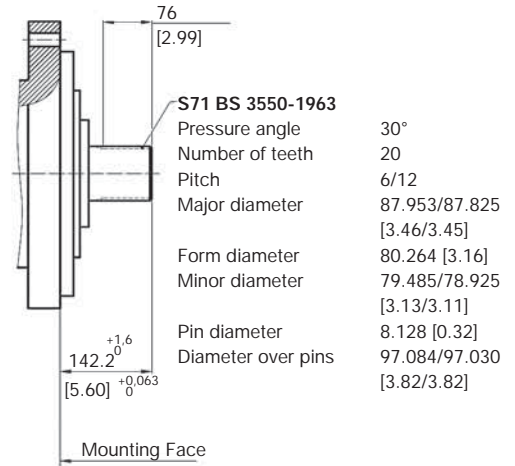

S72 DIN 5480 spline

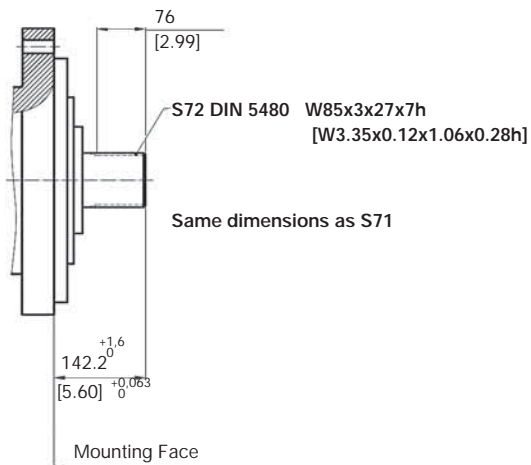

T71 tapered

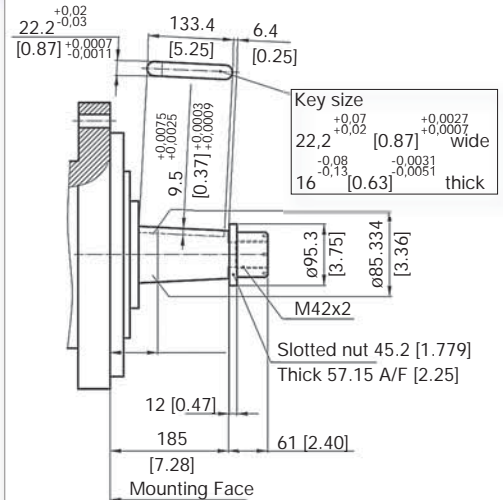

DISTRIBUTOR DATA

YSTFC (HD) 125

FO1 DISTRIBUTOR

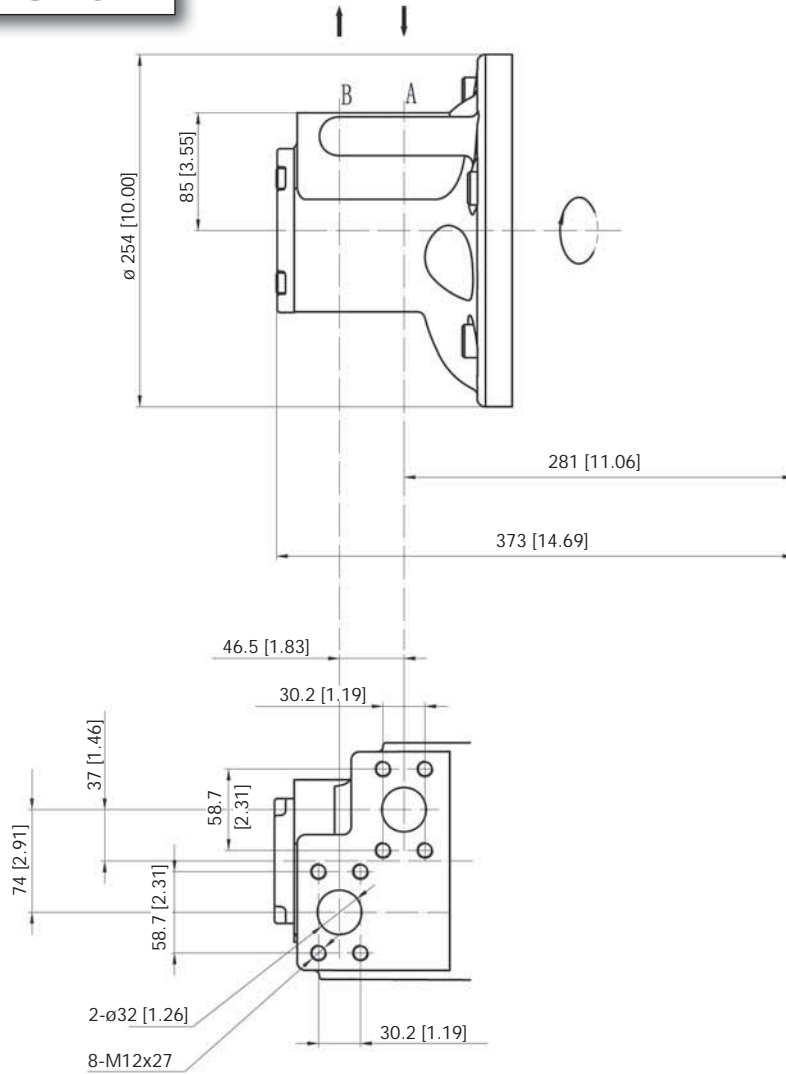

YSTFC

YSTFC (HD) 200

YSTFC (HD) 200

TECHNICAL SPECIFICATIONS

TYPE	Displacement				Pressure				Rated Torque		Unit Torque		Speed Range	Weight	
	nominal		theory		Rated pressure		Max Pressure								
	mL/r	in ³ /rev	mL/r	in ³ /rev	MPa	PSI	MPa	PSI	N.m	Lb/Ft	N.m/MPa	Lb/Ft/PSI	r/min	kg	lbs
YSTFC 200	2400	146.5	2432	148.4	23	3335	29	4205	8188	6039	356	1.81	175	285	628
	2800	170.8	2757	168.2	23	3335	29	4205	9269	6836	403	2.05	150		
	3100	189	3080	188	21	3045	29	4205	9471	6985	451	2.29	135		

YSTFC (HD) 200

INSTALLATION DIMENSIONS WITH FO2 DISTRIBUTOR

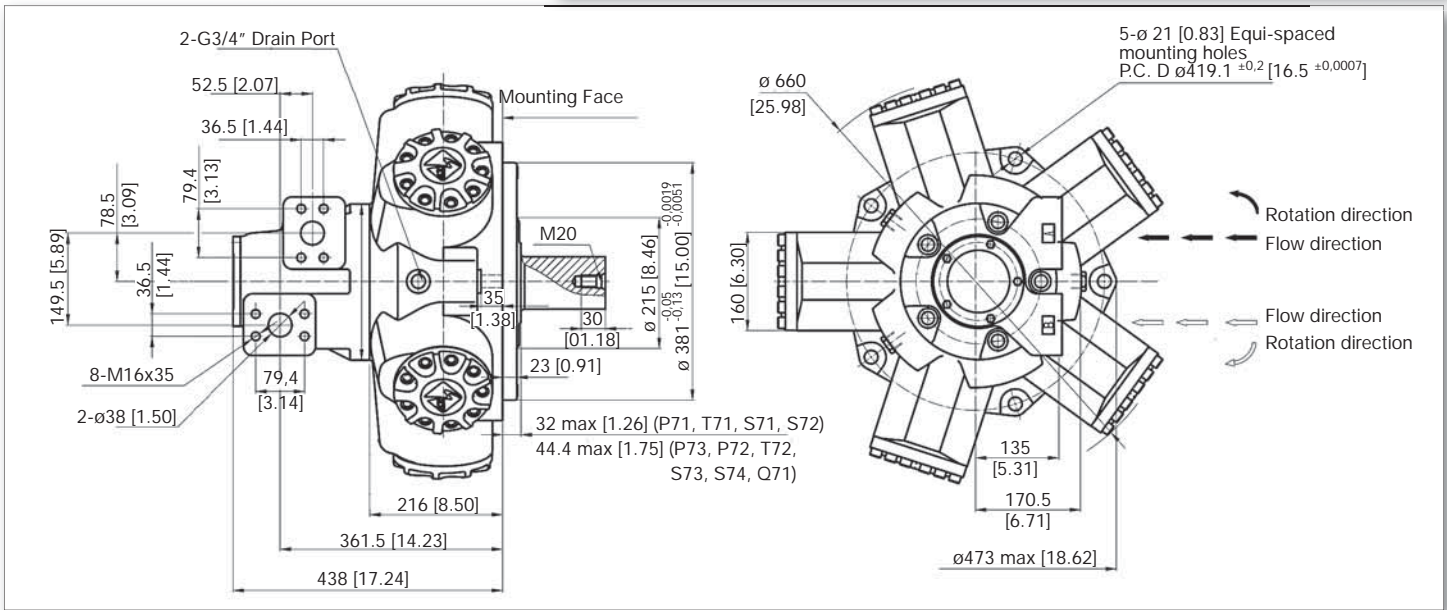

YSTFC 200-3100

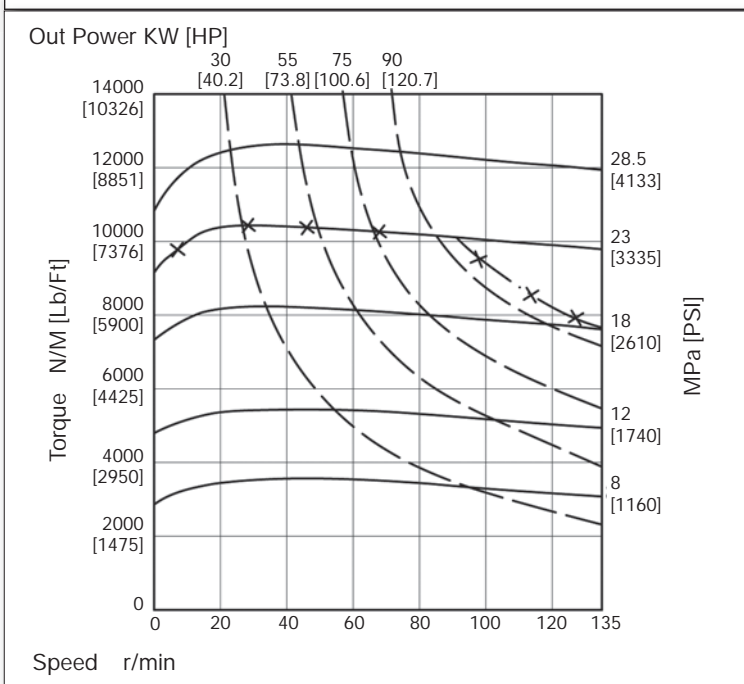

OUTPUT OPTIONS

YSTFC (HD) 200

P71 parallel key

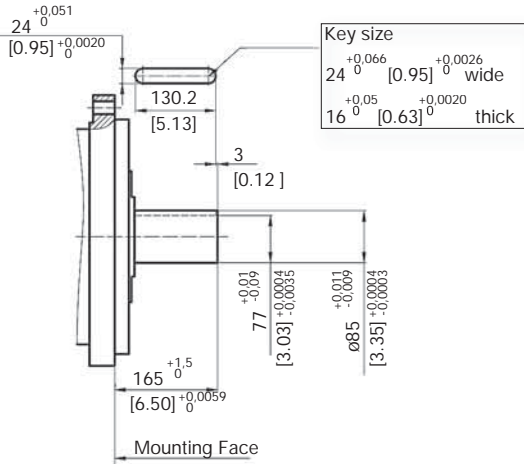

T71 tapered

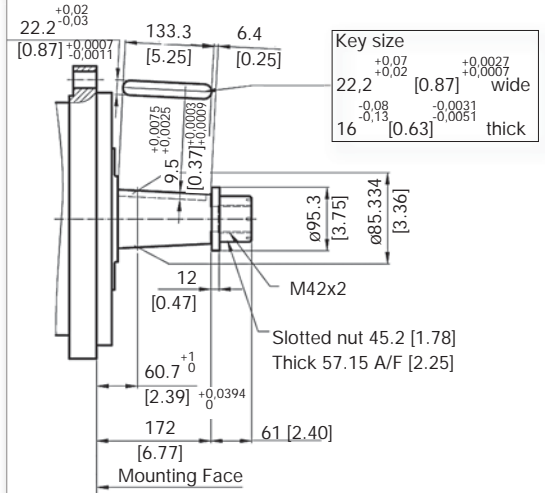

S71 BS 3550 spline

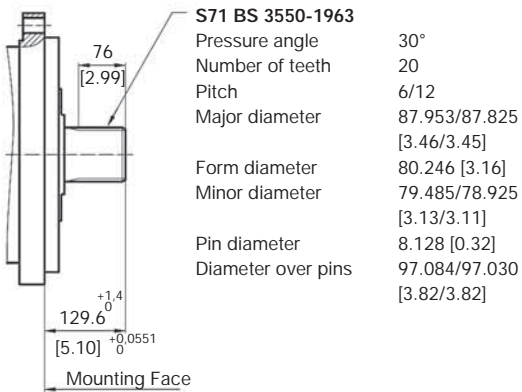

S72 DIN 5480 spline

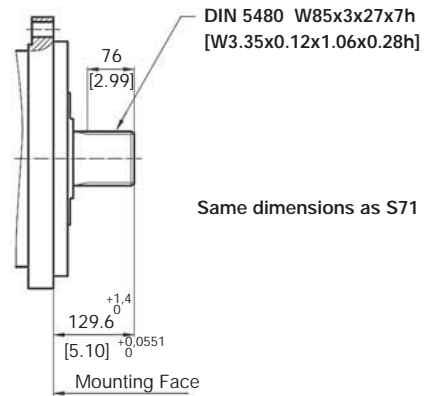

YSTFC

YSTFC (HD) 200

P73 parallel shaft

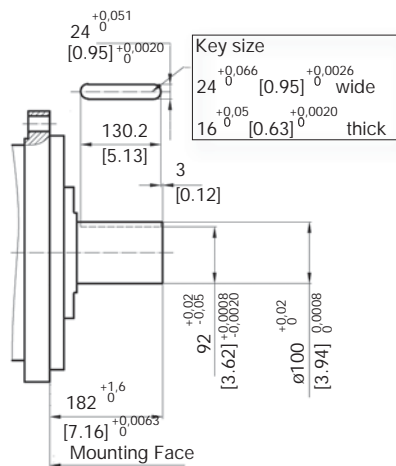

OUTPUT OPTIONS

S73 BS 3550 spline

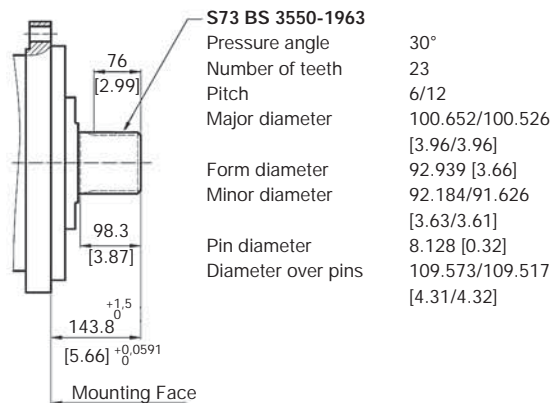

S74 DIN 5480 spline

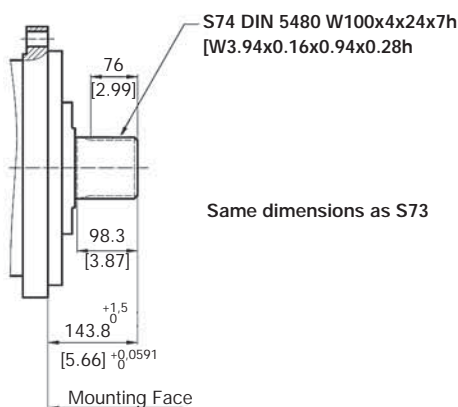

T72 short tapered

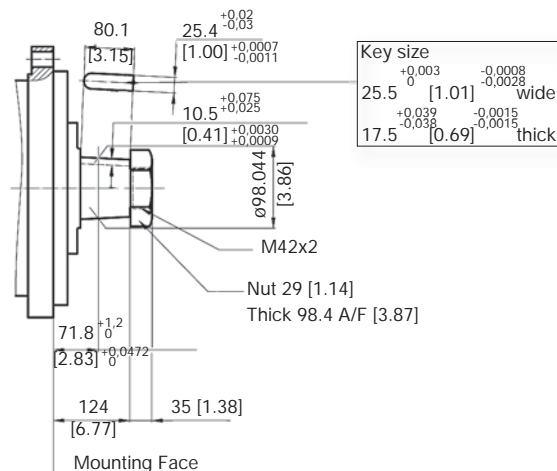

Q71 BS 3550 female spline

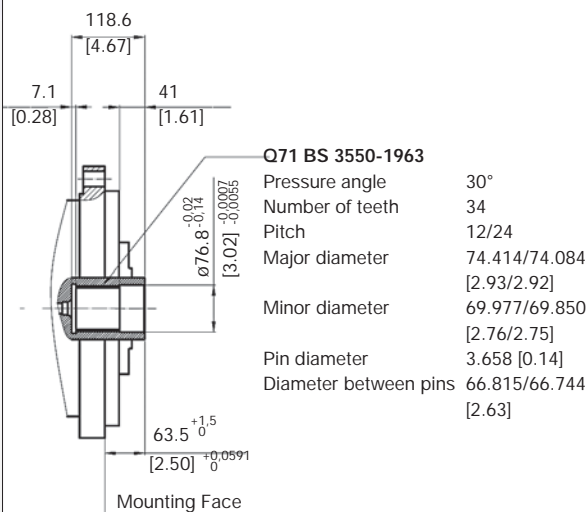

DISTRIBUTOR DATA

YSTFC (HD) 200

FO1 DISTRIBUTOR

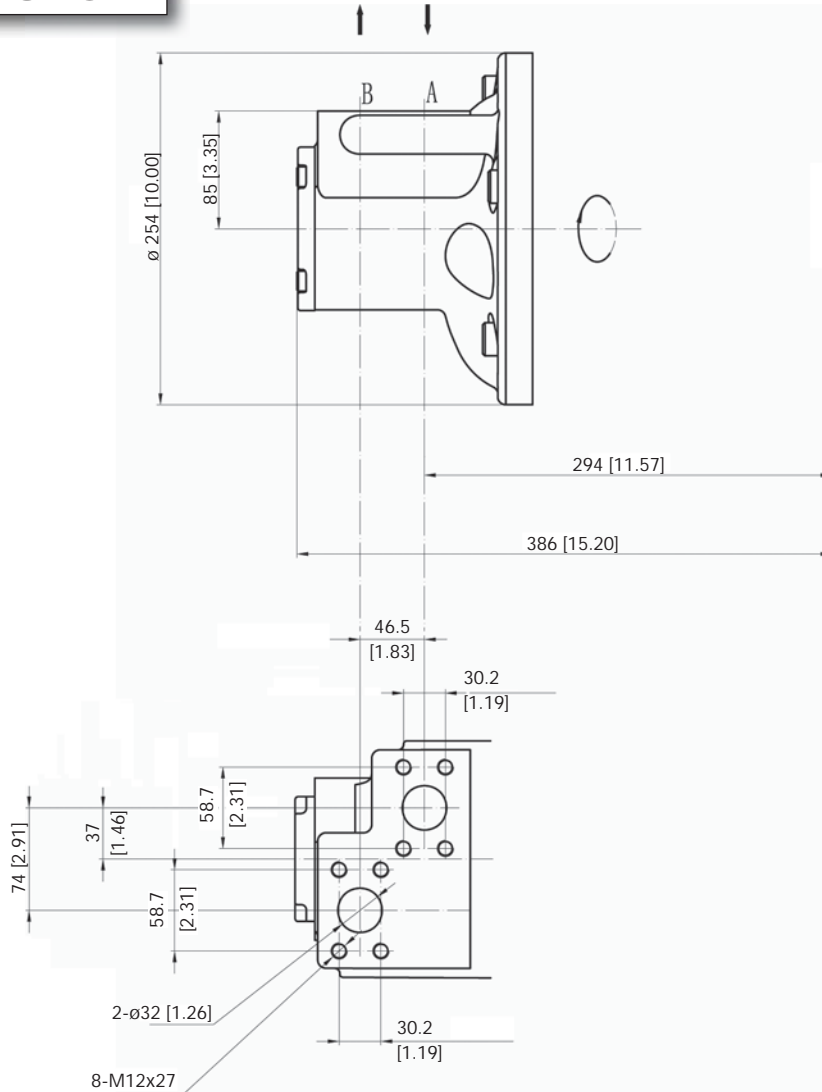

YSTFC

YSTFC (HD) 270

YSTFC (HD) 270

TECHNICAL SPECIFICATIONS

TYPE	Displacement				Pressure				Rated Torque		Unit Torque		Speed Range	Weight	
	nominal		theory		Rated pressure		Max Pressure		N.m	Lb/Ft	N.m/MPa	Lb/Ft/PSI	r/min	kg	lbs
	mL/r	in ³ /rev	mL/r	in ³ /rev	MPa	PSI	MPa	PSI							
YSTFC 270	3300	201.4	3291	200.8	23	3335	29	4205	11063	8160	481	2.45	125	420	926
	3600	219.7	3575	218.2	23	3335	29	4205	12029	8872	523	2.66	125		
	4000	244.1	3973	242.4	21	3045	29	4205	12201	8999	581	2.96	100		
	4300	263.2	4313	263.2	21	3045	29	4205	13251	9773	631	3.21	100		

YSTFC (HD) 270

INSTALLATION DIMENSIONS WITH FO3 DISTRIBUTOR

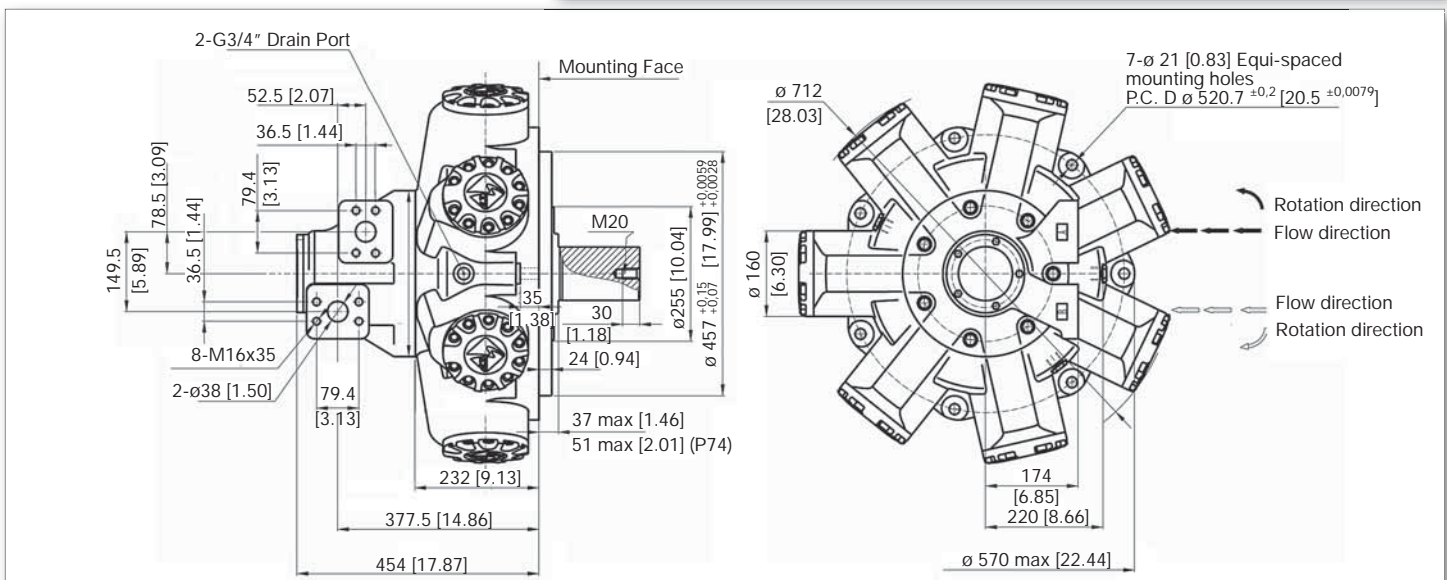

YSTFC 270-4300

Out Power KW [HP]

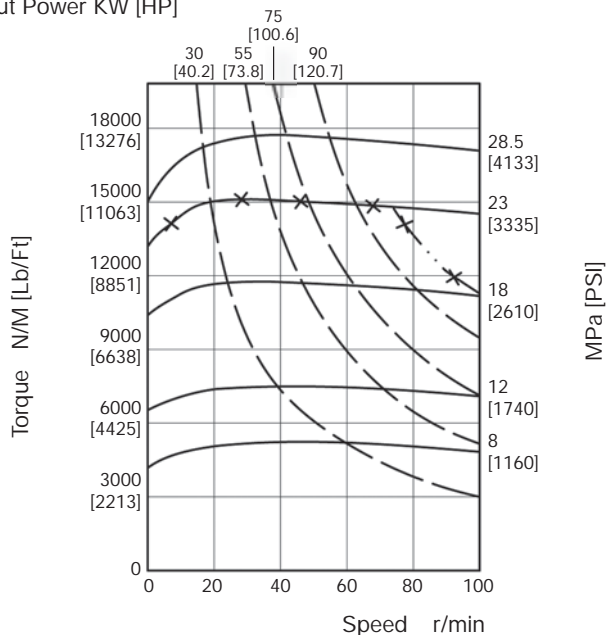

YSTFC (HD) 270 OUTPUT OPTIONS

P74 long keyed shaft

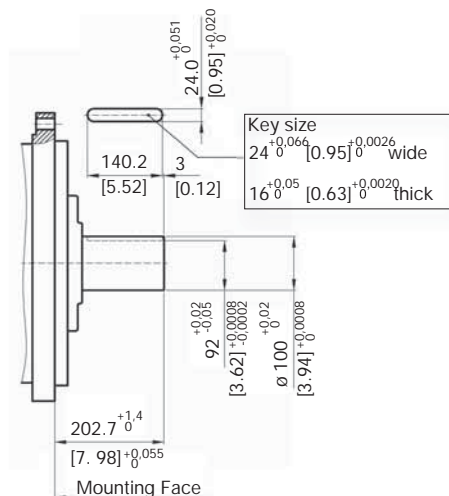

OUTPUT OPTIONS

P 73 parallel key

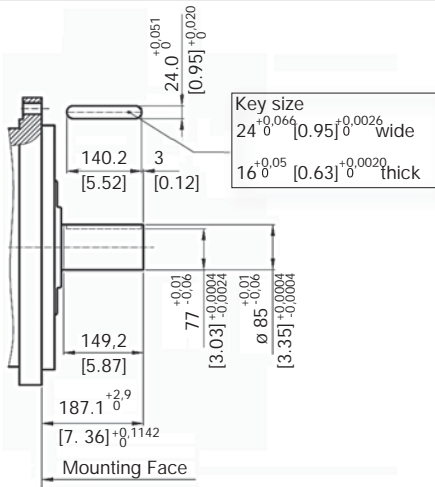

S 71 BS 3550 spline

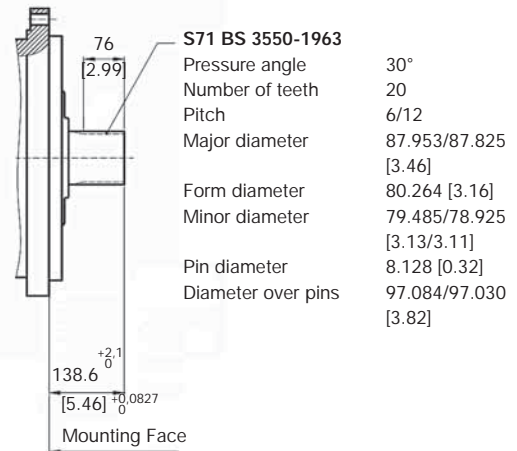

S 72 DIN 5480 spline

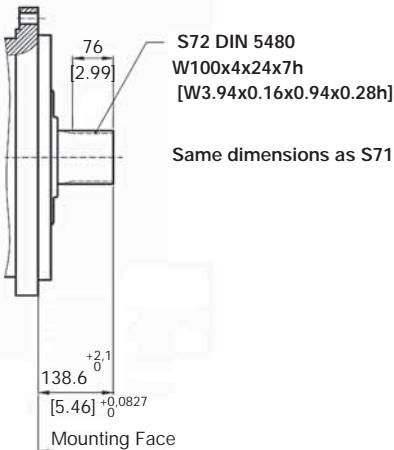

T 71 tapered

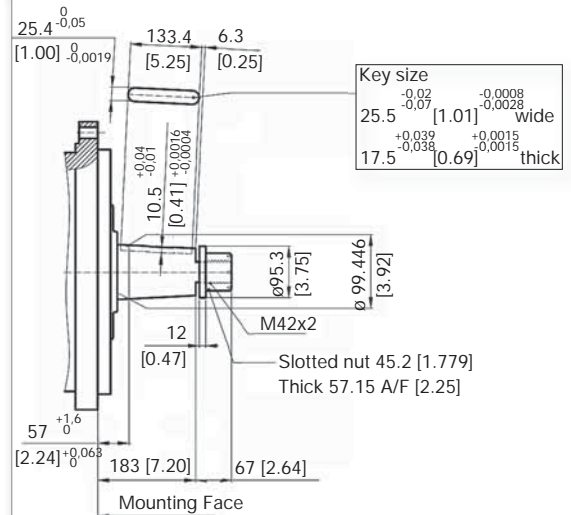

T 72 short tapered

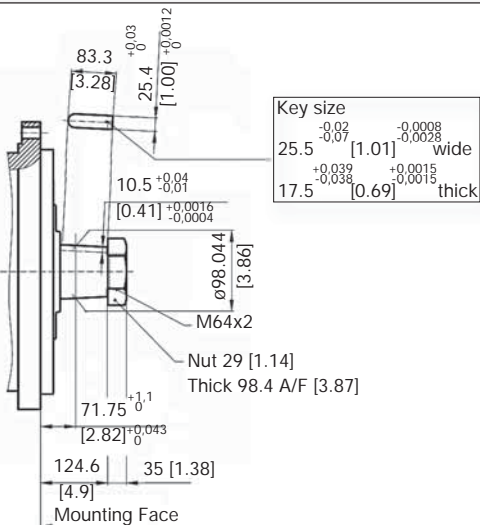

Q 72 BS 3550 female spline

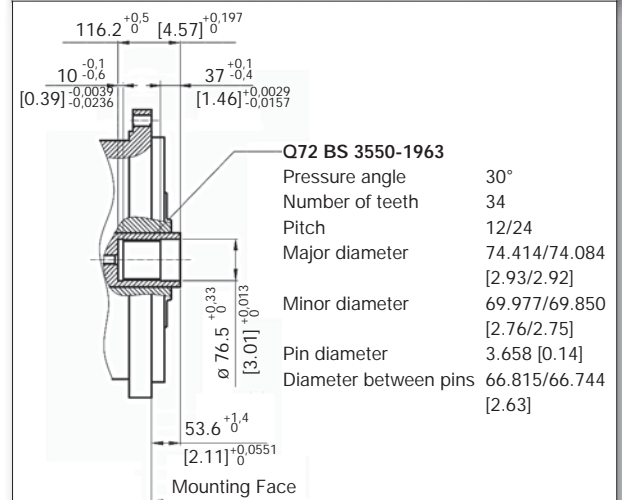

YSTFC (HD) 325

YSTFC (HD) 325

TECHNICAL SPECIFICATIONS

TYPE	Displacement				Pressure				Rated Torque		Unit Torque		Speed Range	Weight	
	nominal		theory		Rated pressure		Max Pressure								
	mL/r	in ³ /rev	mL/r	in ³ /rev	MPa	PSI	MPa	PSI	N.m	Lb/Ft	N.m/MPa	Lb/Ft/PSI	r/min	kg	lbs
YSTFC 325	4500	274.6	4538	276.9	23	3335	29	4205	15272	11264	664	3.38	100	430	948
	5000	305.1	4992	304.6	23	3335	29	4205	16790	12384	730	3.71	100		
	5400	329.5	5310	324.1	21	3045	29	4205	16317	12035	777	3.95	100		

YSTFC (HD) 325

INSTALLATION DIMENSIONS WITH FO2 DISTRIBUTOR

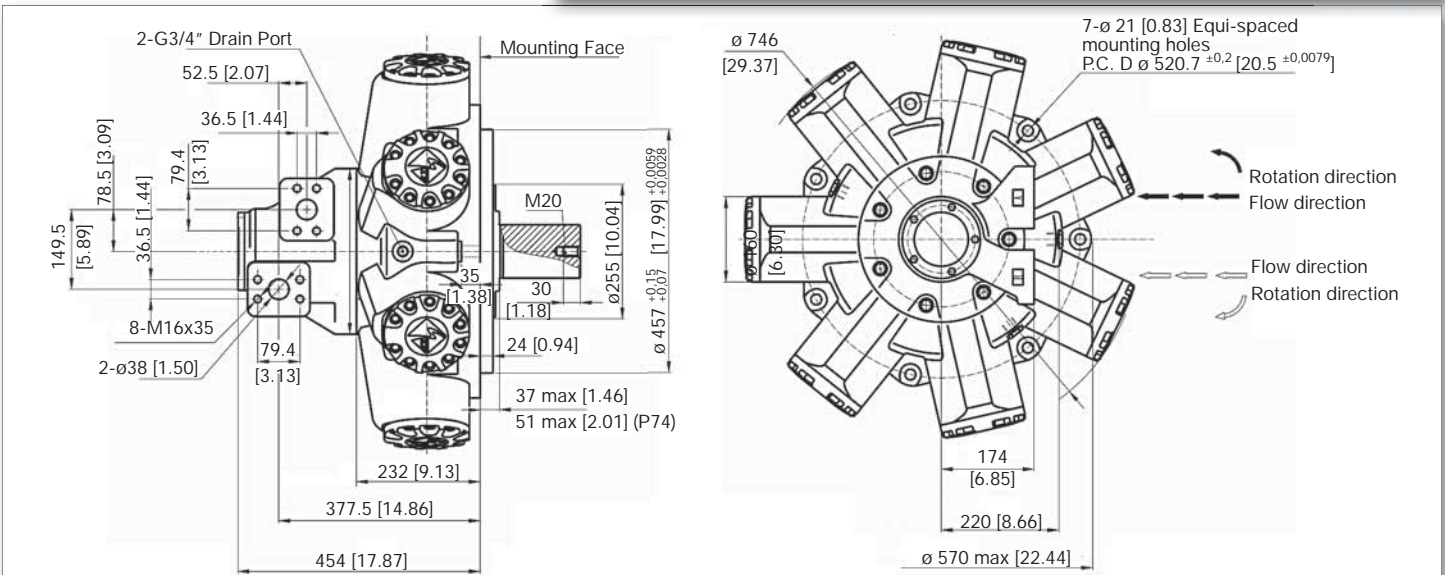

YSTFC325

Out Power KW [HP] 45 75 100
[60.3] [100.6] [134.1]

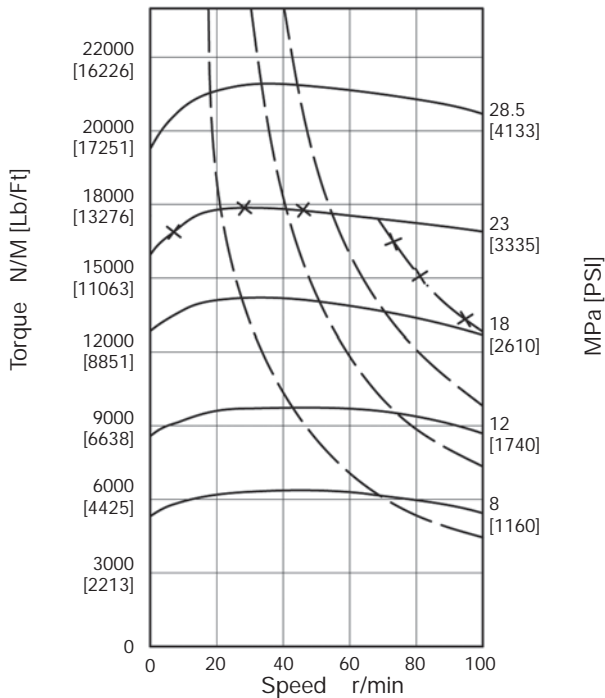

YSTFC (HD) 325 OUTPUT OPTIONS

P74 long keyed shaft

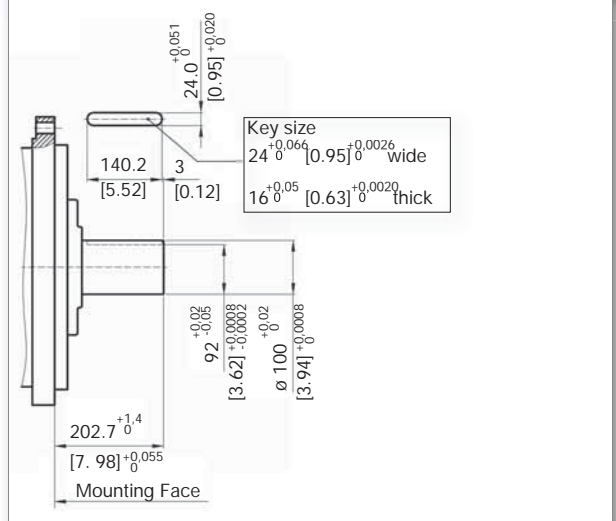

OUTPUT OPTIONS

YSTFC 325

P73 parallel key

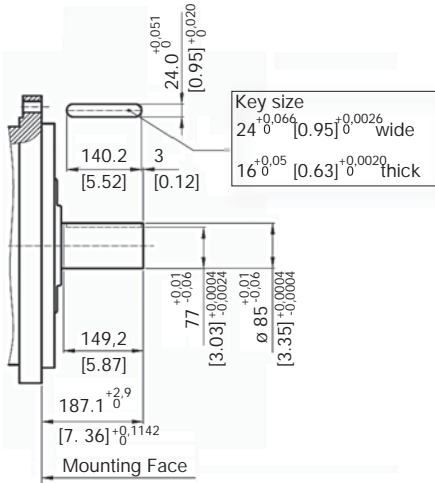

Q72 BS 3550 female spline

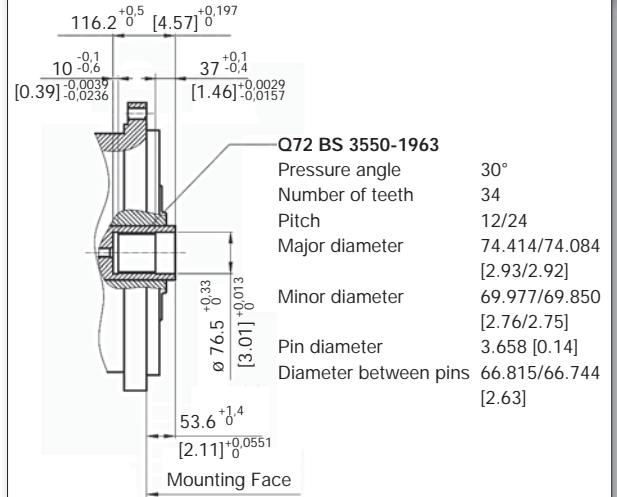

S71 BS 3550 spline shaft

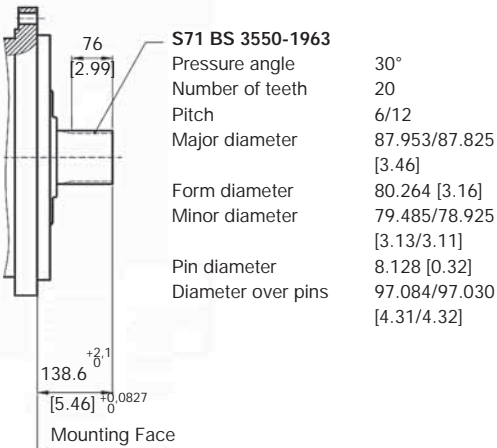

S72 splined shaft DIN 5480

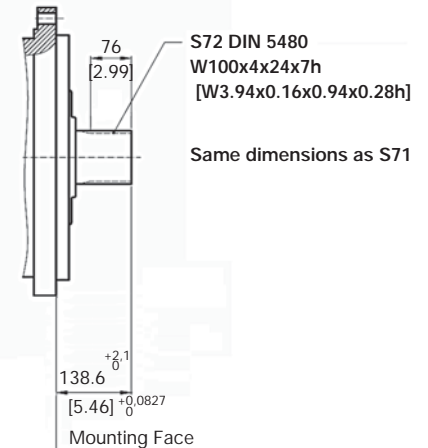

T71 tapered

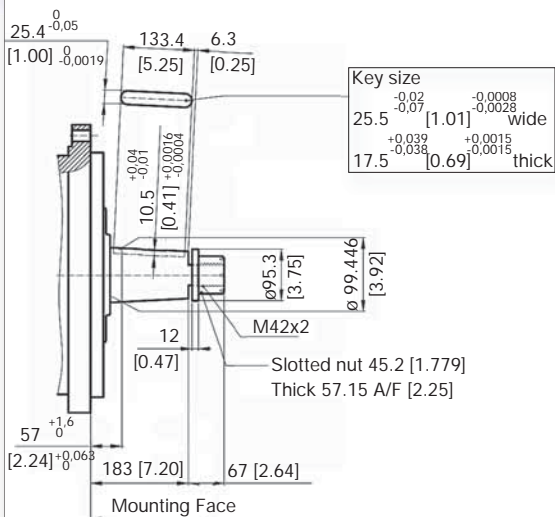

T72 short tapered shaft

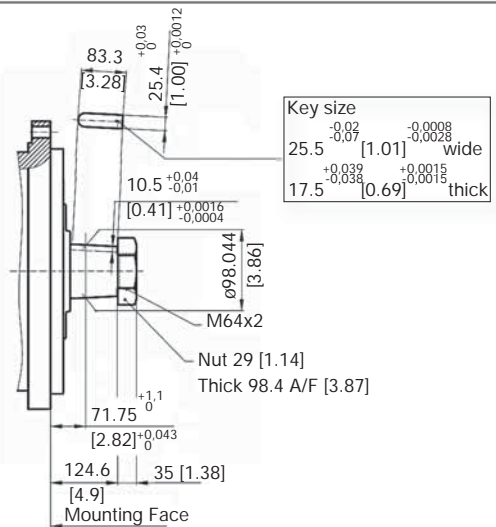

YSTFC (HD) 400

YSTFC (HD) 400

TECHNICAL SPECIFICATIONS

TYPE	Displacement				Pressure				Rated Torque		Unit Torque		Speed Range	Weight	
	nominal		theory		Rated pressure		Max Pressure		N.m	Lb/Ft	N.m/MPa	Lb/Ft/PSI	r/min	kg	lbs
	mL/r	in ³ /rev	mL/r	in ³ /rev	MPa	PSI	MPa	PSI							
YSTFC 400	5500	335.6	5510	336.2	23	3335	29	4205	18538	13673	806	4.10	120	495	1090
	6000	366.1	5996	365.9	23	3335	29	4205	20171	14877	877	4.46	120		
	6500	396.7	6483	395.6	21	3045	29	4205	19908	14683	948	4.82	120		
	6800	415	6807	415.4	21	3045	29	4205	20916	15427	996	5.07	120		

YSTFC (HD) 400

INSTALLATION DIMENSIONS WITH FO4 DISTRIBUTOR

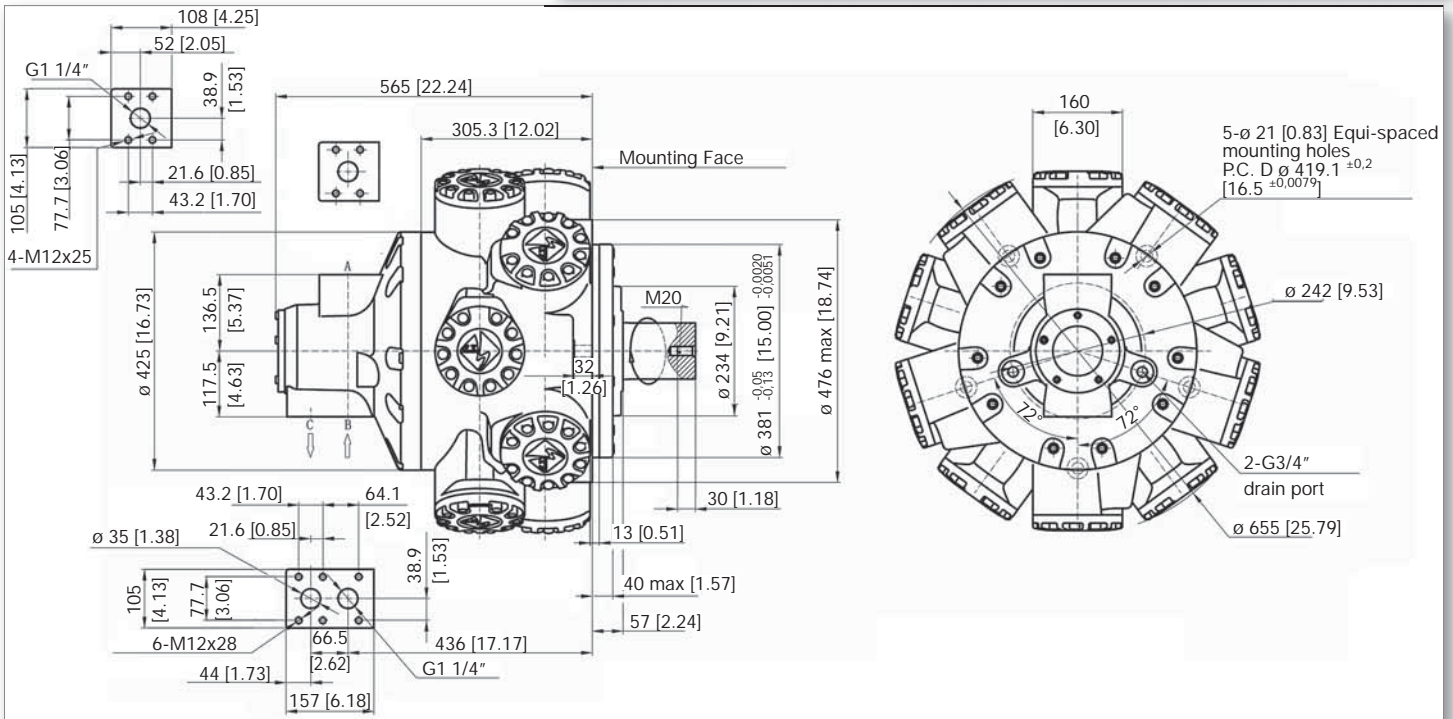

YSTFC 400-6800

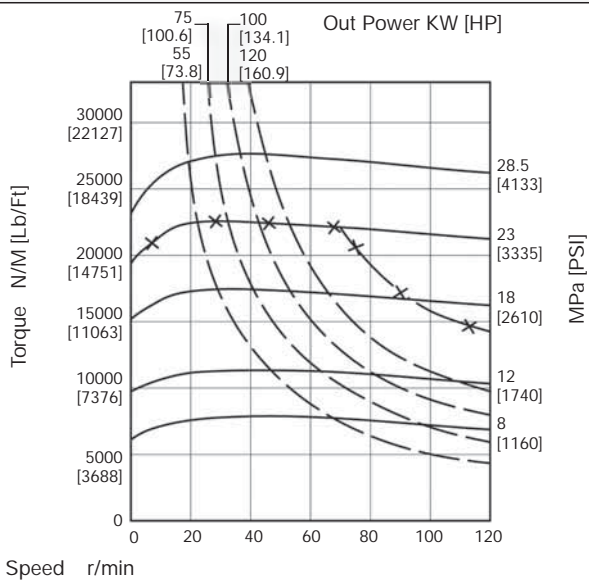

OUTPUT OPTIONS

YSTFC 400

P71 keyed

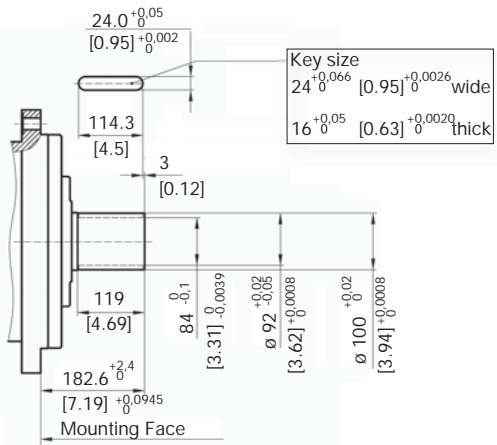

T71 Tapered

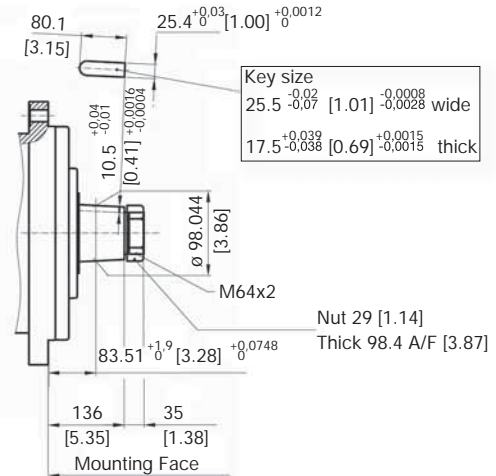

S71 BS 3550 splined

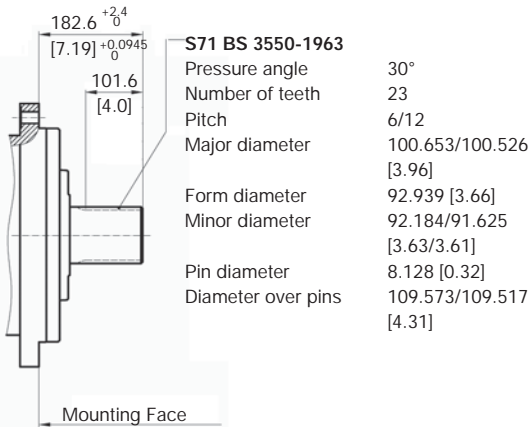

S72 DIN 5480 splined

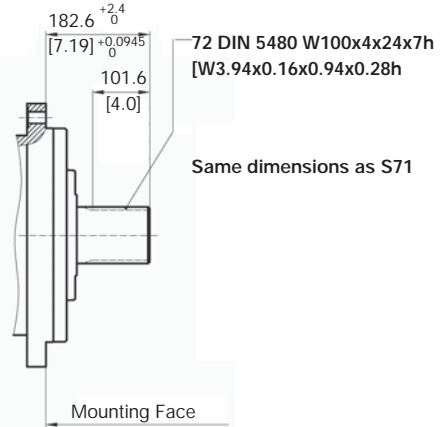

Q71 female splined BS 3550

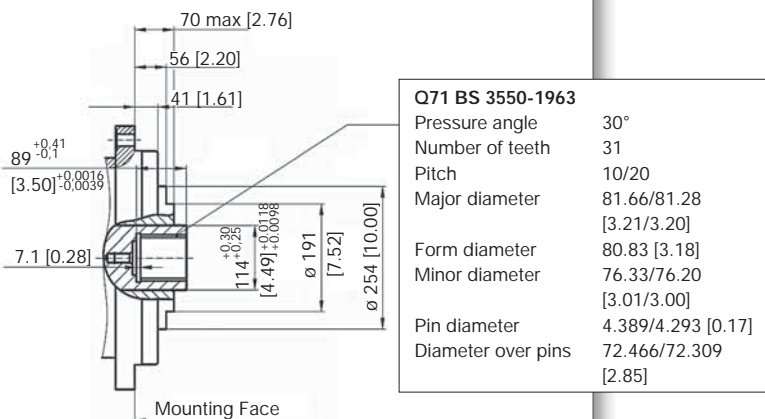

YSTFC (HD) 400

DISTRIBUTOR DATA

FO4 DISTRIBUTOR

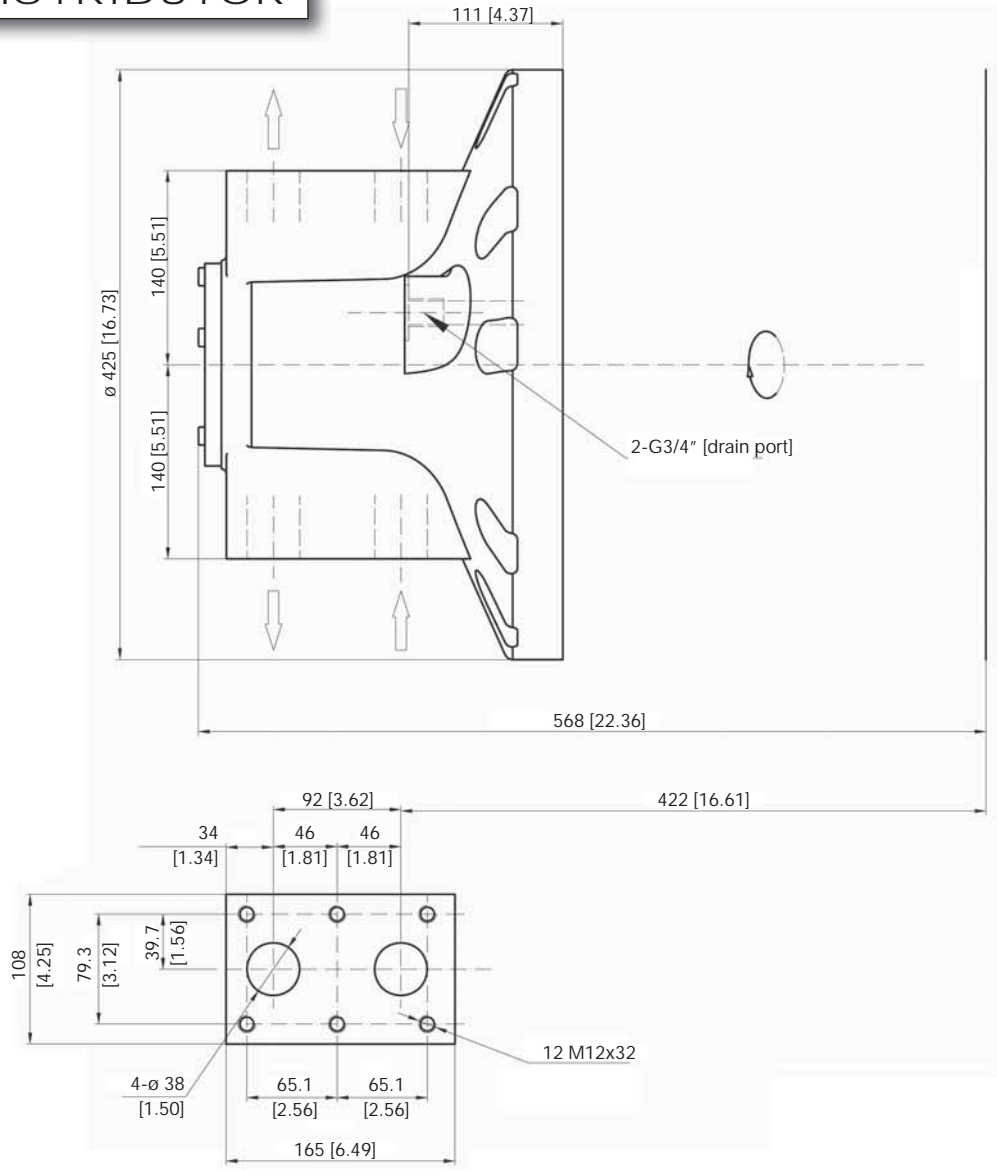

ORDERING CODE

**** *** *** *** *** *****

YSTFC - Standard Motor
YSTFC (HD) model of STF Hydraulic Motor

TYPE

NOMINAL DISPLACEMENT

OUTPUT SHAFT
 P - Parallel Keyed Shaft
 T - Taper Key Shaft
 S - Spline Shaft
 Q - Internal Spline Shaft

DISTRIBUTOR

OTHERS

EXAMPLE	YSTFC	270	4300	P71	F03	
----------------	--------------	------------	-------------	------------	------------	--

YSTFC-270-4300-P71-F03

Means YSTFC series low speed, high torque hydraulic motor
 type is 270
 nominal displacement is 4300 ml/r
 output shaft is P71
 distributor is F03
 Detailed mounting data refers to dimension drawing

YSTFC

QUALITY CONTROL INSTRUMENTS



The most modern and advanced quality control equipments are used to insure absolutely the best quality products available on the market today

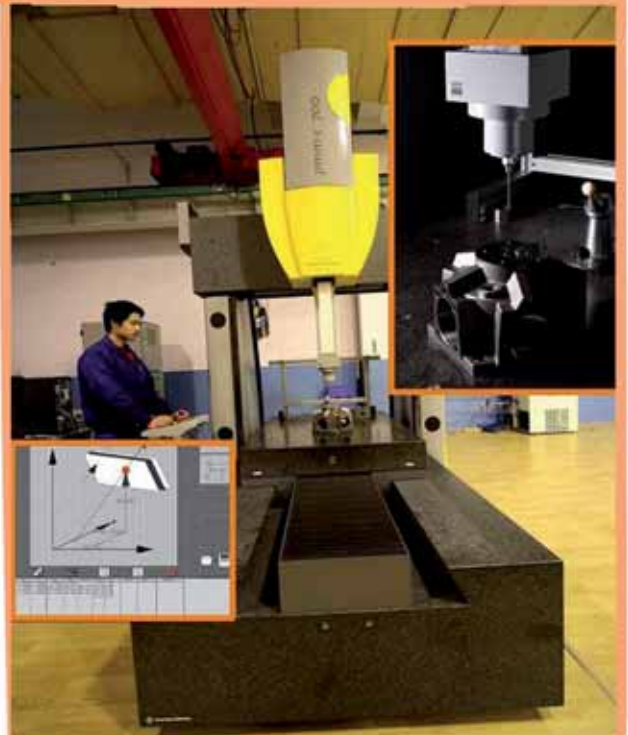

YSTFD CONTENTS

Product features	page 28
Main characteristics	page 28
YSTFD (HD) 100 Series	page 29
YSTFD (HD) 125 Series	page 33
YSTFD (HD) 200 Series	page 37
YSTFD (HD) 270 Series	page 41
YSTFD (HD) 325 Series	page 45



PRODUCT FEATURE

YSTFD (HD)

The YSTFD, two-speed series, Low Speed High Torque hydraulic motor is a further development of the YSTFC single speed unit.

This unit incorporates all the features of the single speed motors like hydrostatically balanced pistons and distributors, heavy duty tapered roller bearings and many other technological improvements over the competition to deliver the smoothest and most efficient power possible.

With 5 series , many high and low displacements from 100 to 5300 CC, these motors can fit such applications like marine, mining, constuction, forestry, farming, fishing and many more.

Each motor is available in two pre-selected displacement with a wide range of options. The displacements are selected by a manual control located on the motor or a remotely located control. Displacement can be easily changed while the motor is running.

MAIN CHARATCTERISTICS

YSTFD (HD)

1. Low Speed & High Torque output
2. High Efficiency
3. Smooth Running
4. Wide range of Displacements
5. Switch displacement while running
6. Change realized with either manual or remote control

YSTFD (HD) 100

YSTFD (HD) 100

ORDERING CODE

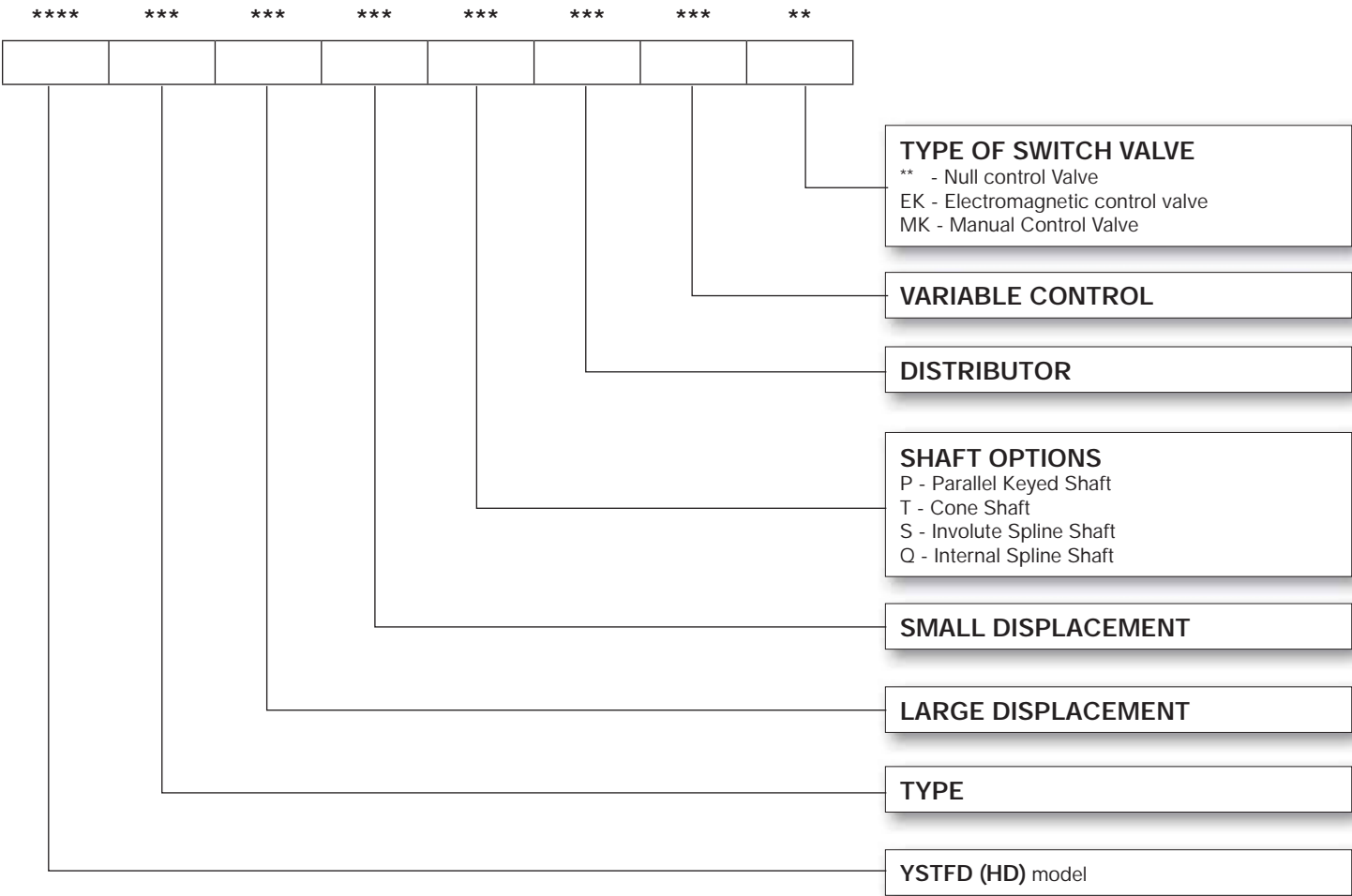

EXAMPLE

YSTFD	100	1200	600	S71	F02	L1A	**
-------	-----	------	-----	-----	-----	-----	----

YSTFD-100-1200-600-S71-F02-L1A-**

Series	YSTFD
Type	100
Displacement	1200/600 cc
Shaft options	S71
Distributor	F02
Variable control	L1A
Type of switch valve	**

TECHNICAL SPECIFICATIONS

YSTFD (HD) 100

Nominal displacement		1600	1500	1400	1300	1200	1100	1000	900	800	700	600	500	400	300	200	100
Displacement	ml/r	1580	1481	1383	1284	1185	1086	987	889	790	691	592	494	395	296	197	98
	in ³ /r	96.4	90.3	84.4	78.3	72.3	66.3	60.2	54.7	48.2	42.2	36.1	30.1	24.1	18.1	12.0	6.0
Unit Torque	N.m/Mpa	225	212	198	184	169	155	140	125	108	94	78	68	45	30	18	0
	lb-ft/PSI	11.48	10.81	10.10	9.38	8.62	7.91	7.14	6.8	5.51	4.99	3.98	3.47	2.30	1.53	0.92	0
Max. Cont. Speed	r/min	260	270	280	300	330	370	405	485	540	540	540	540	540	540	540	900
Max. Cont Power	KW	99	98	96	93	90	84	82	79	74	69	57	46	35	23	10	0
	HP	132.7	131.3	128.6	124.6	120.6	112.6	109.9	105.9	99.2	92.5	76.4	61.6	46.9	30.8	13.4	0
Max. Top Power	KW	120	117	113	109	105	100	97	93	87	81	68	54	40	28	14	0
	HP	160.8	156.8	151.4	146.1	140.7	134.0	129.0	124.6	116.6	108.5	91.1	72.4	53.6	37.5	18.8	0
Max. Cont Pressure	Mpa	21	21	21	21	21	21	21	21	21	21	21	21	21	21	21	15
	PSI	3045	3045	3045	3045	3045	3045	3045	3045	3045	3045	3045	3045	3045	3045	3045	2175
Max. Top Pressure	Mpa	25	25	25	25	25	25	25	25	25	25	25	25	25	25	25	15
	PSI	3625	3625	3625	3625	3625	3625	3625	3625	3625	3625	3625	3625	3625	3625	3625	2175

DISPLACEMENT OPTIONS

YSTFD (HD) 100

large displacement: 1600, 1500, 1400, 1300, 1200, 1100, 1000, 900, 800

small displacement: 1100, 1000, 800, 700, 600, 500, 400, 300, 200, 100

FUNCTION SYMBOLS

YSTFD (HD) 100

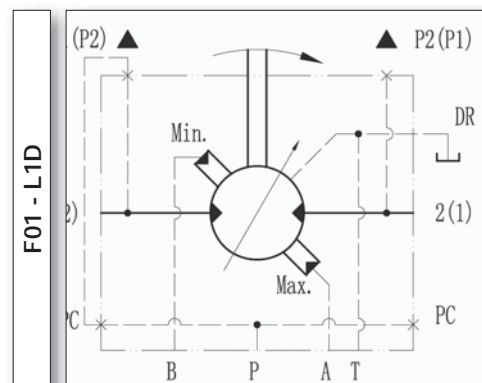
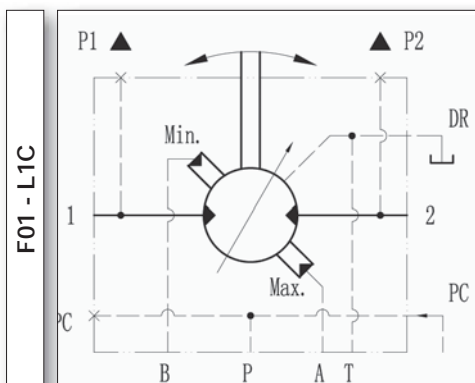
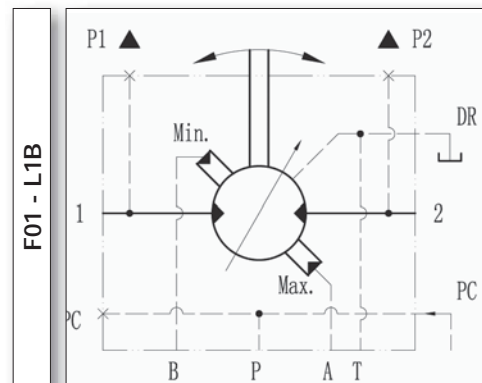
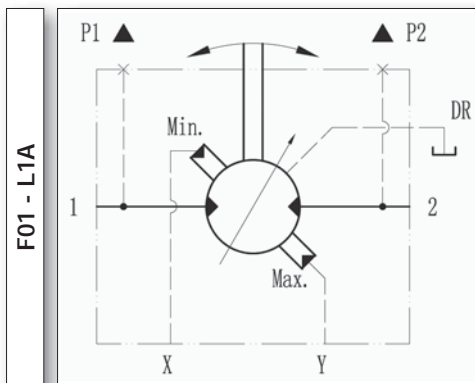

YSTFD (HD) 100

INSTALLATION DIMENSIONS WITH
FO1 DISTRIBUTOR

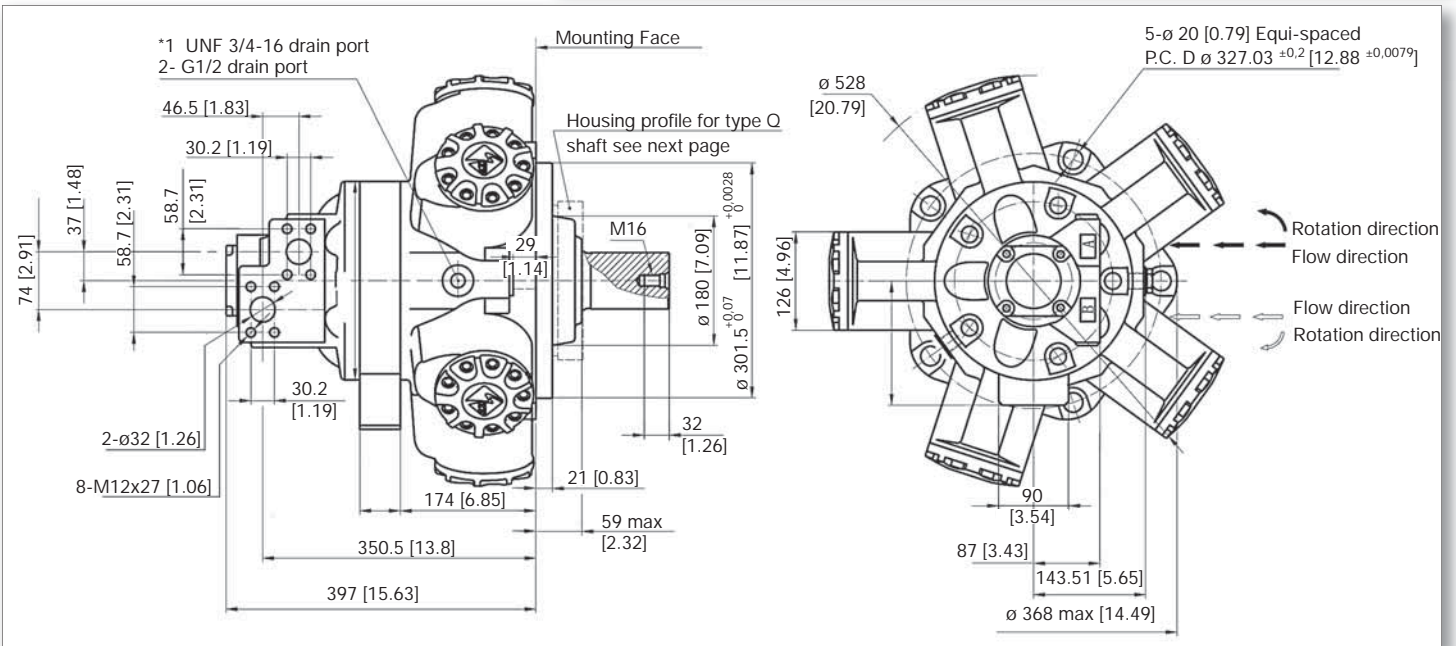

YSTFD (HD) 100

VARIABLE CONTROL MOUNTING DATA

L1A MOUNTING DATA

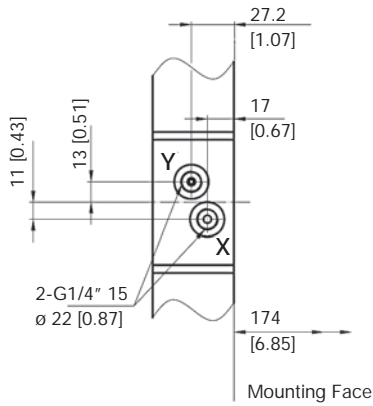

L1B-L1C-L1D - MOUNTING DATA

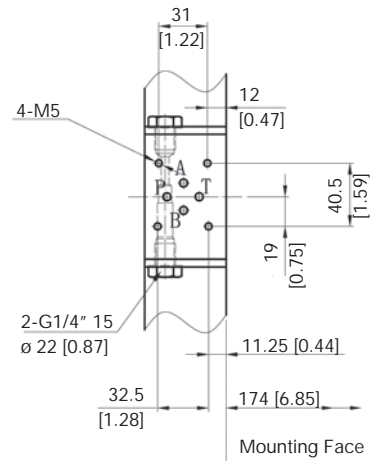

OUTPUT OPTIONS

YSTFD (HD) 100

P 71 keyed

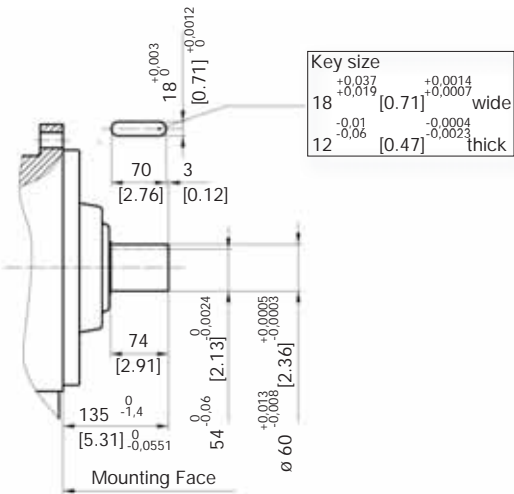

S 71 BS 3550 splined

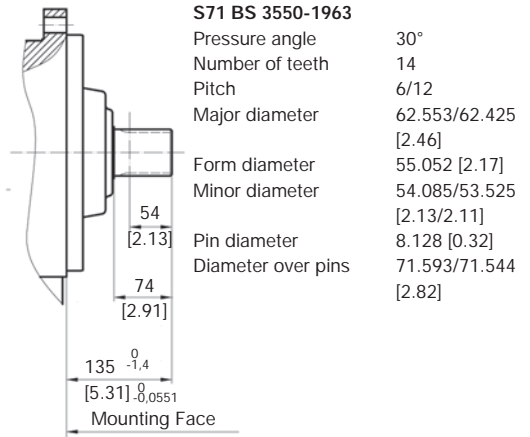

S 72 DIN 5480 splined

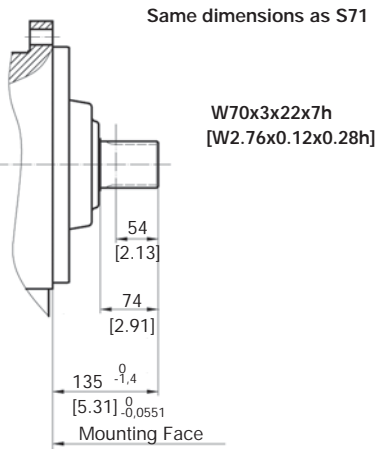

Q 71 Female splined

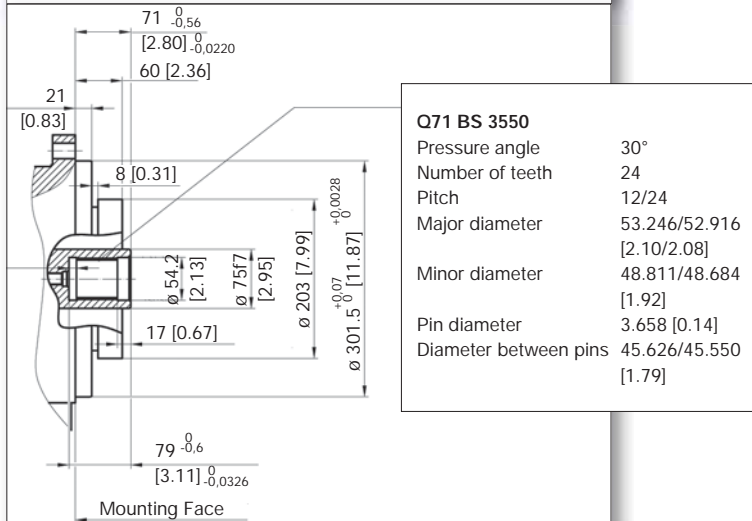

YSTFD (HD) 125

YSTFD (HD) 125

ORDERING CODE

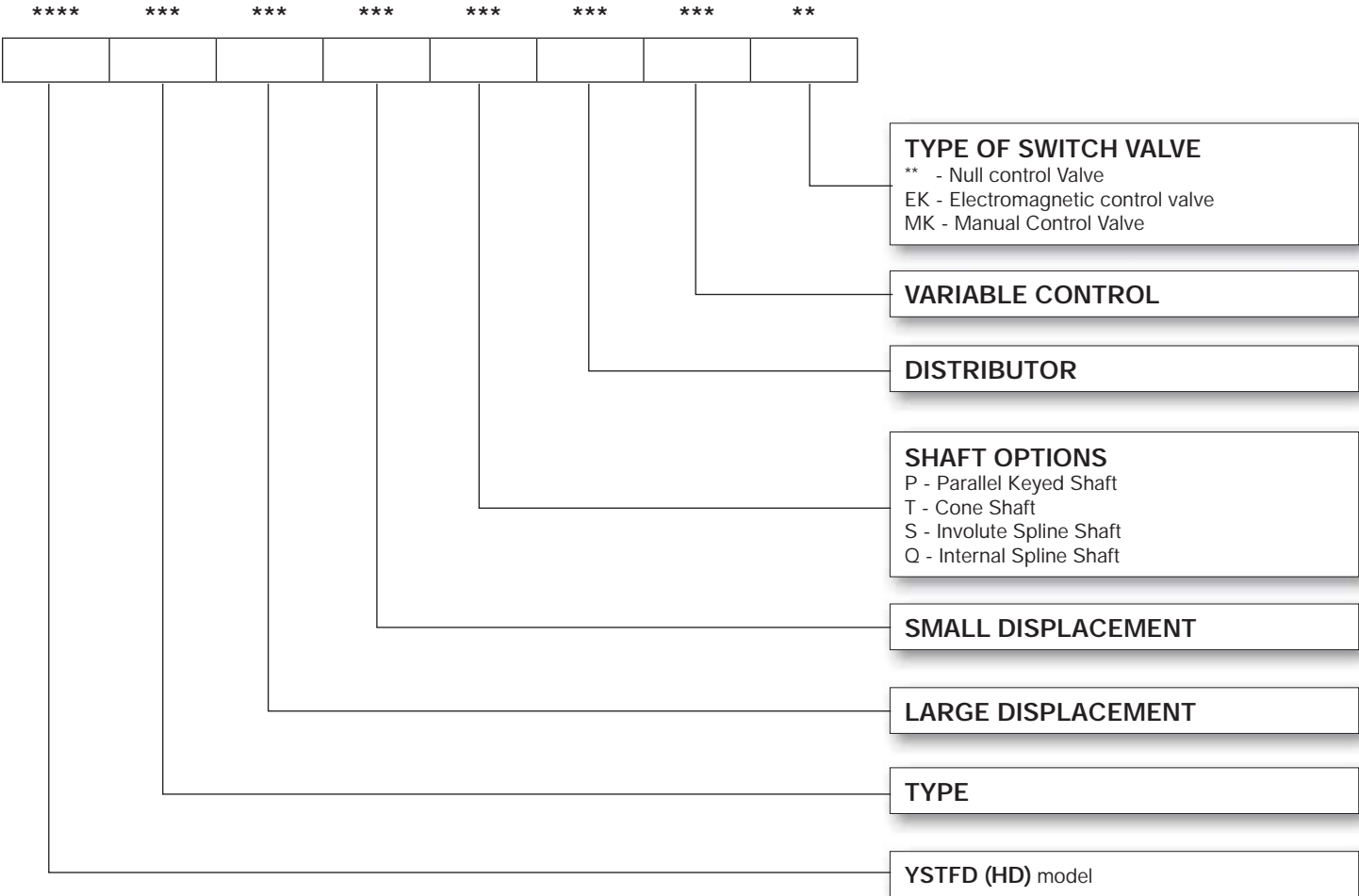

EXAMPLE

YSTFD	125	2000	1000	S71	F02	L1A	**
-------	-----	------	------	-----	-----	-----	----

YSTFD-125-2000-1000-S71-F02-L1A-**

Series	YSTFD
Type	125
Displacement	2000/1000 cc
Shaft options	S71
Port Size	F02
Variable control	L1A
Type of switch valve	**

TECHNICAL SPECIFICATIONS

YSTFD (HD) 125

Nominal displacement		2100	2000	1800	1600	1500	1300	1200	1000	830	670	510	350	190	110
Displacement	ml/r	2066	1973	1811	1649	1487	1325	1163	1001	839	677	515	353	191	110
	in ³ /r	126.1	120.4	110.5	118.9	90.7	80.8	70.9	61.1	51.2	41.3	31.4	21.5	11.6	6.6
Unit Torque	N.m/Mpa	293	281	258	231	206	180	154	125	100	79	57	39	6	0
	lb.-ft./PSI	14.94	14.33	13.16	11.78	10.51	9.18	7.85	6.8	5.10	4.03	2.41	1.99	0.31	0
Max. Cont. Speed	r/min	170	175	190	210	230	265	305	350	395	485	540	540	540	900
Max. Cont Power	KW	91	89	83	77	71	66	60	55	48	42	33	16	3	0
	HP	121.9	119.1	111.2	103.2	95.1	88.4	80.4	73.7	64.3	56.3	44.2	21.4	4.0	0
Max. Top Power	KW	106	104	99	95	90	85	79	73	65	57	44	28	5	0
	HP	142.0	139.4	132.7	127.3	120.6	113.9	105.9	97.8	87.1	76.4	58.9	37.5	6.7	0
Max. Cont Pressure	Mpa	21	21	21	21	21	21	21	21	21	21	21	21	21	15
	PSI	3045	3045	3045	3045	3045	3045	3045	3045	3045	3045	3045	3045	3045	2175
Max. Top Pressure	Mpa	25	25	25	25	25	25	25	25	25	25	25	25	25	15
	PSI	3625	3625	3625	3625	3625	3625	3625	3625	3625	3625	3625	3625	3625	2175

DISPLACEMENT OPTIONS

YSTFD (HD) 125

large displacement: 2100, 2000, 1800, 1600

small displacement: 1600, 1500, 1300, 1200, 1000, 830, 670, 510, 350, 190, 110

FUNCTION SYMBOLS

YSTFD (HD) 125

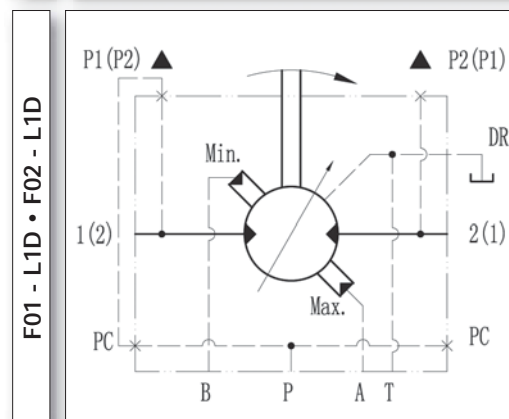
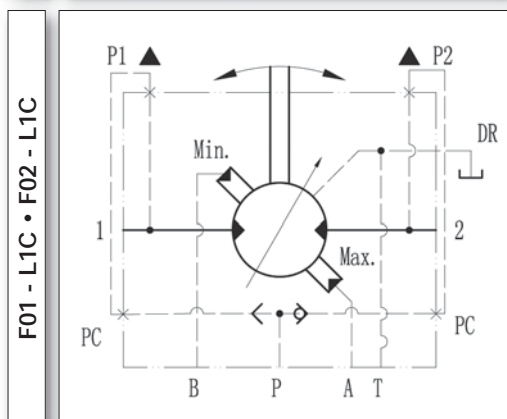
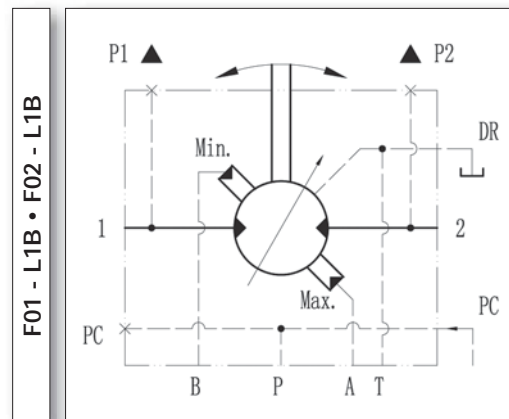
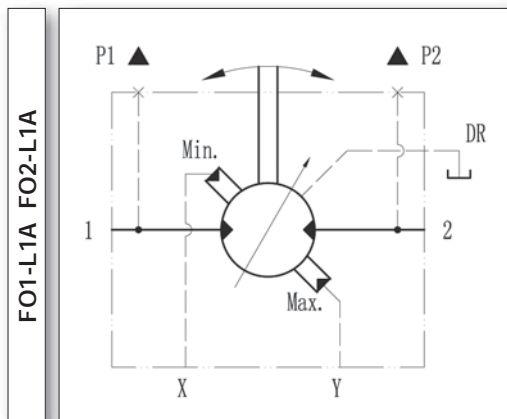

YSTFD (HD) 125

INSTALLATION DIMENSIONS WITH FO2 DISTRIBUTOR

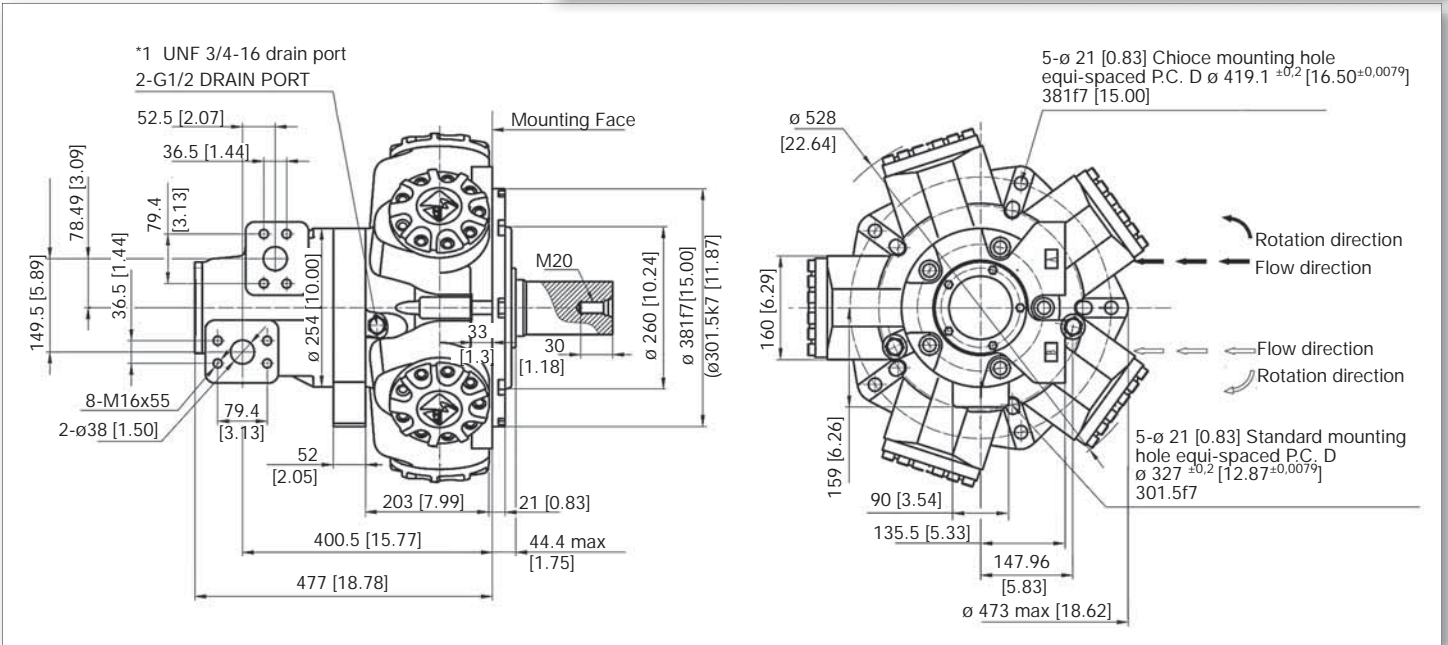

YSTFD (HD) 125

VARIABLE CONTROL MOUNTING DATA

F1 DISTRIBUTOR MOUNTING DIMENSIONS

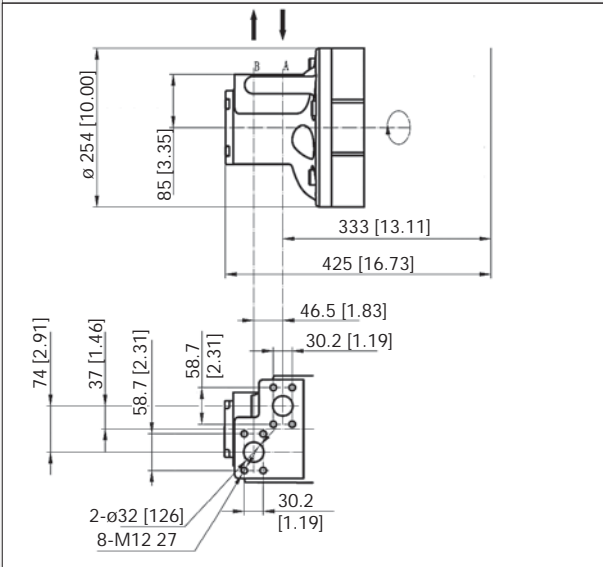

VARIABLE CONTROL DIMENSIONS

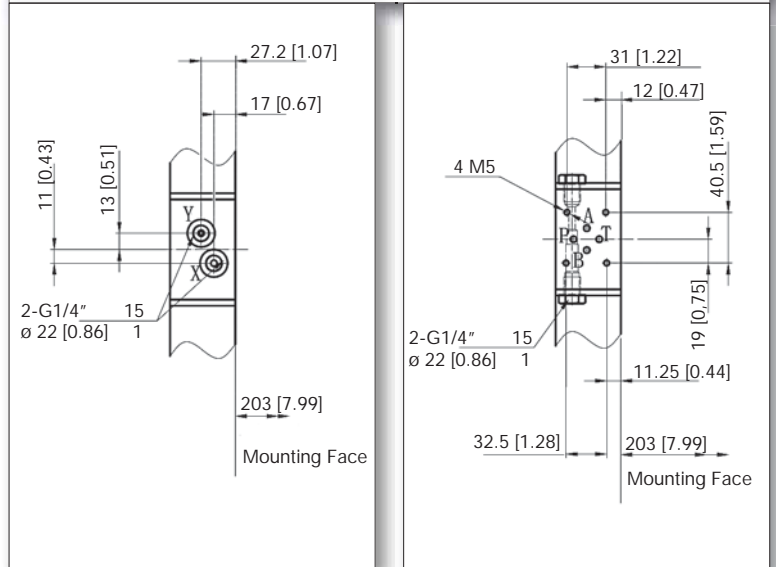

OUTPUT OPTIONS

YSTFD (HD) 125

P 71 keyed

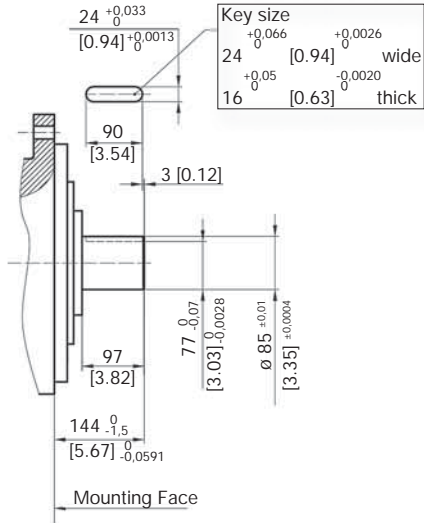

S 71 BS 3550 splined

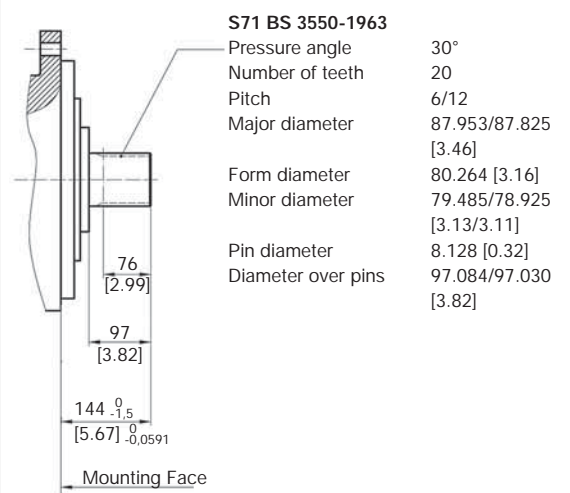

S 72 DIN 5480 splined

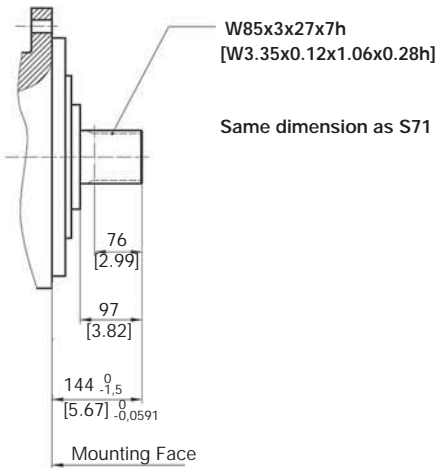

Q 71 Female splined

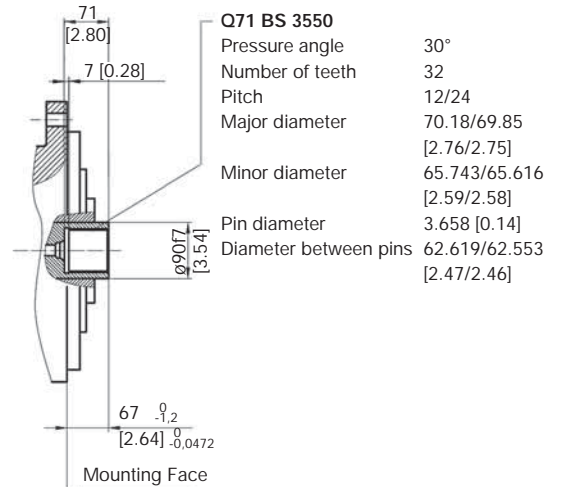

YSTFD (HD) 200

YSTFD (HD) 200

ORDERING CODE

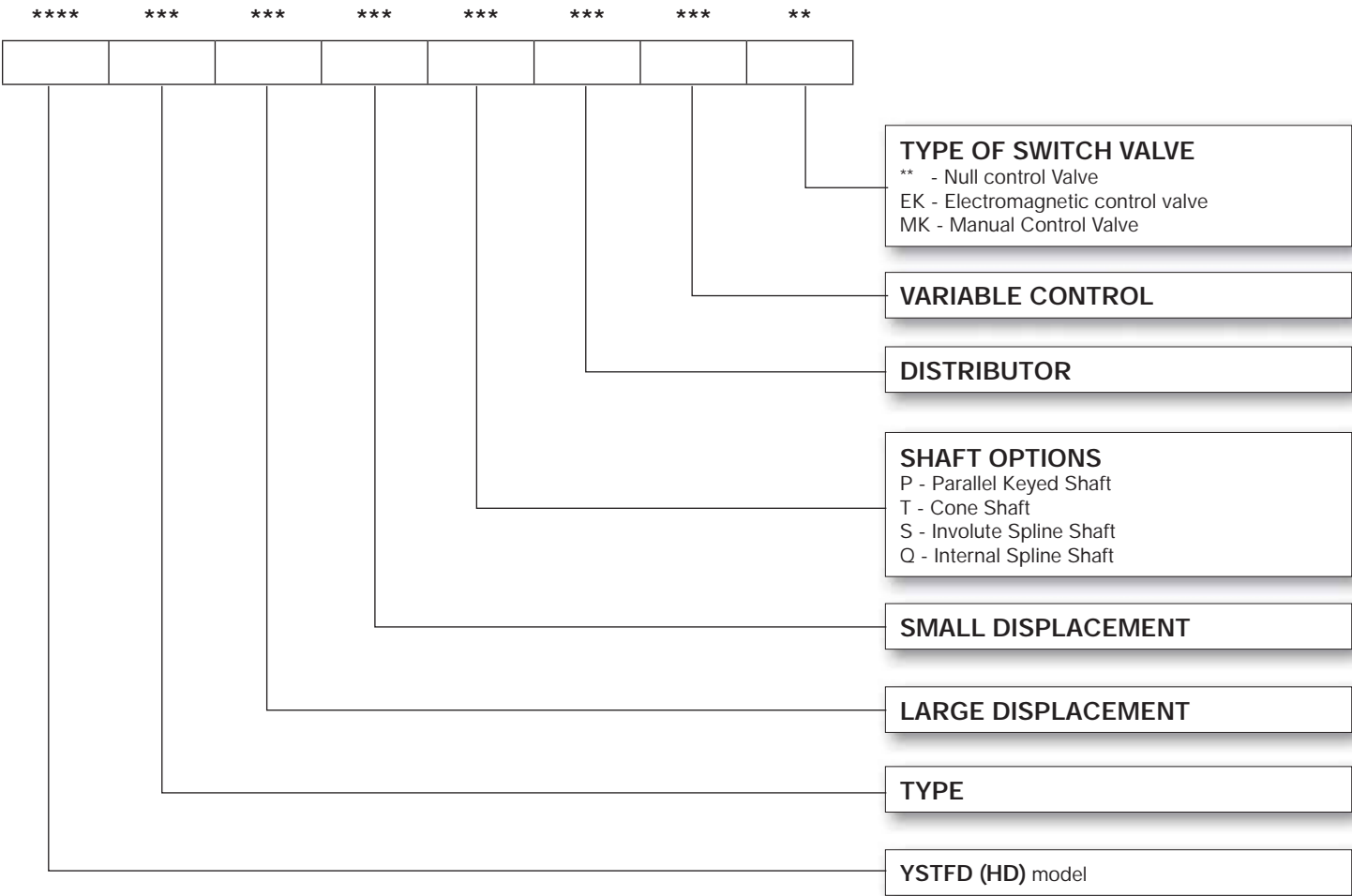

EXAMPLE

YSTFD	200	2600	1300	S71	F02	L1A	**
--------------	------------	-------------	-------------	------------	------------	------------	-----------

YSTFD-200-2600-1300-S71-F02-L1A-**

Series	YSTFD
Type	200
Displacement	2600/1300 cc
Shaft options	S71
Distributor	F02
Variable control	L1A
Type of switch valve	**

TECHNICAL SPECIFICATIONS

YSTFD (HD) 200

Nominal displacement		3100	2900	2800	2600	2400	2300	2100	2000	1800	1600	1500	1300	1200	1000	830	670	510	350	190	110
Displacement	ml/r	3080	2958	2796	2634	2472	2310	2148	1973	1811	1649	1487	1325	1163	1001	839	677	515	353	191	110
	in ³ /R	187.9	180.5	170.6	160.7	156.8	140.9	131.1	120.4	110.5	100.6	90.7	80.8	70.9	61.1	51.2	41.3	31.4	21.5	11.6	6.6
Unit Torque	N.m/ Mpa	447	422	400	375	351	326	300	281	258	231	206	180	154	125	100	79	57	30	6	0
	lb-ft/ PSI	22.8	21.52	20.40	19.13	17.90	16.3	15.30	14.33	13.16	11.78	10.51	9.18	7.85	6.38	5.10	4.03	2.91	1.53	0.31	0
Max.Cont.Speed	r/min	110	115	125	135	140	150	160	175	190	210	230	265	305	350	395	485	540	540	540	900
Max. Cont Power	KW	110	110	110	105	100	96	92	89	83	77	71	66	60	55	48	42	33	16	3	0
	HP	147.4	147.4	147.4	140.7	134.0	128.6	123.3	119.3	111.2	103.2	95.1	88.4	80.4	73.2	64.3	56.3	44.2	21.4	4.0	0
Max. Top Power	KW	135	135	135	130	125	120	114	104	99	95	90	85	79	73	65	57	44	28	5	0
	HP	180.9	180.9	180.9	174.2	167.5	160.8	152.8	139.4	132.7	127.3	120.6	113.9	105.9	97.8	87.1	76.3	58.9	37.5	6.7	0
Max. Cont Pressure	Mpa	21	21	21	21	21	21	21	21	21	21	21	21	21	21	21	21	21	21	21	15
	PSI	3045	3045	3045	3045	3045	3045	3045	3045	3045	3045	3045	3045	3045	3045	3045	3045	3045	3045	3045	3045
Max. Top Pressure	Mpa	25	25	25	25	25	25	25	25	25	25	25	25	25	25	25	25	25	25	25	15
	PSI	3625	3625	3625	3625	3625	3625	3625	3625	3625	3625	3625	3625	3625	3625	3625	3625	3625	3625	3625	2175

DISPLACEMENT OPTIONS

YSTFD (HD) 200

large displacement: 3100, 2900, 2800, 2600, 2400, 2300, 2100, 2000, 1800, 1600

small displacement: 2300, 2100, 2000, 1800, 1600, 1500, 1300, 1200, 1000, 830, 670, 510, 350, 190, 110

FUNCTION SYMBOLS

YSTFD (HD) 200

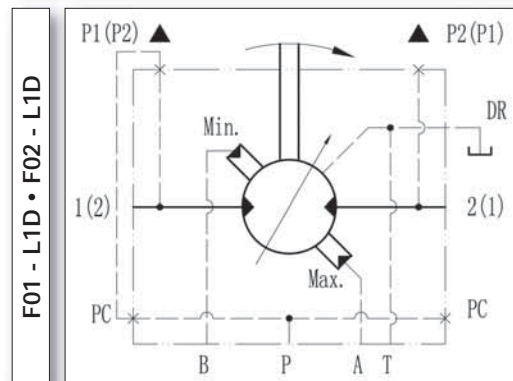
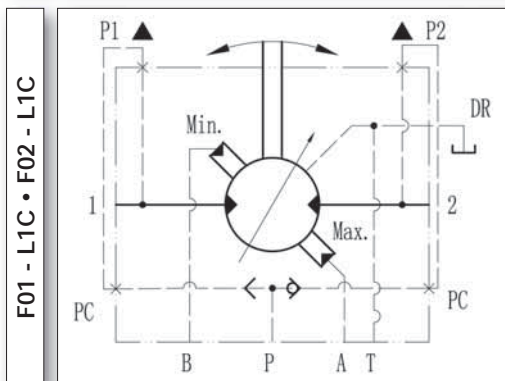
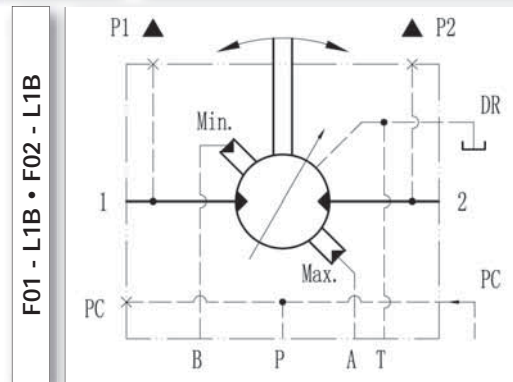
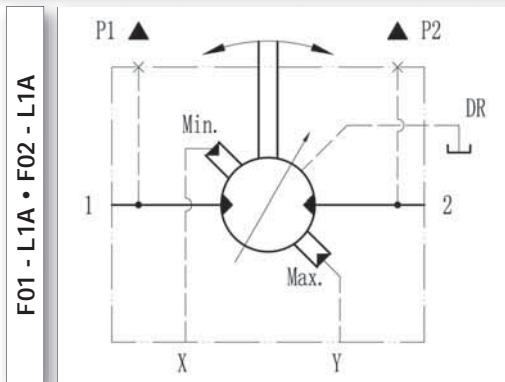

YSTFD (HD) 200

INSTALLATION DIMENSIONS WITH FO2 DISTRIBUTOR

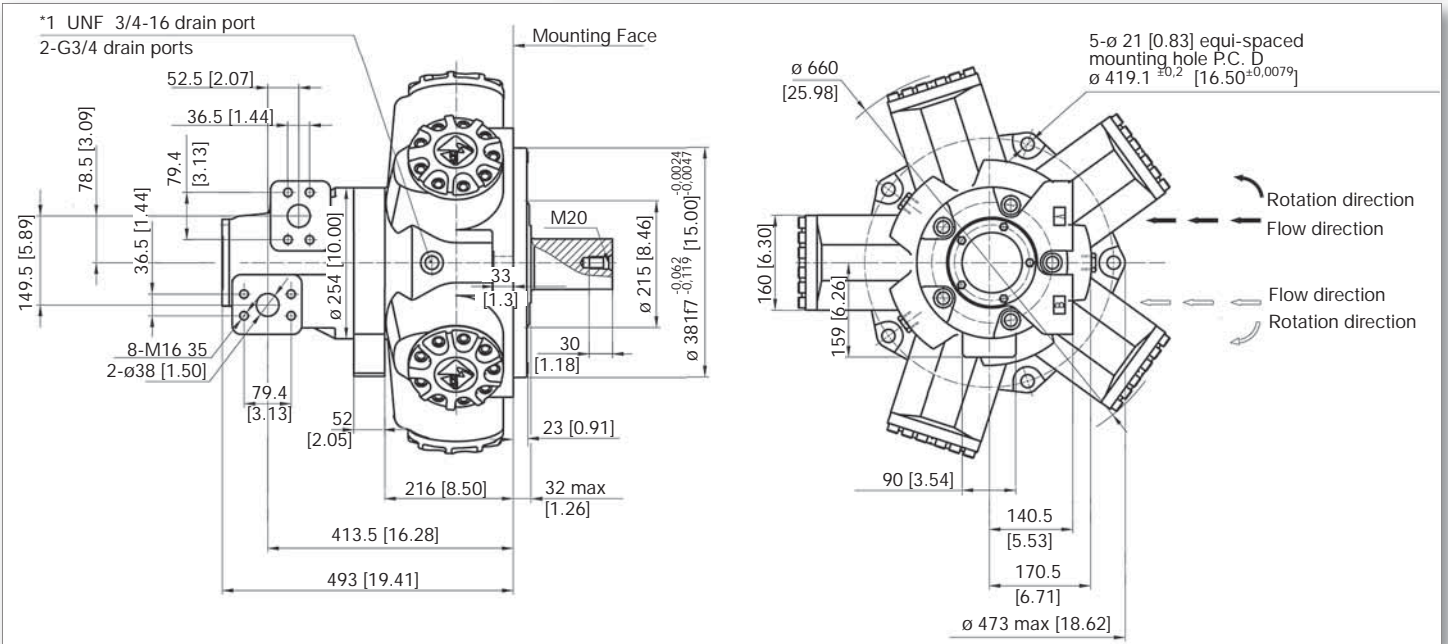

YSTFD (HD) 200

VARIABLE CONTROL MOUNTING DATA

F1 DISTRIBUTOR MOUNTING DIMENSIONS

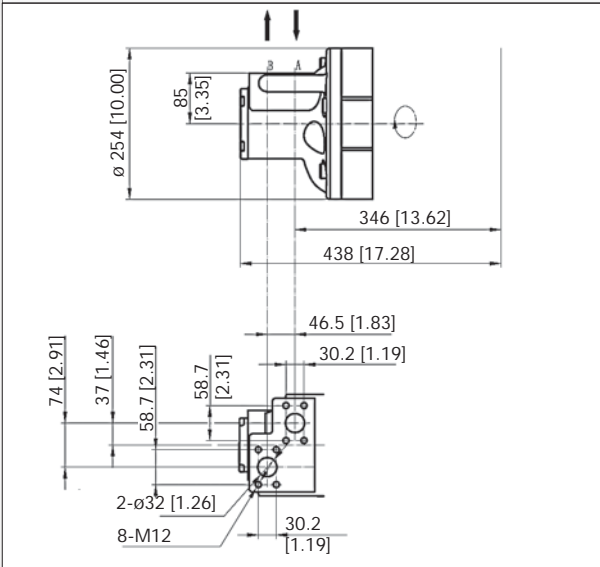

VARIABLE CONTROL DIMENSIONS

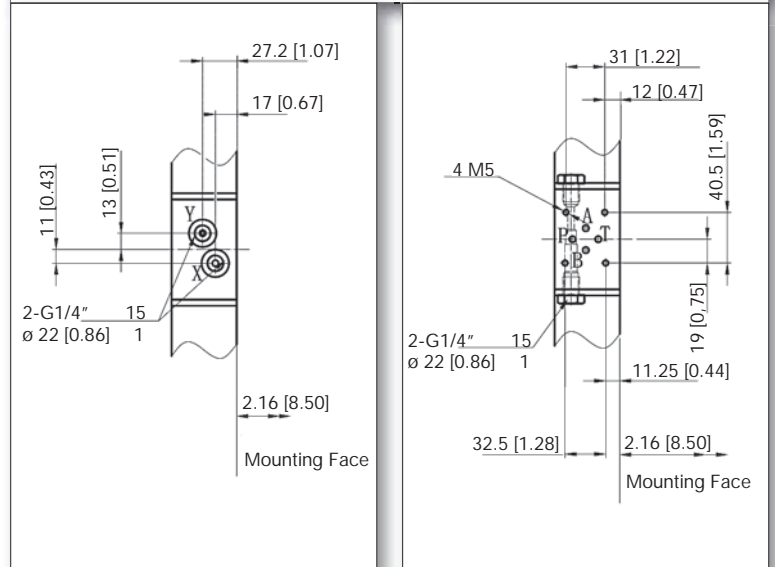

YSTFD

OUTPUT OPTIONS

YSTFD (HD) 200

P 71 keyed

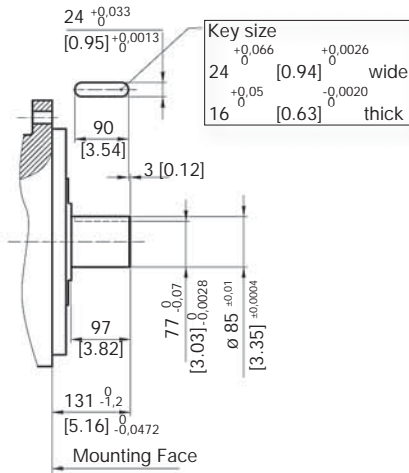

S 71 BS 3550 splined

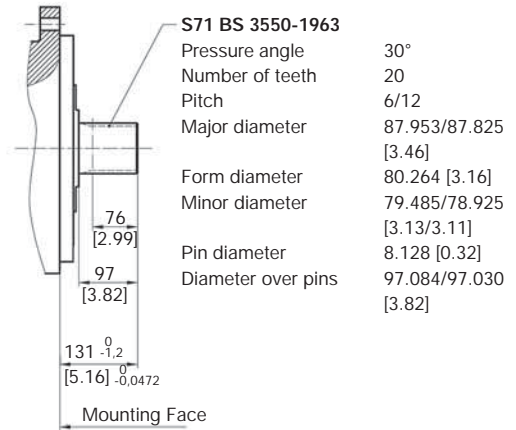

S 72 DIN 5480 splined

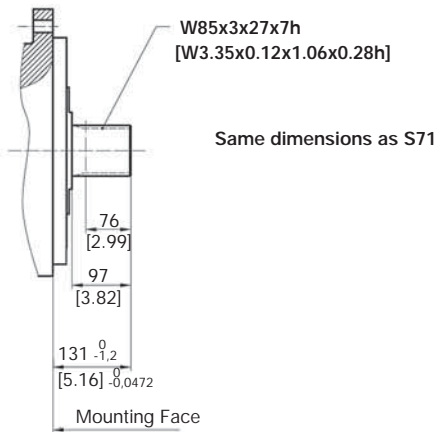

Q 71 Female splined

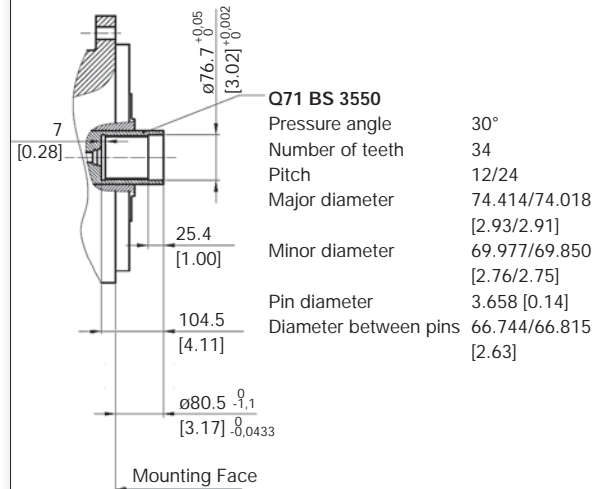

YSTFD (HD) 270

YSTFD (HD) 270

ORDERING CODE

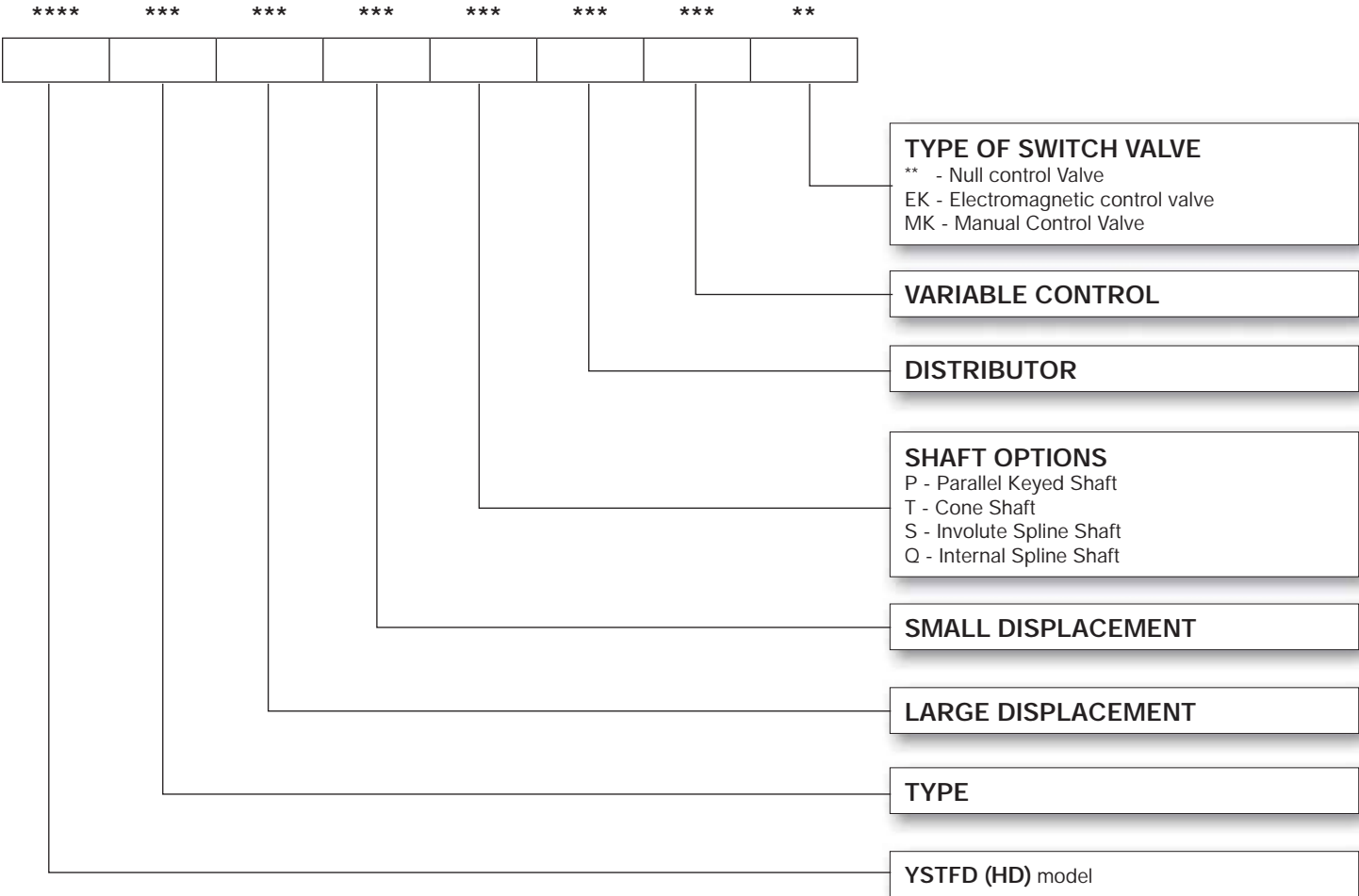

EXAMPLE

YSTFD	270	4100	1900	S71	F02	L1A	**
-------	-----	------	------	-----	-----	-----	----

YSTFD-270-4100-1900-S71-F02-L1A-**

Series	YSTFD
Type	270
Displacement	4100/1900 cc
Shaft options	S71
Port Size	F02
Variable control	L1A
Type of switch valve	**

TECHNICAL SPECIFICATIONS

YSTFD (HD) 270

Nominal displacement		4600	4100	3600	3300	3000	2600	2300	1900	1600	1400	970	680	340	170
Displacement	ml/r	4597	4086	3632	3291	2951	2610	2270	1930	1646	1362	965	681	340	170
	in ³ /R	280.5	249.3	221.6	200.8	180.1	159.2	138.5	117.8	100.4	83.1	58.9	41.5	20.7	10.4
Unit Torque	N.m/Mpa	657	585	514	460	419	356	310	259	210	168	108	73	24	0
	lb·ft/PSI	33.51	29.83	26.21	23.46	21.37	18.16	15.81	13.21	10.71	8.57	5.51	3.72	1.22	0
Max. Cont. Speed	r/min	108	120	135	145	165	180	215	240	290	315	315	315	315	900
Max. Cont Power	KW	123	115	104	97	90	83	76	68	59	48	37	25	8	0
	HP	164.8	154.1	139.4	129.9	120.6	111.2	101.8	91.1	79.1	64.3	49.6	33.5	10.7	0
Max. Top Power	KW	153	149	142	136	129	122	112	102	91	81	68	47	12	0
	HP	205.0	199.7	190.3	182.2	172.9	163.5	150.1	136.7	121.9	108.5	91.1	62.9	16.1	0
Max. Cont Pressure	Mpa	21	21	21	21	21	21	21	21	21	21	21	21	21	15
	PSI	3045	3045	3045	3045	3045	3045	3045	3045	3045	3045	3045	3045	3045	2175
Max. Top Pressure	Mpa	25	25	25	25	25	25	25	25	25	25	25	25	25	15
	PSI	3625	3625	3625	3625	3625	3625	3625	3625	3625	3625	3625	3625	3625	2175

DISPLACEMENT OPTIONS

YSTFD (HD) 270

large displacement: 4600, 4100, 3600, 3300

small displacement: 3300, 3000, 2600, 2300, 1900, 1600, 1400, 970, 680, 340, 170

FUNCTION SYMBOLS

YSTFD (HD) 270

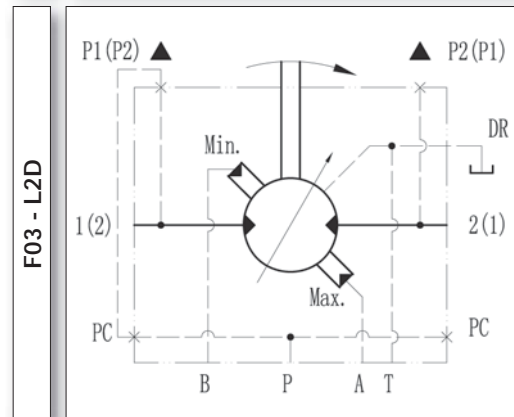
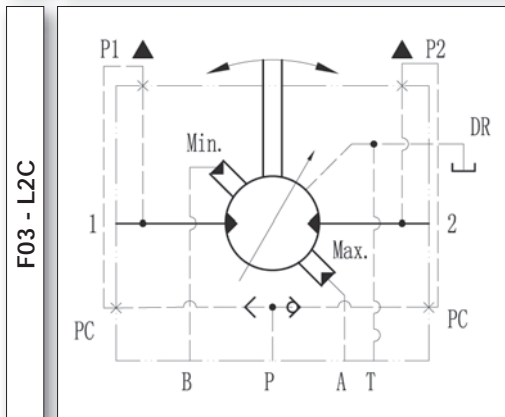
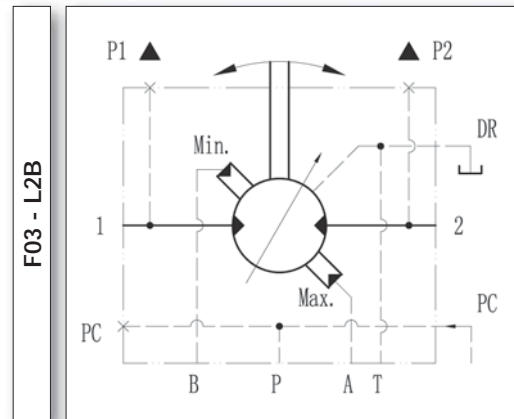
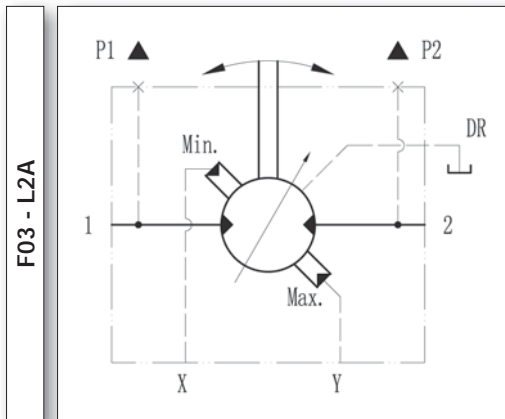

YSTFD (HD) 270

INSTALLATION DIMENSIONS WITH FO3 DISTRIBUTOR

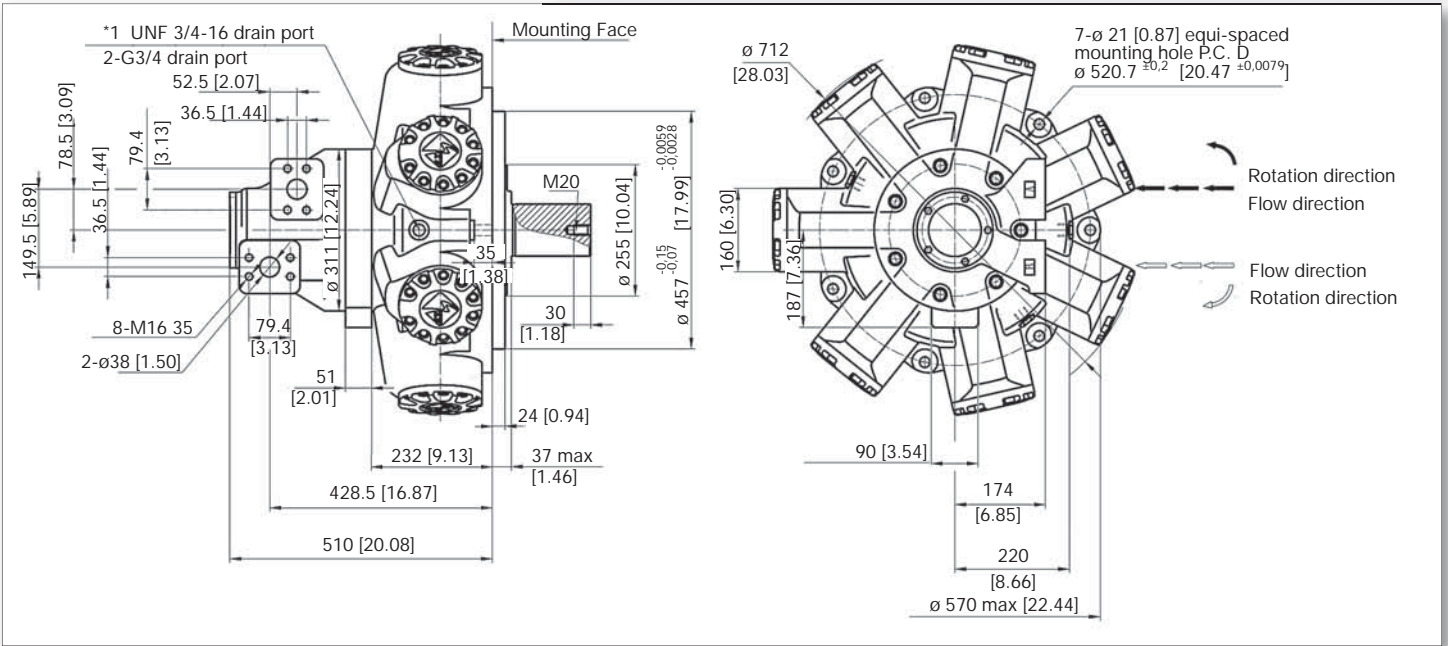

YSTFD (HD) 270

VARIABLE CONTROL MOUNTING DATA

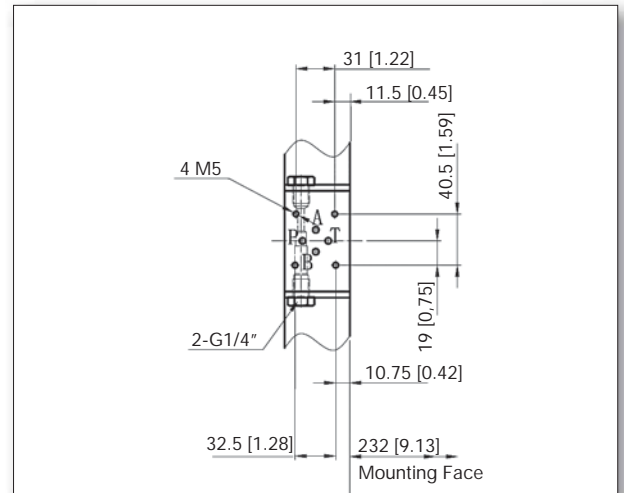
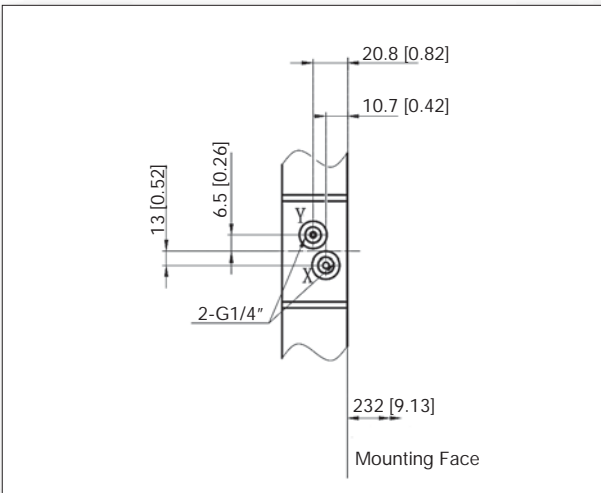

YSTFD

OUTPUT OPTIONS

YSTFD (HD) 270

P71 keyed

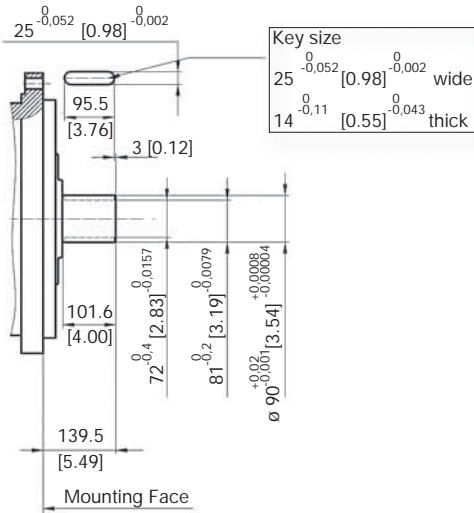

S71 BS 3550 splined

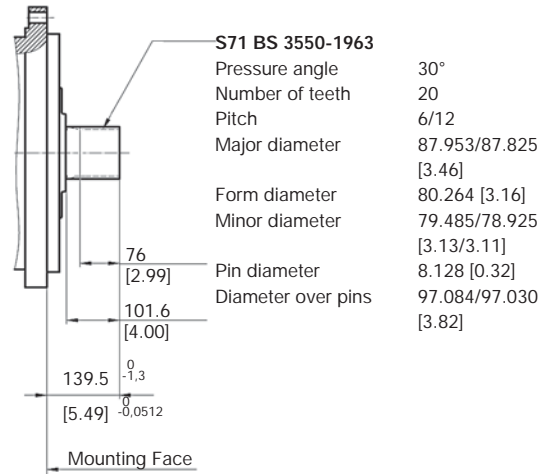

S72 DIN 5480 splined

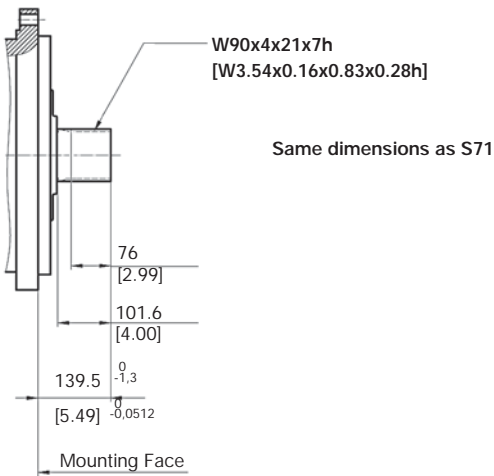

Q71 Female splined

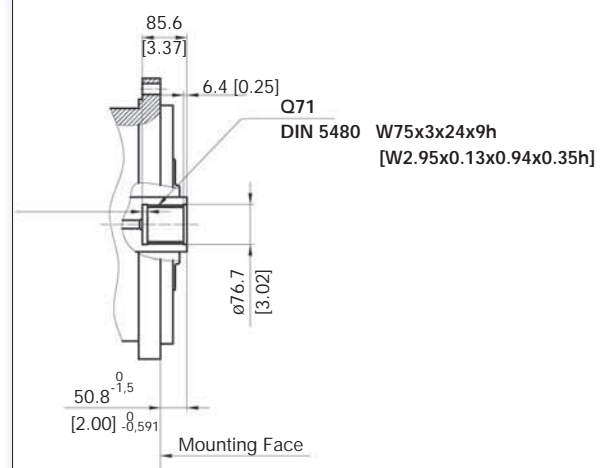

YSTFD (HD) 325

YSTFD (HD) 325

ORDERING CODE

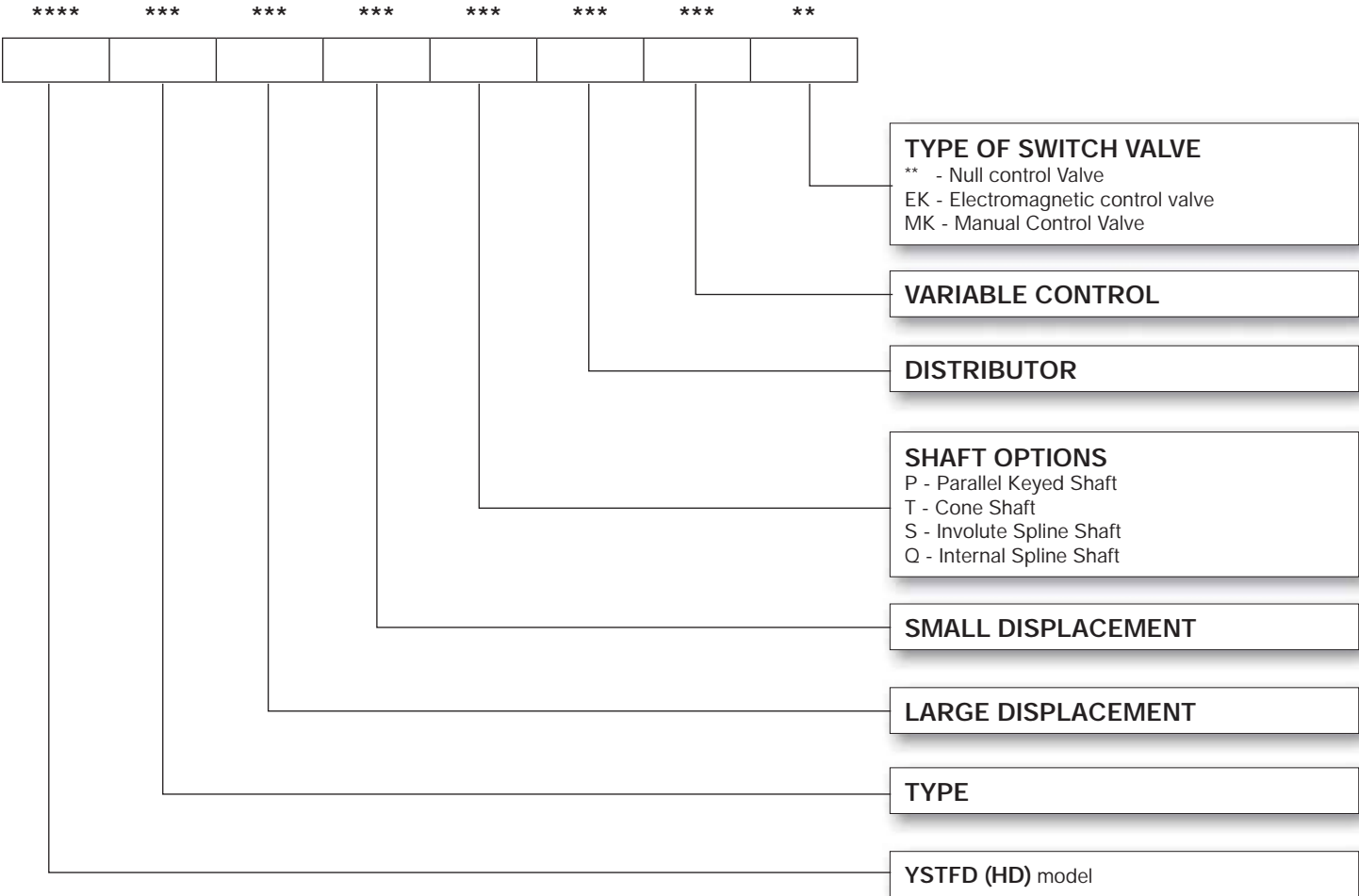

EXAMPLE

YSTFD	325	__	__	S71	F03	L2A	**
-------	-----	----	----	-----	-----	-----	----

YSTFD-325-__-__-S71-F03-L2A-**

Series	YSTFD
Type	325
Displacement	__ / __ cc
Shaft options	S71
Port Size	F03
Variable control	L2A
Type of switch valve	**

TECHNICAL SPECIFICATIONS

YSTFD (HD) 325

Nominal displacement		5300	5100	4900	3600	3300	3000	2600	2300	1900	1600	1500	1400
Displacement	ml/r	5335	5108	4937	3632	3291	2951	2610	2270	1930	1646	1532	1362
	in ³ /R	325.5	311.5	301.7	221.6	200.8	180.0	159.2	138.5	117.8	100.4	93.5	83.1
Unit Torque	N.m/Mpa	763	731	706	514	460	419	356	310	259	210	196	168
	lb-ft/PSI	38.91	37.28	36.00	26.21	23.46	21.37	18.16	15.81	13.21	10.71	10.00	8.57
Max. Cont. Speed	r/min	90	105	110	135	145	165	180	215	240	290	315	315
Max. Cont Power	KW	123	123	123	104	97	90	83	76	68	59	54	48
	HP	164.8	164.8	164.8	139.4	129.9	120.6	111.2	101.8	91.1	79.1	72.4	64.3
Max. Top Power	KW	153	153	153	142	136	129	122	112	102	91	87	81
	HP	205.0	205.0	205.0	190.3	182.2	172.9	163.5	150.1	136.7	121.9	116.6	108.5
Max. Cont Pressure	Mpa	21	21	21	21	21	21	21	21	21	21	21	15
	PSI	3045	3045	3045	3045	3045	3045	3045	3045	3045	3045	3045	2175
Max. Top Pressure	Mpa	25	25	25	25	25	25	25	25	25	25	25	15
	PSI	3625	3625	3625	3625	3625	3625	3625	3625	3625	3625	3625	2175

DISPLACEMENT OPTIONS

YSTFD (HD) 325

large displacement: 5300, 5100, 4900

small displacement: 3600, 3300, 3000, 2600, 2300, 1900, 1600, 1500, 1400

FUNCTION SYMBOLS

YSTFD (HD) 325

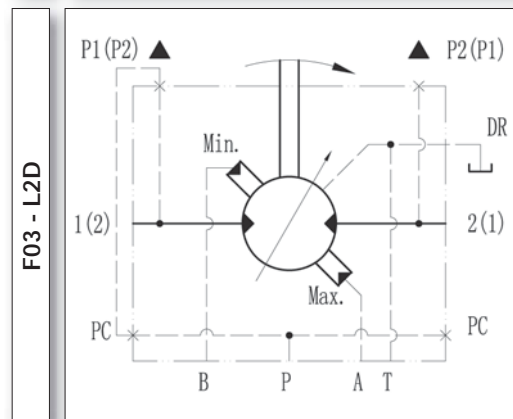
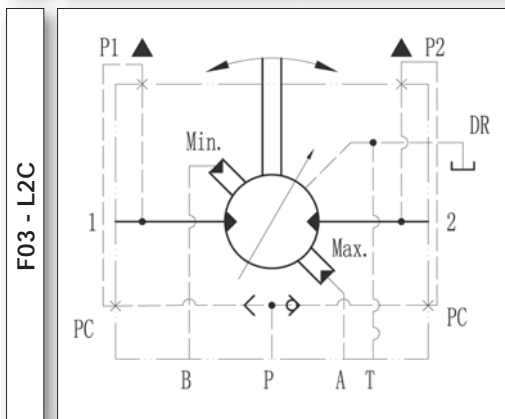
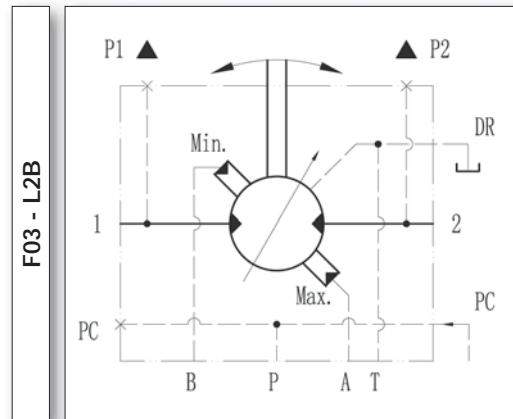
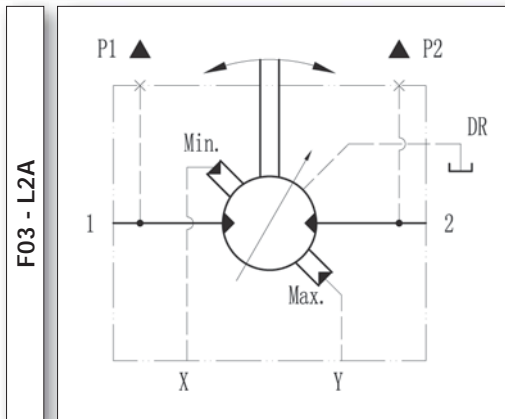

YSTFD (HD) 325

INSTALLATION DIMENSIONS WITH
FO3 DISTRIBUTOR

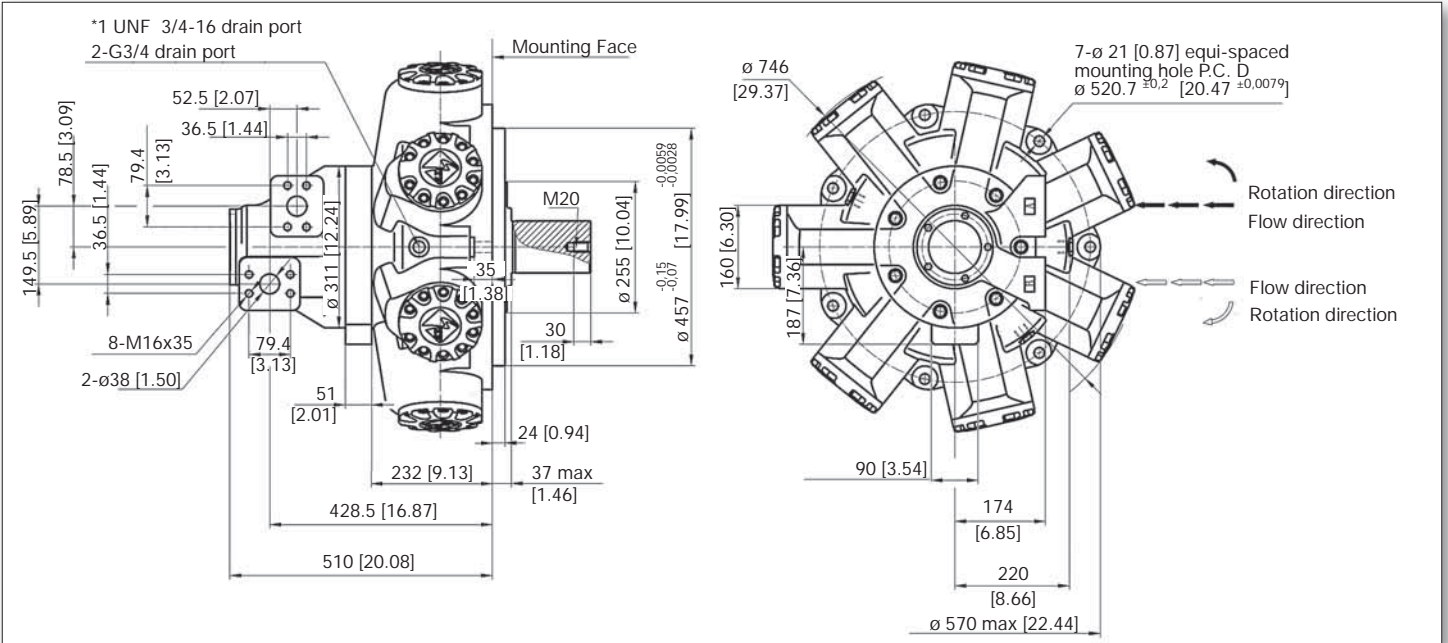

YSTFD (HD) 325

VARIABLE CONTROL MOUNTING DATA

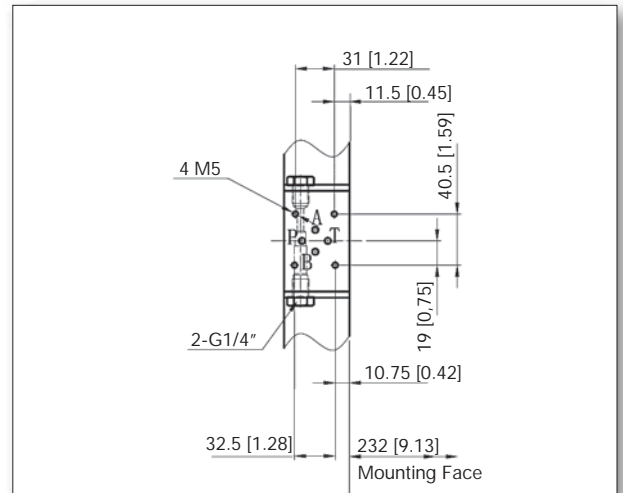
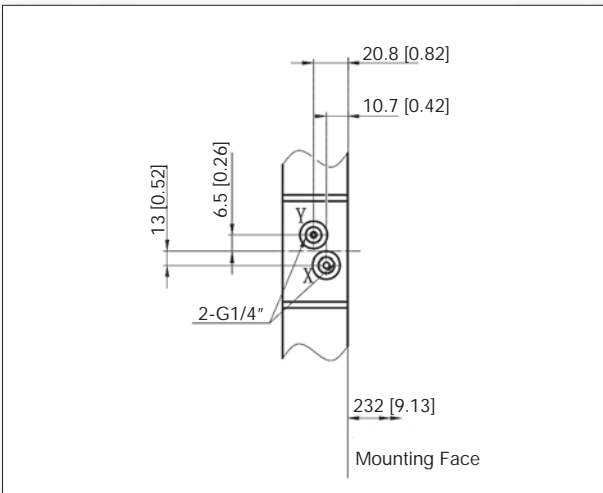

YSTFD

OUTPUT OPTIONS

YSTFD (HD) 325

P71 keyed

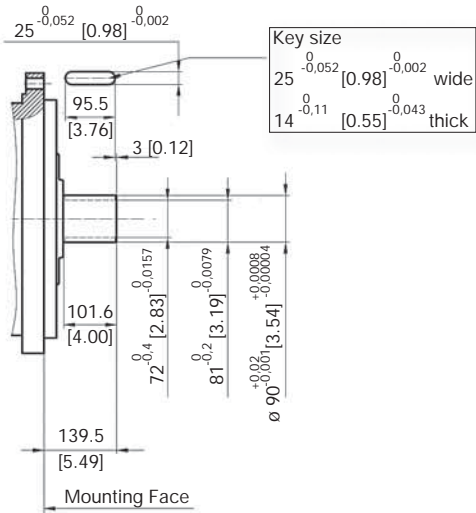

S71 BS 3550 splined

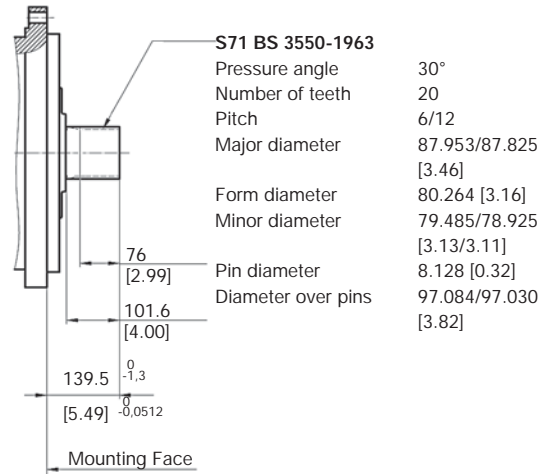

S72 DIN 5480 splined

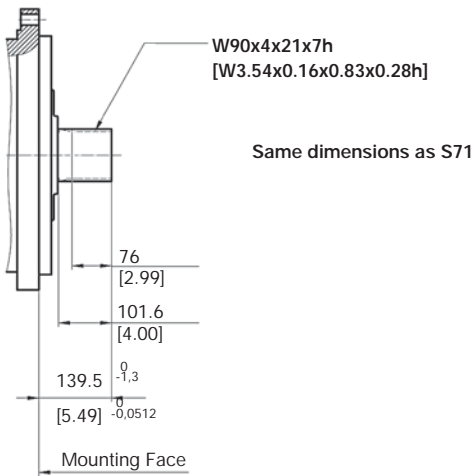

Q71 Female splined

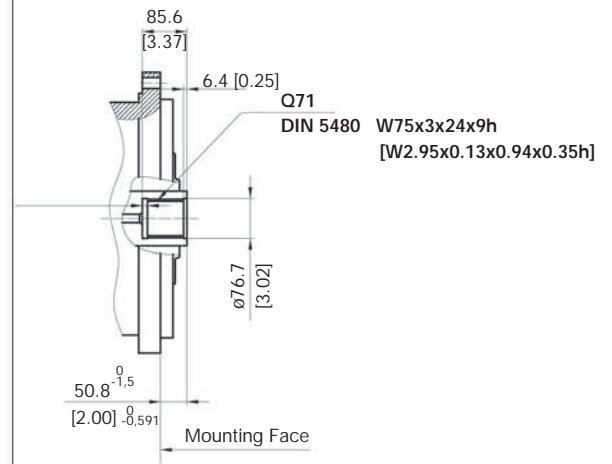

YITM CONTENTS

Technical specifications	page 50
YITM 01	page 52
YITM 02	page 54
YITM 03	page 56
YITM 06	page 58
YITM 08	page 62
YITM 11	page 64
YITM 16	page 68
YITM 31	page 72
YITM 70	page 76
YITM 100	page 78
Distributor Option	page 79
Port Orientation	page 80
Ordering Code	page 81



THE YITM Series motors superior performance and high efficiency come from the roller bearing connection between the piston and the crankshaft. This reduces the friction to a minimum, increase efficiency and speed resulting in longer life.

This series performance is enhanced due to special piston seals, hydraulically balanced Distributor, resulting in high efficiency and smooth consistent output torque.

With 16 frames and a total of 59 displacements the YITM series is one of the largest and most complete series of radial piston motors available on the market today. With displacements from 3.9 CU. to 978 Cu.In/Rev (64 to 16039 CC Rev.) torques from 116 to 34.210 Lf-Ft (189 to 46429 Nm) and speed from 0.3 to 900 RPM this series can deliver the performance required of most applications.

YITM

www.yptius.com

YITM

TECHNICAL SPECIFICATIONS

MAIN SPECIFICATION

TYPE	Displacement		Pressure				Torque				KW	HP	Speed Range	Weight	
	mL/r	in ³ /rev	Rated pressure		Max Pressure		Rated Torque		Unit Torque					r/min	kg
			MPA	PSI	MPA	PSI	N.m	lb/ft	N.m/MPA	lb-ft/PSI					
YITM01-63	64	3.9	20	2900	28	4060	189	139	9	0.46	17	23	15 ~ 900	21	46
YITM01-80	78	4.8	20	2900	28	4060	220	162	11	0.56	19	25	15 ~ 800		
YITM01-100	96	5.9	20	2900	28	4060	280	207	14	0.71	22	29	15 ~ 750		
YITM01-125	126	7.7	16	2320	24	3480	304	224	19	0.97	18	24	15 ~ 600		
YITM01-160	159	9.7	16	2320	24	3480	368	272	23	1.17	17	23	15 ~ 450		
YITM02-100	113	6.9	20	2900	28	4060	330	244	17	0.87	24	32	15 ~ 700	28	67
YITM02-150	159	9.7	20	2900	28	4060	470	347	23	1.17	32	43	15 ~ 650		
YITM02-175	180	11.0	20	2900	24	3480	541	399	27	1.38	33	44	15 ~ 600		
YITM02-200	206	12.6	16	2320	24	3480	489	361	30	1.53	28	38	8 ~ 550		
YITM02-250	235	14.3	16	2320	20	2900	567	418	35	1.78	29	39	8 ~ 500		
YITM02-280	276	16.8	16	2320	20	2900	661	488	41	2.09	31	42	8 ~ 450		
YITM03-175	181	11.0	20	2900	30	4350	550	406	27	1.38	58	78	8 ~ 1000	36	79
YITM03-200	201	12.3	20	2900	30	4350	600	443	30	1.53	48	64	8 ~ 800		
YITM03-250	254	15.5	20	2900	30	4350	761	562	38	1.94	49	66	8 ~ 630		
YITM03-300	289	17.6	20	2900	25	3625	864	638	43	2.19	43	58	6 ~ 500		
YITM03-350	340	20.7	16	2320	25	3625	813	660	50	2.55	33	44	6 ~ 400		
YITM03-400	380	23.2	16	2320	20	2900	901	665	56	2.86	37	50	6 ~ 400		
YITM06-400	397	24.2	20	2900	30	4350	1185	875	59	3.01	61	82	5 ~ 500	58	128
YITM06-450	452	27.6	20	2900	30	4350	1342	990	67	3.42	63	84	5 ~ 450		
YITM06-500	491	30.0	20	2900	25	3625	1463	1080	73	3.72	69	96	5 ~ 450		
YITM06-600	594	36.2	18	2610	22	3190	1775	1310	88	4.49	78	105	4 ~ 420		
YITM06-700	683	41.7	16	2320	20	2900	1616	1193	101	5.15	69	92	4 ~ 400		
YITM06-750	754	46.0	16	2320	20	2900	1760	1299	110	5.61	59	79	4 ~ 320		
YITM08-600	617	37.6	25	3625	32	4640	2282	1684	91	4.64	119	159	4 ~ 500	72	158
YITM08-700	710	43.3	25	3625	32	4640	2626	1938	105	5.35	110	147	4 ~ 400		
YITM08-800	810	49.4	20	2900	25	3625	2396	1768	119	6.07	100	134	4 ~ 400		
YITM08-900	889	54.2	20	2900	25	3625	2629	1940	131	6.68	94	126	3 ~ 350		
YITM08-1000	1000	61.0	16	2320	20	2900	2366	1746	147	7.50	74	99	3 ~ 300		

YITM

TECHNICAL SPECIFICATIONS

YITM

MAIN SPECIFICATION

TYPE	Displacement		Pressure				Torque				KW	HP	Speed Range	Weight	
	mL/r	in ³ /rev	Rated pressure		Max Pressure		Rated Torque		Unit Torque					r/min	kg
			MPA	PSI	MPA	PSI	N.m	lb/ft	N.m/MPA	lb-ft/PSI					
YITM11-700	682	41.6	25	3625	30	4350	2511	1853	100	5.10	105	141	4 ~ 400	95	209
YITM11-800	782	47.7	25	3625	30	4350	2903	2142	116	5.91	121	162	4 ~ 400		
YITM11-900	894	54.5	25	3625	30	4350	3311	2444	132	6.73	138	185	4 ~ 400		
YITM11-1000	981	59.9	20	2900	25	3625	2917	2153	145	7.39	95	127	3 ~ 320		
YITM11-1100	1104	67.4	20	2900	25	3625	3308	2441	165	8.41	111	149	3 ~ 320		
YITM11-1200	1234	75.3	20	2900	25	3625	3657	2699	182	9.28	119	159	3 ~ 320		
YITM11-1300	1301	79.4	16	2320	20	2900	3080	2273	192	9.79	80	107	3 ~ 250		
YITM16-1400	1413	86.2	20	2900	30	4350	4191	3093	210	10.71	175	235	2 ~ 400	170	374
YITM16-1600	1648	100.5	20	2900	30	4350	4881	3602	244	12.44	197	264	2 ~ 400		
YITM16-1800	1814	110.7	18	2610	25	3625	4870	3594	268	13.69	161	216	2 ~ 320		
YITM16-2000	2034	124.1	16	2320	25	3625	4826	3562	301	15.35	157	210	2 ~ 320		
YITM16-2400	2267	138.3	16	2320	20	2900	5374	3966	335	17.08	137	184	2 ~ 250		
YITM31-2500	2553	155.7	25	3625	32	4640	9523	7028	380	19.38	249	334	2 ~ 250	298	656
YITM31-2800	2683	163.7	25	3625	32	4640	10049	7416	401	20.45	207	277	1 ~ 200		
YITM31-3000	3063	186.9	20	2900	25	3625	9189	6782	459	23.41	191	256	1 ~ 200		
YITM31-3150	3218	196.3	20	2900	25	3625	9601	7086	480	24.48	196	263	1 ~ 200		
YITM31-3500	3462	211.2	20	2900	25	3625	10220	7542	511	26.06	171	229	1 ~ 160		
YITM31-4000	4152	253.3	20	2900	25	3625	12481	9211	624	31.82	205	275	1 ~ 160		
YITM31-5000	4828	294.6	16	2320	20	2900	11449	8449	715	36.46	187	251	1 ~ 160		
YITM70-5000	4946	301.8	20	2900	25	3625	14626	10794	731	37.28	220	295	1 ~ 160	550	1210
YITM70-5400	5452	332.6	20	2900	25	3625	16125	11900	806	41.10	243	326	1 ~ 160		
YITM70-6000	5984	365.1	20	2900	25	3625	17697	13061	885	45.13	208	279	0.5 ~ 125		
YITM70-6300	6540	399.0	18	2610	22.5	3262	17408	12847	967	49.32	205	275	0.5 ~ 125		
YITM70-7000	7122	434.5	16	2320	20	2900	16849	14649	1053	53.70	198	265	0.5 ~ 125		
YITM100-6300	6758	412.3	20	2900	25	3625	19340	14273	967	49.32	226	303	0.5 ~ 125	830	1826
YITM100-7000	7390	450.8	20	2900	25	3625	21160	15616	1058	53.96	248	332	0.5 ~ 125		
YITM100-8000	7985	487.2	20	2900	25	3625	22896	16897	1145	58.39	269	360	0.5 ~ 125		
YITM100-9000	8636	526.9	20	2900	25	3625	24740	18258	1237	63.09	290	389	0.5 ~ 125		
YITM100-10000	10016	611.1	18	2610	25	3625	25758	19010	1431	72.98	245	328	0.5 ~ 100		
YITM160-12500	13333	813.5	20	2900	25	3625	39460	29122	1973	100.62	331	444	0.3 ~ 80	1000	2200
YITM160-16000	16039	978.6	20	2900	25	3625	46420	34258	2321	118.37	306	410	0.3 ~ 80		

YITM

YITM O1

YITM O1

TECHNICAL SPECIFICATIONS

TYPE	Displacement		Pressure				Torque				KW	HP	Speed Range r/min	Weight	
	mL/r	in ³ /rev	Rated pressure		Max Pressure		Rated Torque		Unit Torque					kg	lbs
			MPA	PSI	MPA	PSI	N.m	lb/ft	N.m/MPA	lb-ft/PSI					
YITM01-63	64	3.9	20	2900	28	4060	189	139	9	0.46	17	23	15 ~ 900	21	46
YITM01-80	78	4.8	20	2900	28	4060	220	162	11	0.56	19	25	15 ~ 800		
YITM01-100	96	5.9	20	2900	28	4060	280	207	14	0.71	22	29	15 ~ 750		
YITM01-125	126	7.7	16	2320	24	3480	304	224	19	0.97	18	24	15 ~ 600		
YITM01-160	159	9.7	16	2320	24	3480	368	272	23	1.17	17	23	15 ~ 450		

YITM O1

INSTALLATION DIMENSIONS

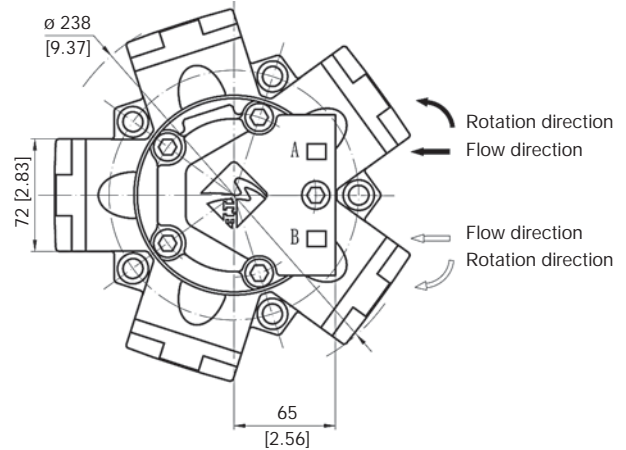
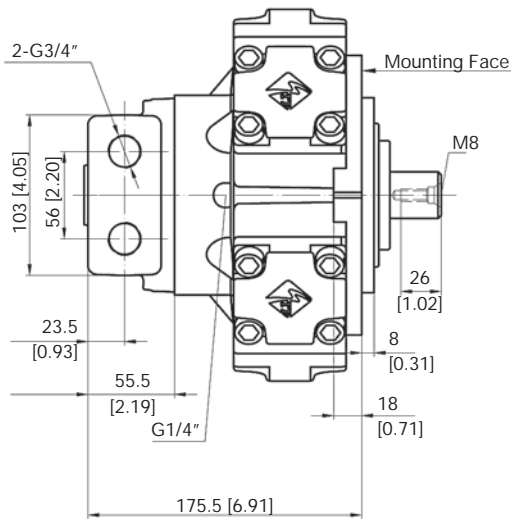

YITM O1

OUTPUT OPTIONS

P101 1" parallel key

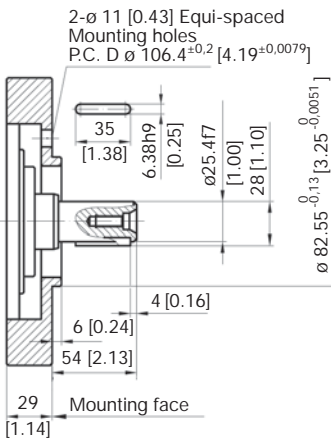

P102 35 mm parallel key

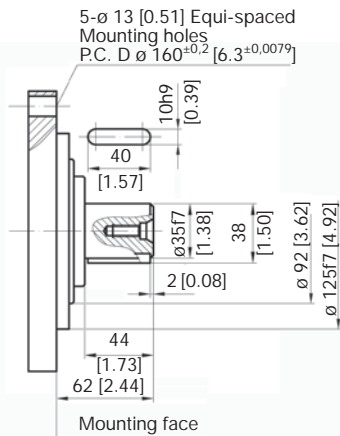

YITM O1

P1O3 25 mm parallel key

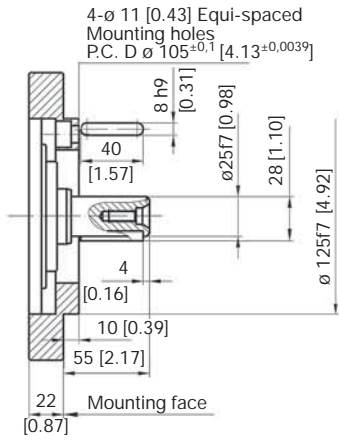

OUTPUT OPTIONS

P1O4 35 mm parallel key

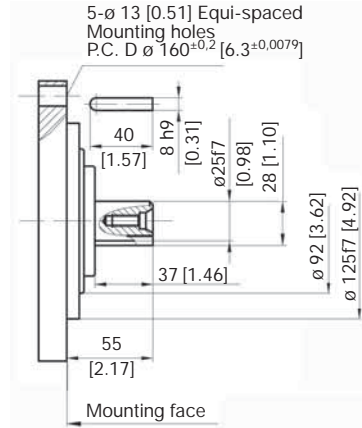

S1O5 6-30b12x25bx12x6f8 involute spline

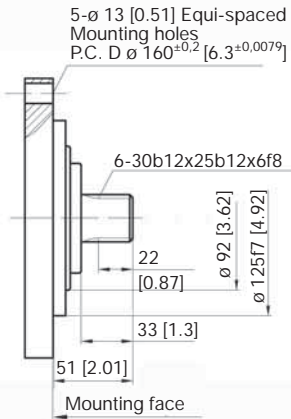

YITM O2

YITM O2

TECHNICAL SPECIFICATIONS

TYPE	Displacement		Pressure				Torque				KW	HP	Speed Range r/min	Weight	
	mL/r	in ³ /rev	Rated pressure		Max Pressure		Rated Torque		Unit Torque					kg	lbs
			MPA	PSI	MPA	PSI	N.m	lb/ft	N.m/MPa	lb-ft/PSI					
YITM02-100	113	6.9	20	2900	28	4060	330	244	17	0.87	24	32	15 ~ 700	28	67
YITM02-150	159	9.7	20	2900	28	4060	470	347	23	1.17	32	43	15 ~ 650		
YITM02-175	180	11.0	20	2900	24	3480	541	399	27	1.38	33	44	15 ~ 600		
YITM02-200	206	12.6	16	2320	24	3480	489	361	30	1.53	28	38	8 ~ 550		
YITM02-250	235	14.3	16	2320	20	2900	567	418	35	1.78	29	39	8 ~ 500		
YITM02-280	276	16.8	16	2320	20	2900	661	488	41	2.09	31	42	8 ~ 450		

YITM O2

INSTALLATION DIMENSIONS

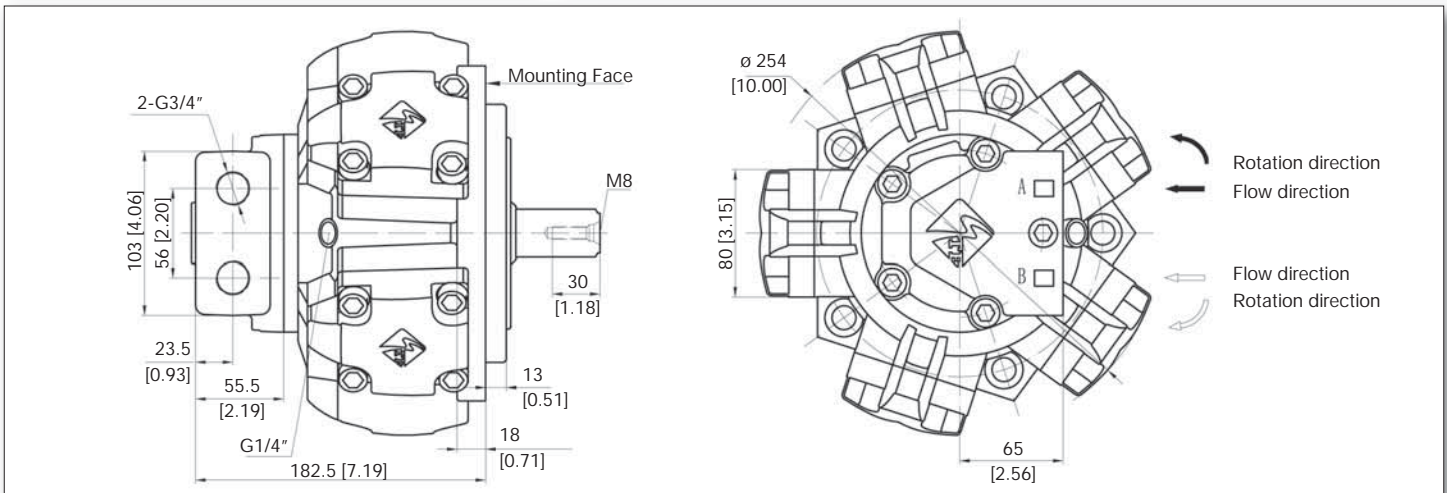

YITM O2

OUTPUT OPTIONS

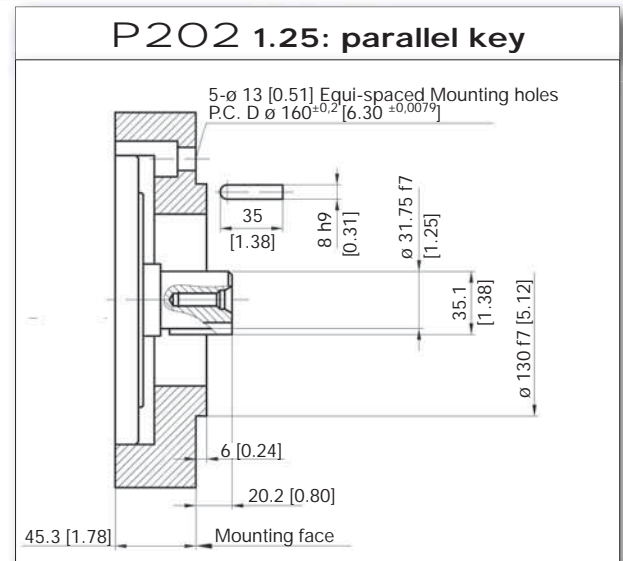
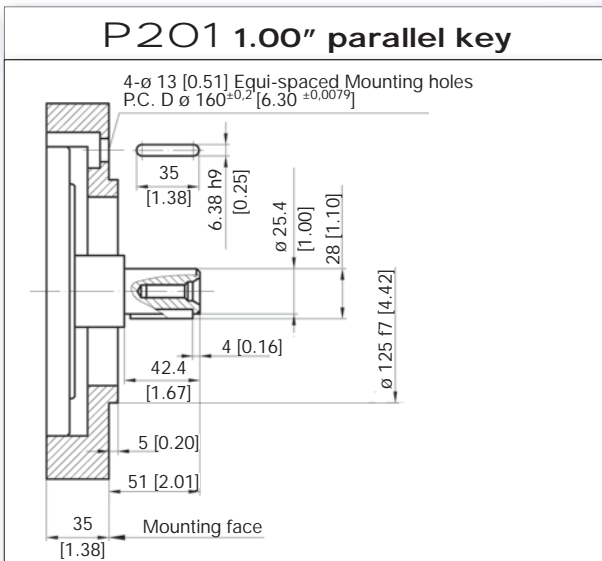

YITM O2

OUTPUT OPTIONS

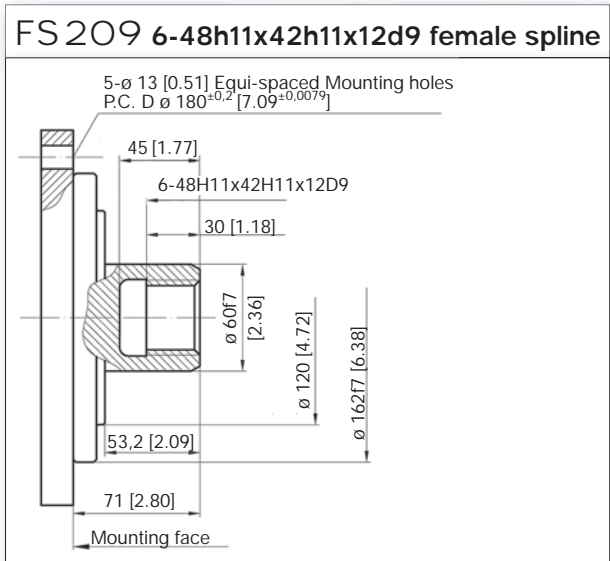
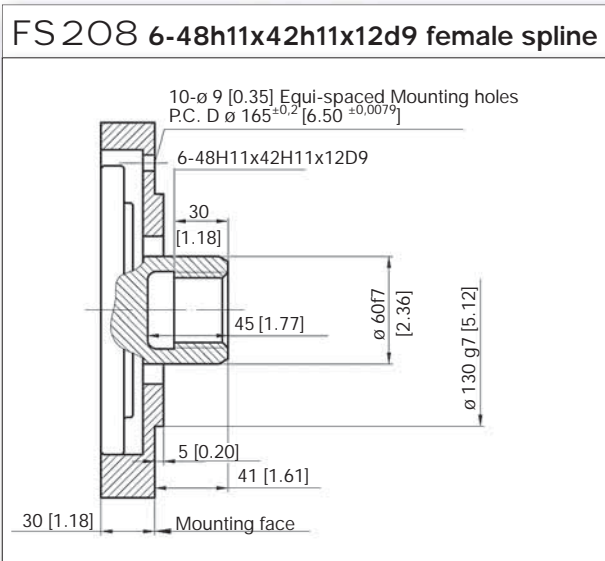
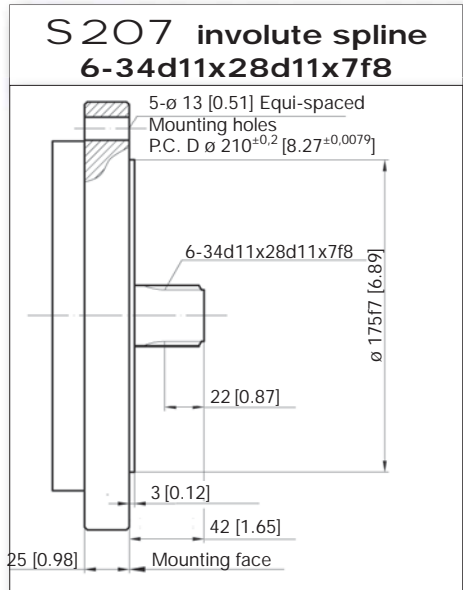
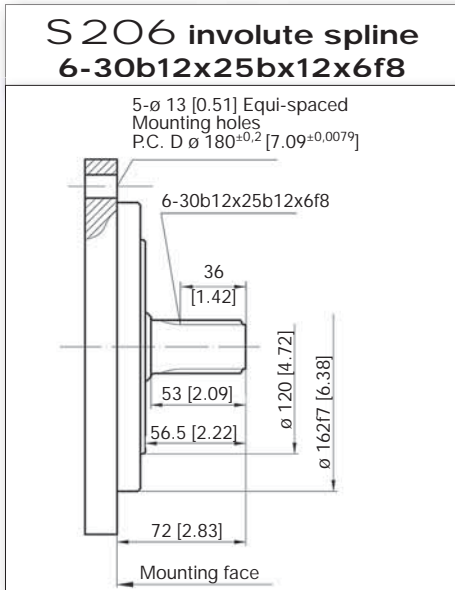
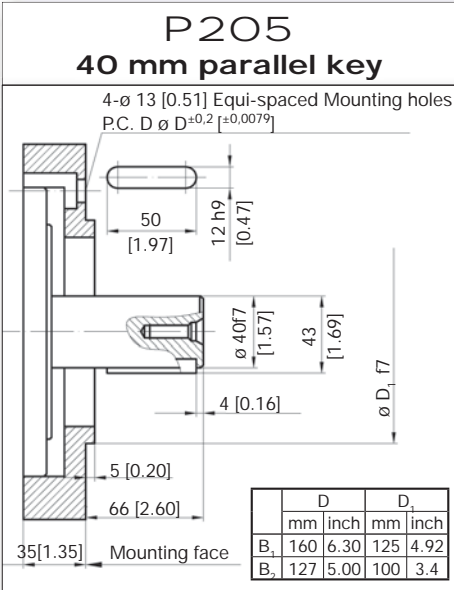
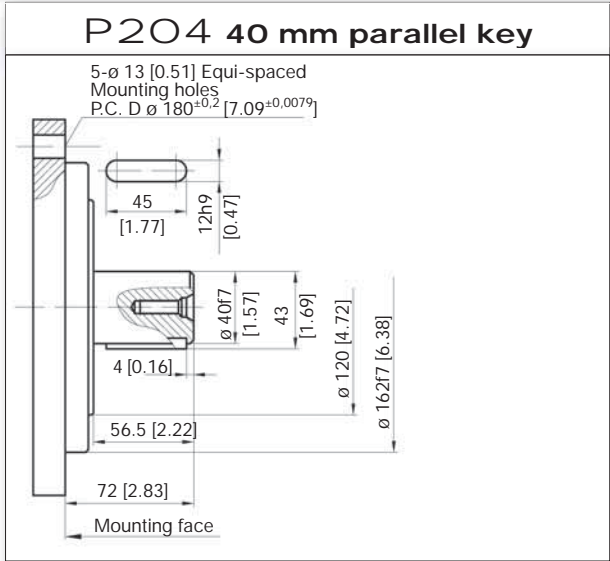
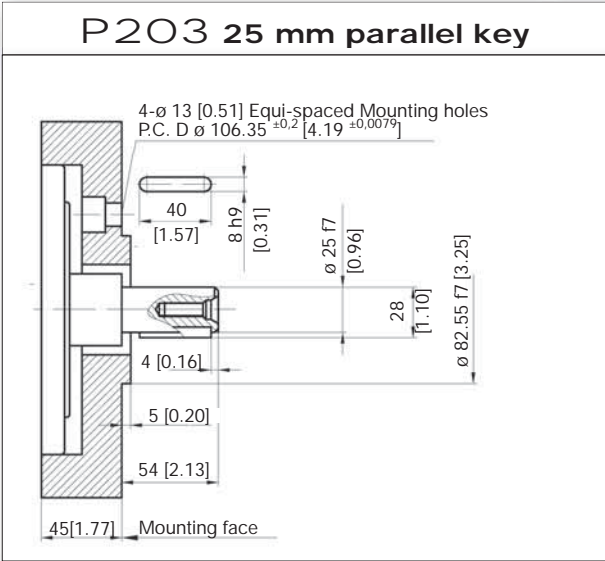

YITM O3

YITM O3

TECHNICAL SPECIFICATIONS

TYPE	Displacement		Pressure				Torque				KW	HP	Speed Range	Weight	
	mL/r	in ³ /rev	Rated pressure		Max Pressure		Rated Torque		Unit Torque					r/min	kg
			MPa	PSI	MPa	PSI	N.m	lb/ft	N.m/MPa	lb-ft/PSI					
YITM03-175	181	11.0	20	2900	30	4350	550	406	27	1.38	58	78	8 ~ 1000	36	79
YITM03-200	201	12.3	20	2900	30	4350	600	443	30	1.53	48	64	8 ~ 800		
YITM03-250	254	15.5	20	2900	30	4350	761	562	38	1.94	49	66	8 ~ 630		
YITM03-300	289	17.6	20	2900	25	3625	864	638	43	2.19	43	58	6 ~ 500		
YITM03-350	340	20.7	16	2320	25	3625	813	660	50	2.55	33	44	6 ~ 400		
YITM03-400	380	23.2	16	2320	20	2900	901	665	56	2.86	37	50	6 ~ 400		

YITM O3

INSTALLATION DIMENSIONS

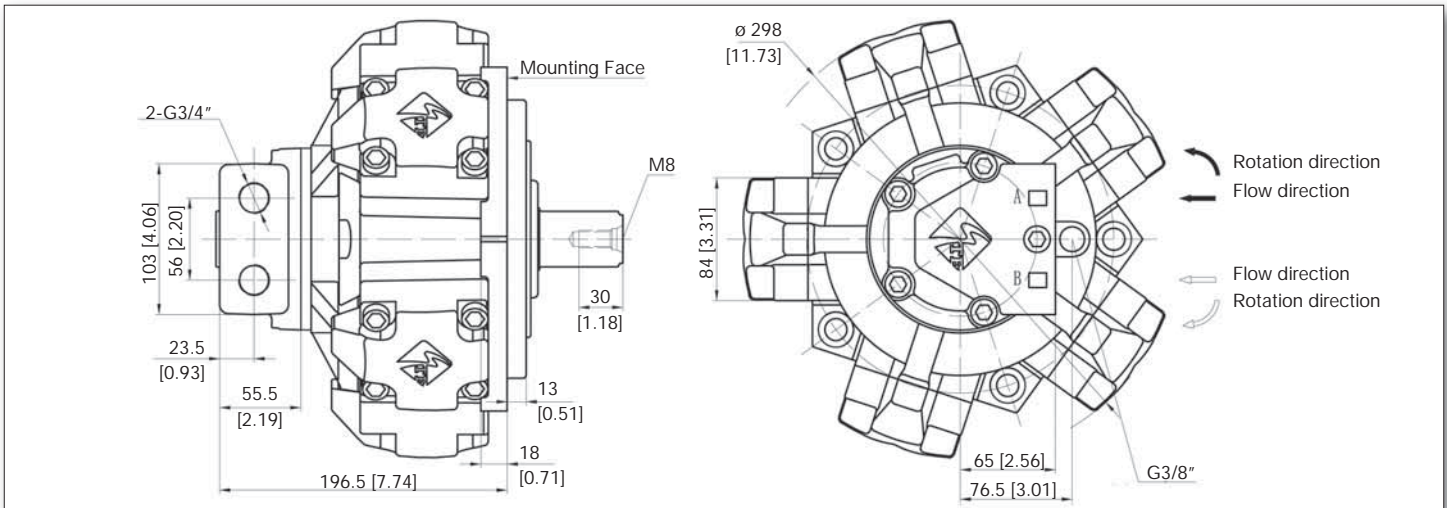

YITM O3

OUTPUT OPTIONS

P301 38 mm parallel key

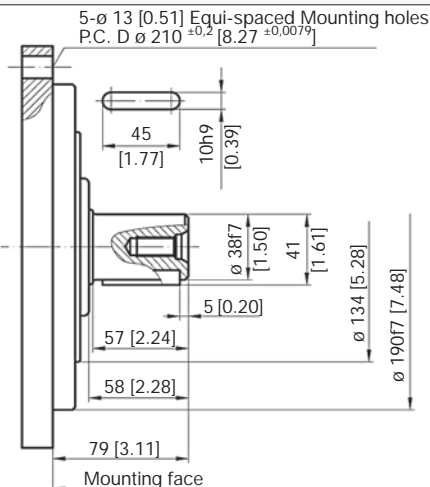

P302 40 mm parallel key

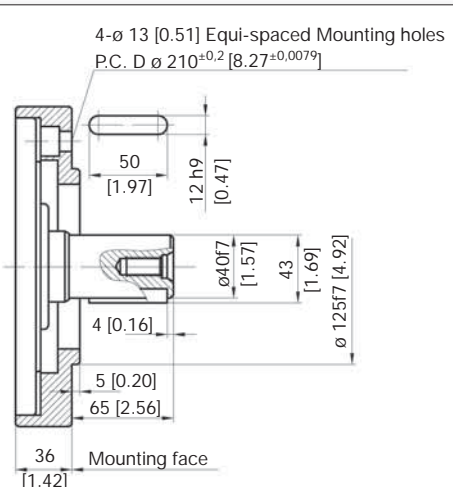

YITM 03

OUTPUT OPTIONS

P303 40 mm parallel key

4- \varnothing 13 [0.51] Equi-spaced Mounting holes
P.C. D \varnothing 160 ± 0.2 [6.30 ± 0.0079]

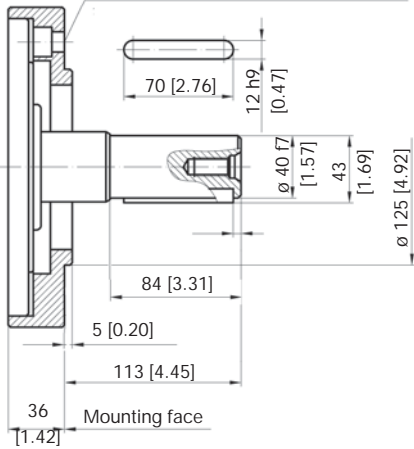

P304 50 mm parallel key

2- \varnothing 17 [0.67] Equi-spaced Mounting holes
P.C. D \varnothing 200 ± 0.2 [7.87 ± 0.0079]

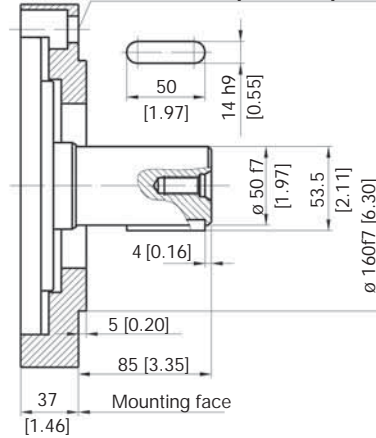

S 305 8-40d11x36d11x7f8

5- \varnothing 13 [0.51] Equi-spaced Mounting holes
P.C. D \varnothing 195 ± 0.2 [7.68 ± 0.0079]

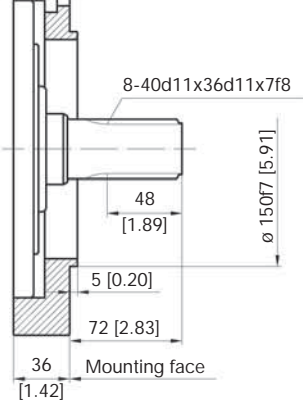

S 306 8-38b12x32b12x6f8

5- \varnothing 13 [0.51] Equi-spaced Mounting holes
P.C. D \varnothing 210 ± 0.2 [8.27 ± 0.0079]

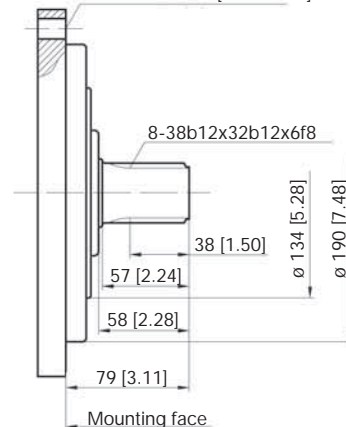

S 307 6-34d11x28d11x7f8

5- \varnothing 13 [0.51] Equi-spaced Mounting holes
P.C. D \varnothing 210 ± 0.2 [8.27 ± 0.0079]

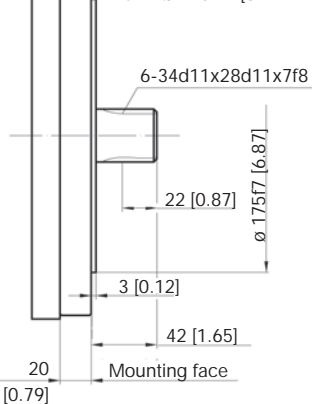

FS 308 female spline 6-48h11x42h11x12d9

10- \varnothing 11 [0.43] Equi-spaced Mounting holes
P.C. D \varnothing 220 ± 0.2 [8.66 ± 0.0079]

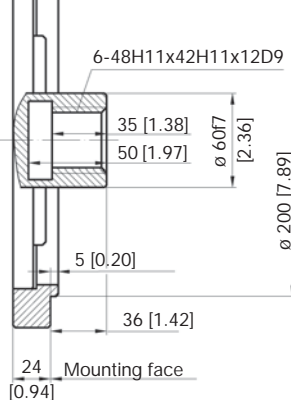

FS 309 female spline 6-48h11x42h11x12d9

5- \varnothing 13 [0.51] Equi-spaced Mounting holes
P.C. D \varnothing 210 ± 0.2 [8.27 ± 0.0079]

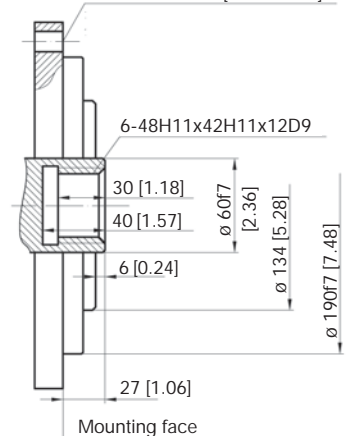

YITM 06

YITM 06

TECHNICAL SPECIFICATIONS

TYPE	Displacement		Pressure				Torque				KW	HP	Speed Range r/min	Weight	
	mL/r	in ³ /rev	Rated pressure		Max Pressure		Rated Torque		Unit Torque					kg	lbs
			MPA	PSI	MPA	PSI	N.m	lb/ft	N.m/MPA	lb-ft/PSI					
YITM06-400	397	24.2	20	2900	30	4350	1185	875	59	3.01	61	82	5 ~ 500	58	128
YITM06-450	452	27.6	20	2900	30	4350	1342	990	67	3.42	63	84	5 ~ 450		
YITM06-500	491	30.0	20	2900	25	3625	1463	1080	73	3.72	69	96	5 ~ 450		
YITM06-600	594	36.2	18	2610	22	3190	1775	1310	88	4.49	78	105	4 ~ 420		
YITM06-700	683	41.7	16	2320	20	2900	1616	1193	101	5.15	69	92	4 ~ 400		
YITM06-750	754	46.0	16	2320	20	2900	1760	1299	110	5.61	59	79	4 ~ 320		

YITM 06

INSTALLATION DIMENSIONS

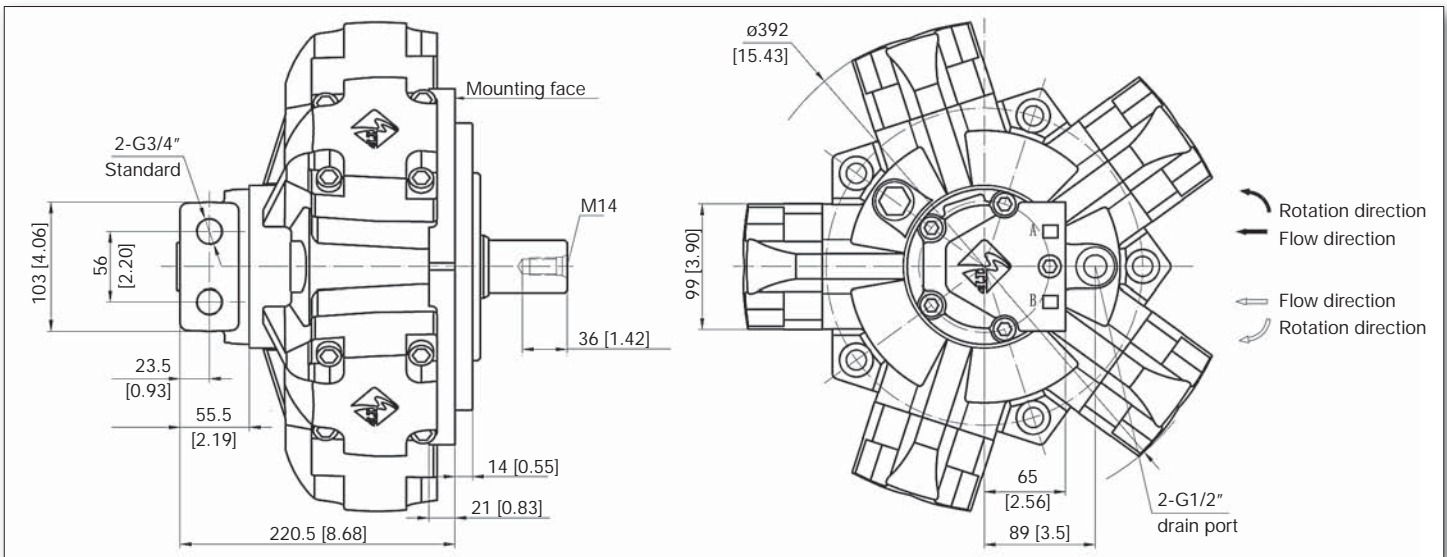

YITM 06

OUTPUT OPTIONS

P601 42 mm parallel key

5- ϕ 16 [0.63] Equi-spaced Mounting holes
P.C. D ϕ 254^{+0.2} [10^{+0.0079}]

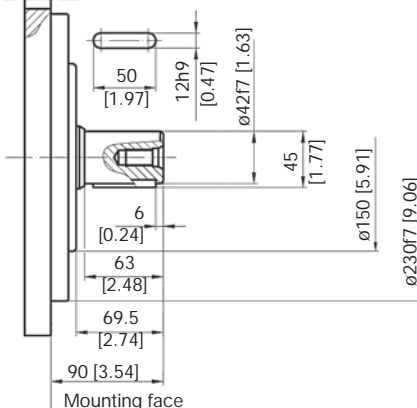

P602 50 mm parallel key

4- ϕ 17 [0.67] Equi-spaced Mounting holes
P.C. D ϕ 200^{+0.2} [7.87^{+0.0079}]

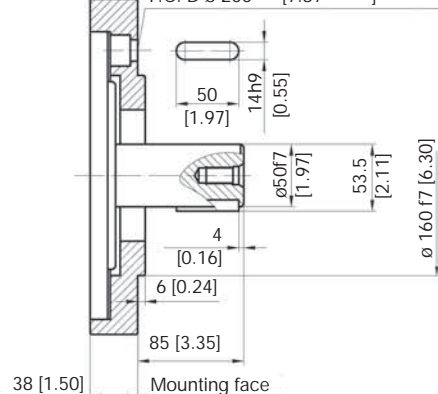

YITM 06

OUTPUT OPTIONS

P603 50 mm parallel key

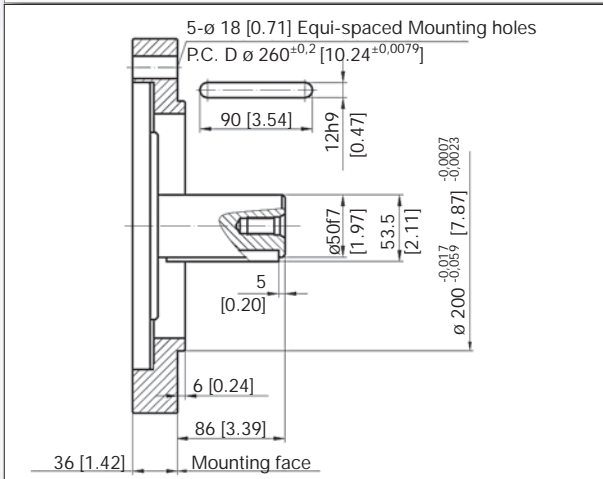

P604 50 mm parallel key

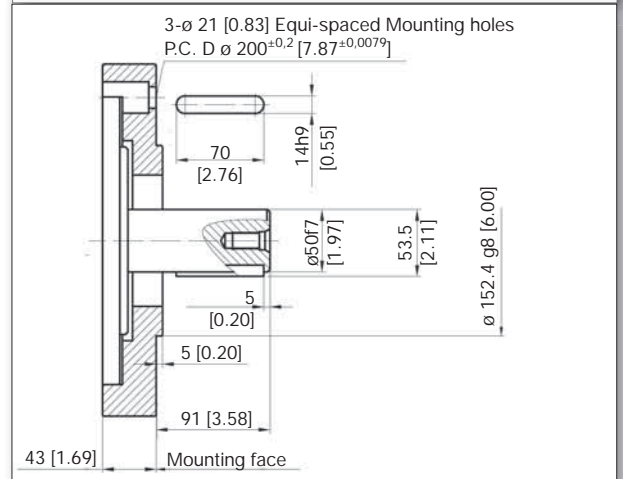

S606 8-40d11x36d11x7f8

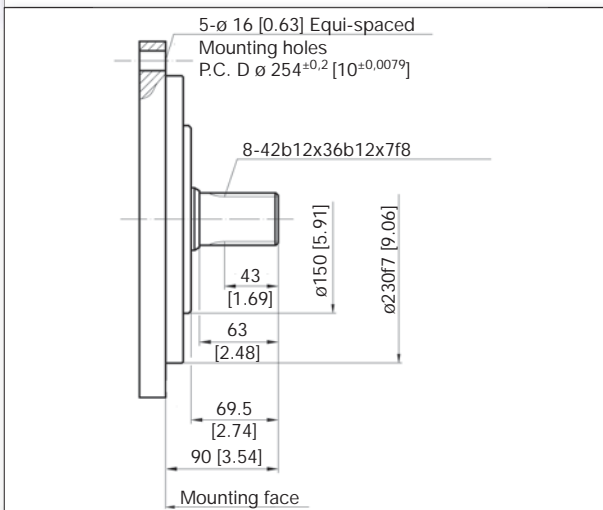

S605 8-42b12x36b12x7f8

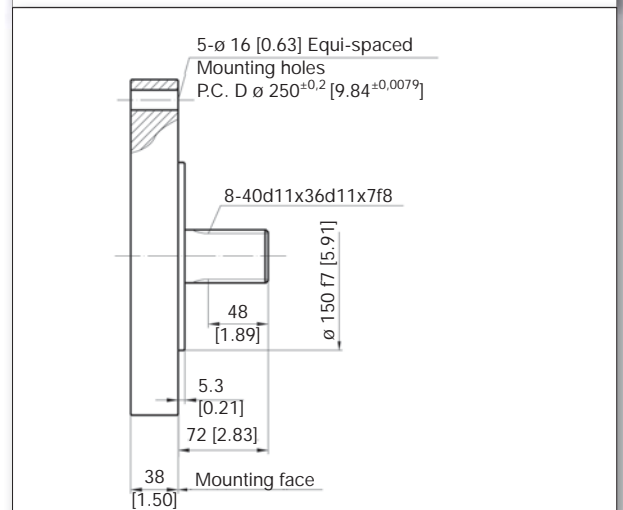

S607 8-54d11x46g7x9f8

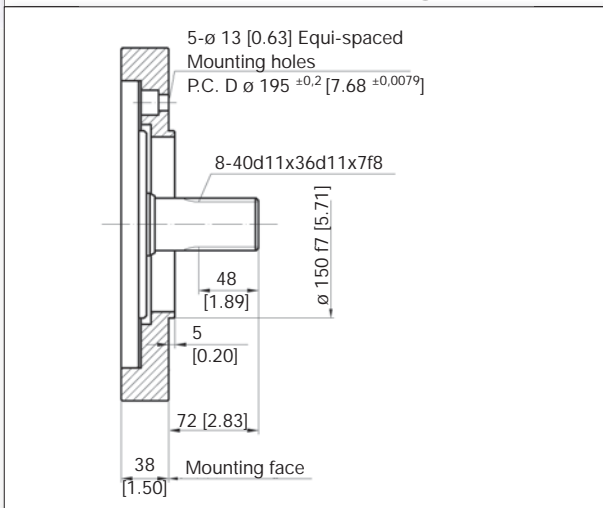

S608 8-54d11x46g7x9f8

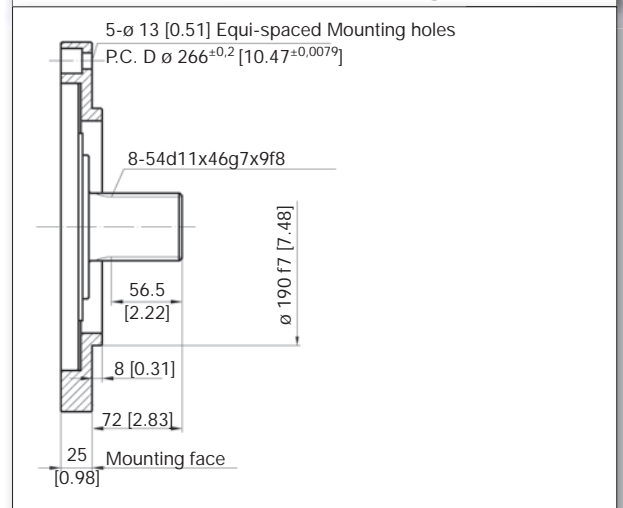

YITM

YITM 06

S609 8-60b12x52b12x9f8

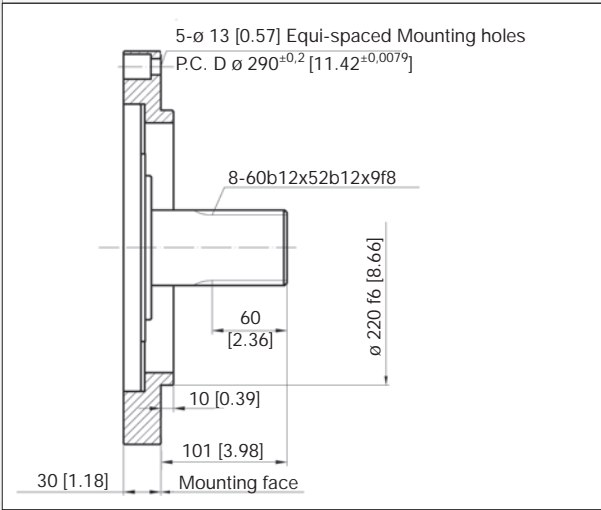

OUTPUT OPTIONS

FS610 6-55h11x50h11x14d9 female spline

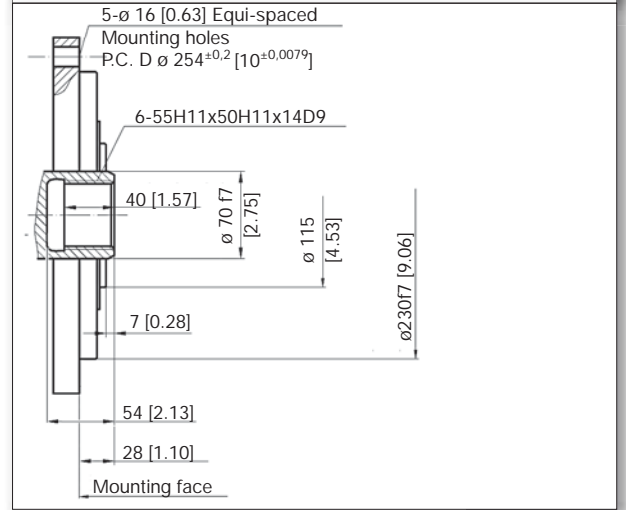

FS611 6-7-h11x62h16d9 female spline

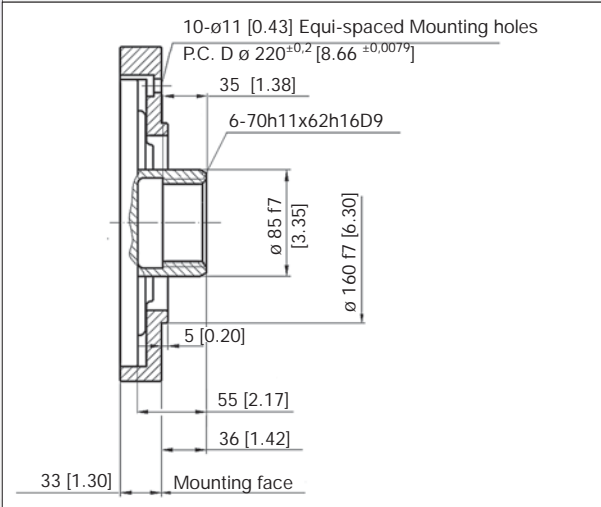

TESTING



Rigorous testing of new products and production guarantees our customers products of the highest quality. Our products are tested 100% prior to shipping.

YITM 08

YITM 08

TECHNICAL SPECIFICATIONS

TYPE	Displacement		Pressure				Torque				KW	HP	Speed Range r/min	Weight	
	mL/r	in ³ /rev	Rated pressure		Max Pressure		Rated Torque		Unit Torque					kg	lbs
			MPA	PSI	MPA	PSI	N.m	lb/ft	N.m/MPA	lb-ft/PSI					
YITM08-600	617	37.6	25	3625	32	4640	2282	1684	91	4.64	119	159	4 ~ 500	72	158
YITM08-700	710	43.3	25	3625	32	4640	2626	1938	105	5.35	110	147	4 ~ 400		
YITM08-800	810	49.4	20	2900	25	3625	2396	1768	119	6.07	100	134	4 ~ 400		
YITM08-900	889	54.2	20	2900	25	3625	2629	1940	131	6.68	94	126	3 ~ 350		
YITM08-1000	1000	61.0	16	2320	20	2900	2366	1746	147	7.50	74	99	3 ~ 300		

YITM 08

INSTALLATION DIMENSIONS

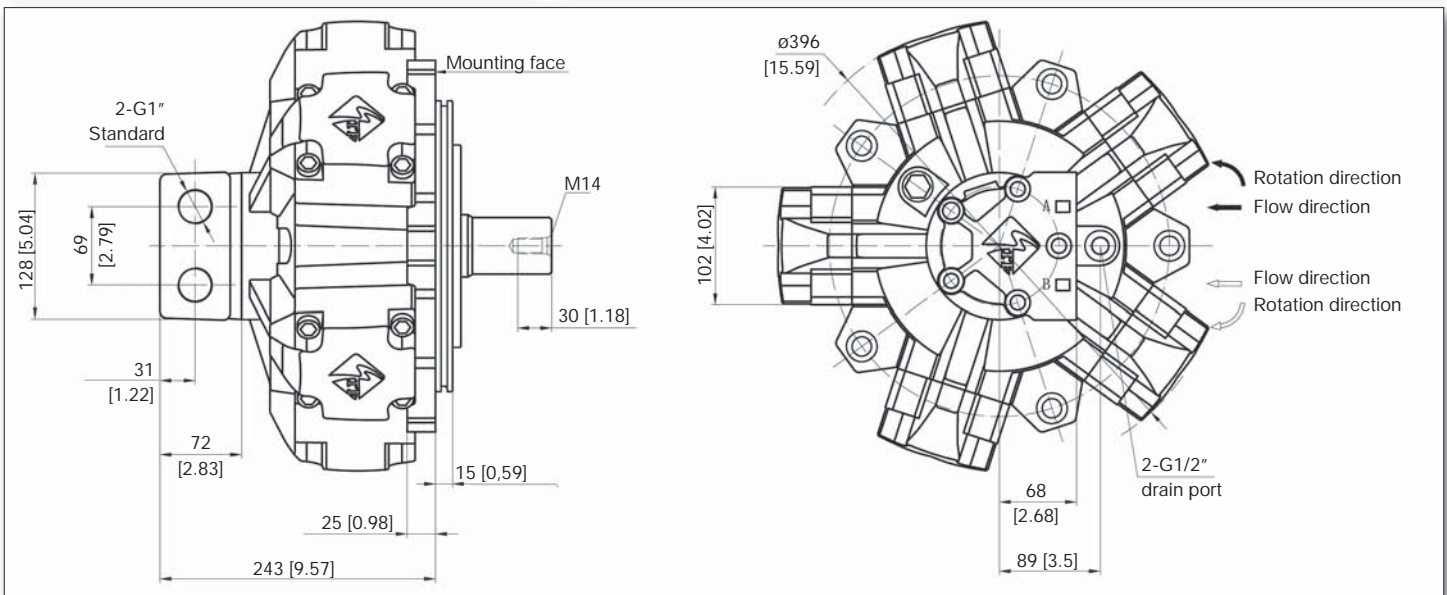

YITM 08

OUTPUT OPTIONS

P801 42 mm parallel key

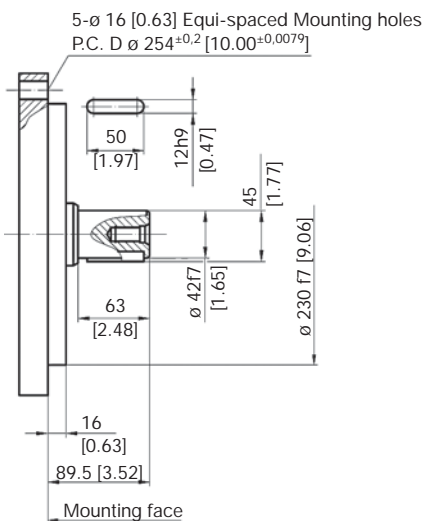

P802 54 mm parallel key

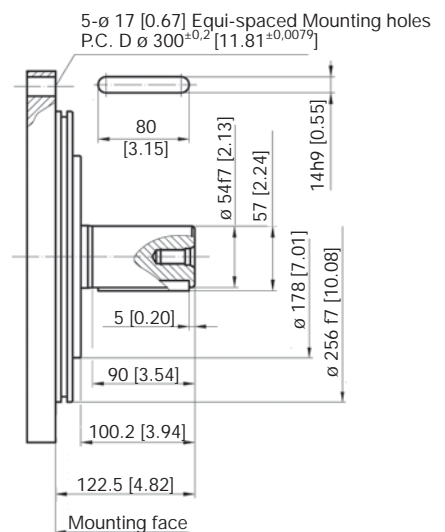

YITM 08

OUTPUT OPTIONS

S803 8-42b12x36b12x7f8

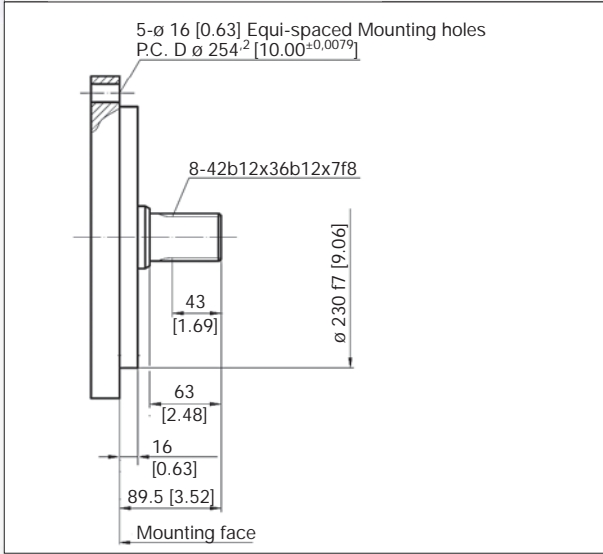

S804 8-50b12x46b12x9f8

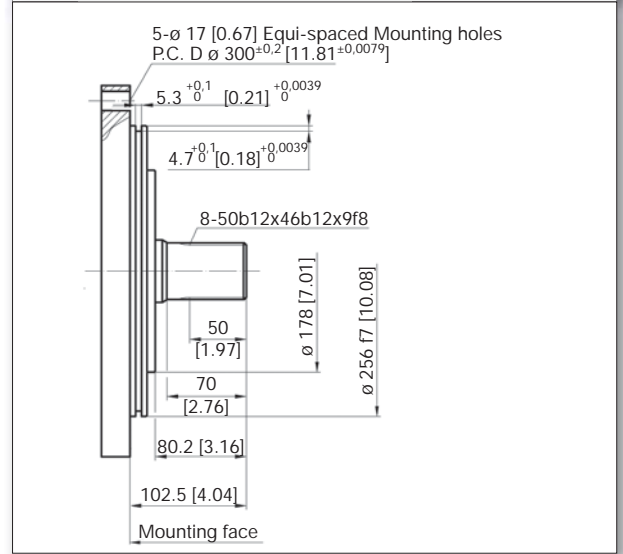

YITM

YITM 11

YITM 11

TECHNICAL SPECIFICATIONS

TYPE	Displacement		Pressure				Torque				KW	HP	Speed Range r/min	Weight	
	mL/r	in ³ /rev	Rated pressure		Max Pressure		Rated Torque		Unit Torque					kg	lbs
			MPA	PSI	MPA	PSI	N.m	lb/ft	N.m/MPA	lb-ft/PSI					
YITM11-700	682	41.6	25	3625	30	4350	2511	1853	100	5.10	105	141	4 ~ 400	95	209
YITM11-800	782	47.7	25	3625	30	4350	2903	2142	116	5.91	121	162	4 ~ 400		
YITM11-900	894	54.5	25	3625	30	4350	3311	2444	132	6.73	138	185	4 ~ 400		
YITM11-1000	981	59.9	20	2900	25	3625	2917	2153	145	7.39	95	127	3 ~ 320		
YITM11-1100	1104	67.4	20	2900	25	3625	3308	2441	165	8.41	111	149	3 ~ 320		
YITM11-1200	1234	75.3	20	2900	25	3625	3657	2699	182	9.28	119	159	3 ~ 320		
YITM11-1300	1301	79.4	16	2320	20	2900	3080	2273	192	9.79	80	107	3 ~ 250		

YITM 11

INSTALLATION DIMENSIONS

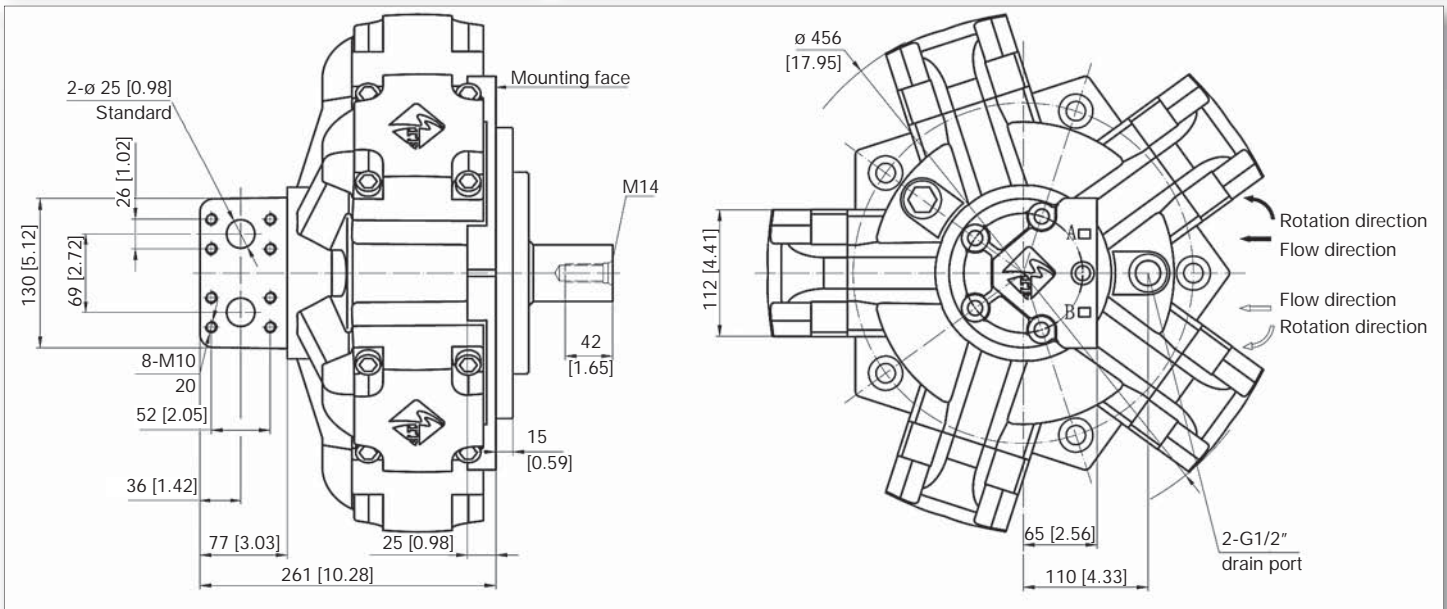

YITM 11

OUTPUT OPTIONS

P1101 50 mm parallel key

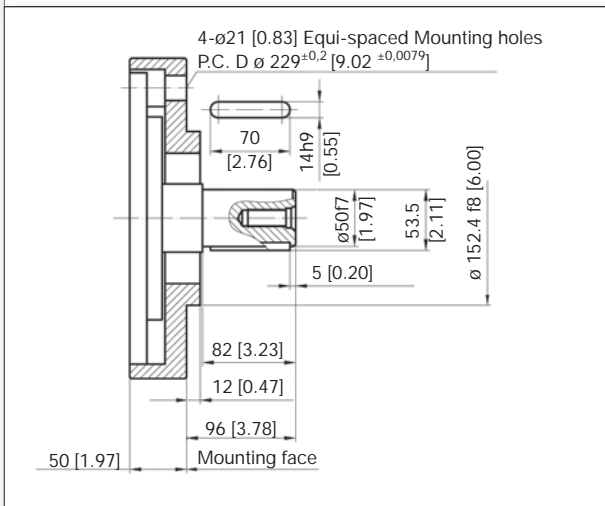

P1102 54 mm parallel key

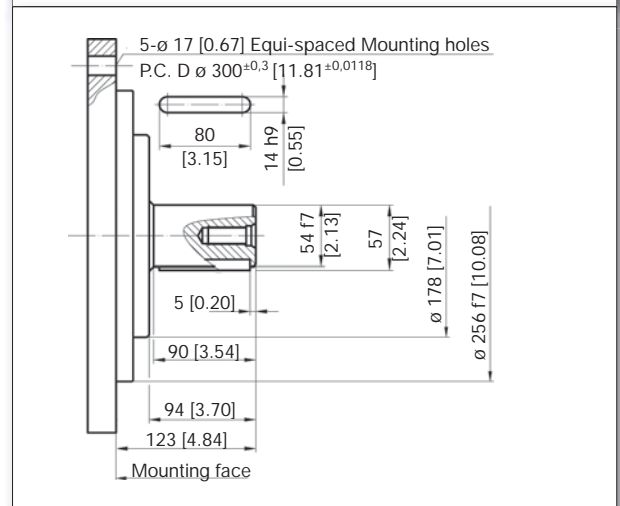

YITM 11

OUTPUT OPTIONS

P1103 60 mm parallel shaft

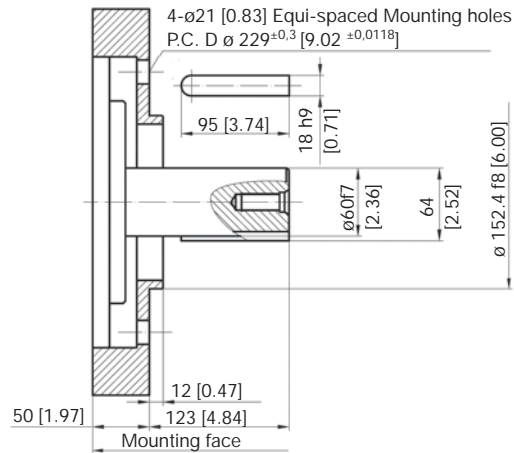

S1104 8-40d11x36d11x7f8

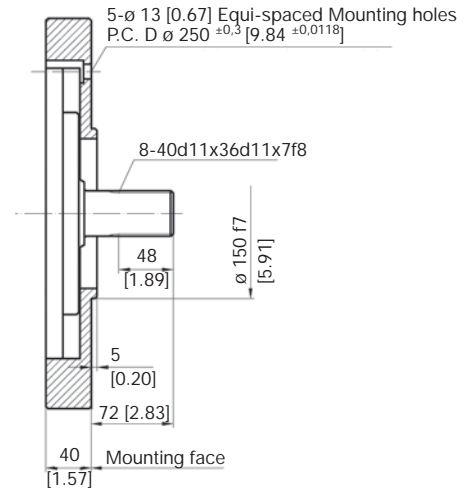

S1105 8-42b12x36b12x7f8

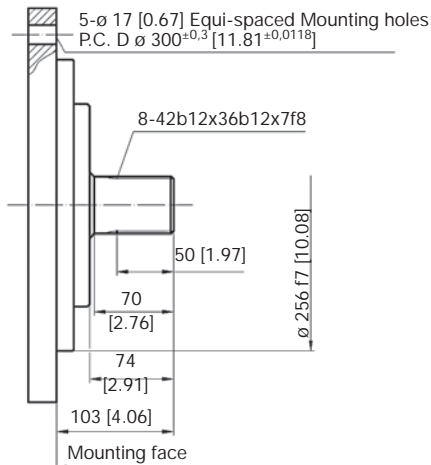

S1106 8-60b12x52b12x12f8

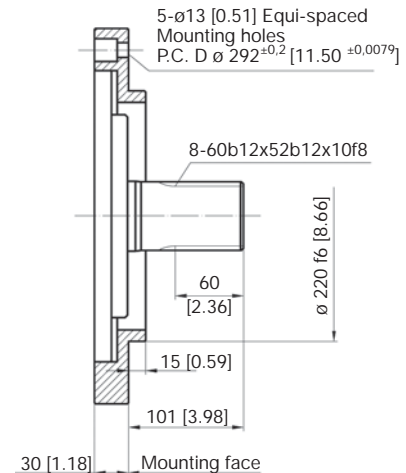

S1107 8-65d11x56d11x10f8

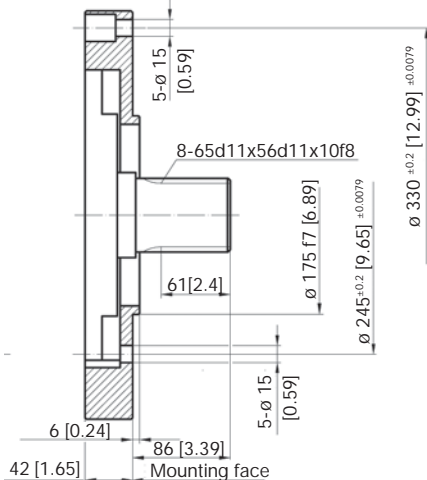

S1108 8-65d11x56d11x10f8

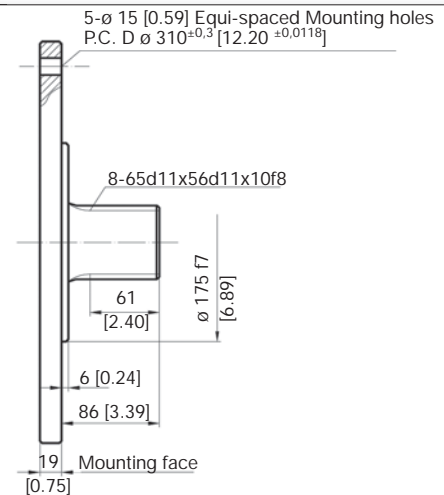

YITM 11

S1109 8-65d11x56d11x10f8

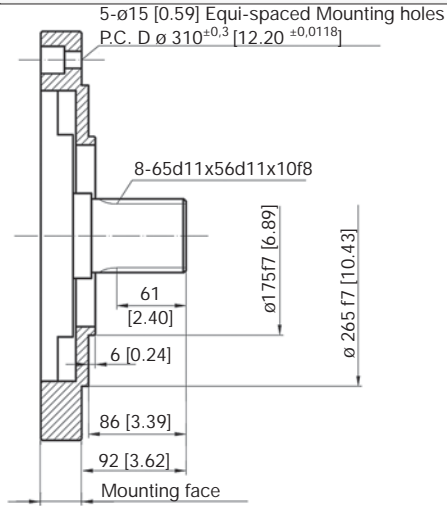

OUTPUT OPTIONS

FS1110 6-90h11x80h11x20d9 female spline

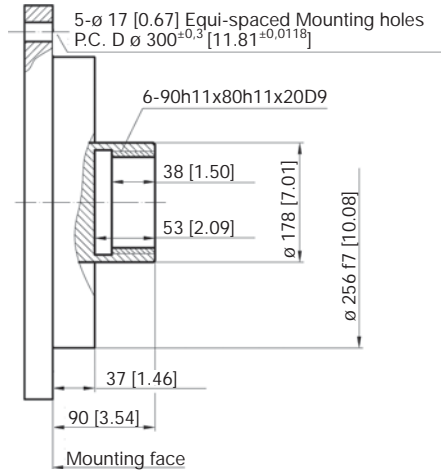

FS1111 6-90h11x80h11x20d9 female spline

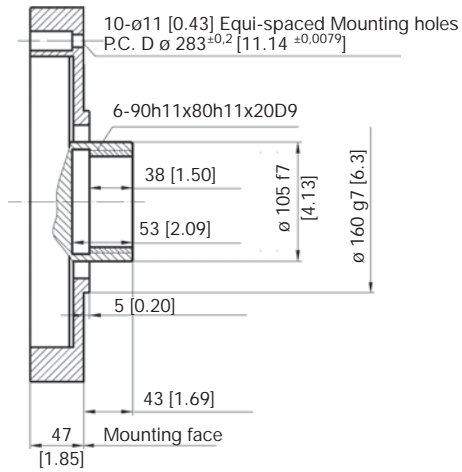

ASSEMBLY



New assembly facility will improve quality control, cleanliness of operation increase production. This most advanced equipment will permit our company to improve assembly operation while lowering cost.

YITM 16

YITM 16

TECHNICAL SPECIFICATIONS

TYPE	Displacement		Pressure				Torque				KW	HP	Speed Range r/min	Weight	
	mL/r	in ³ /rev	Rated pressure		Max Pressure		Rated Torque		Unit Torque					kg	lbs
			MPA	PSI	MPA	PSI	N.m	lb-ft	N.m/MPa	lb-ft/PSI					
YITM16-1400	1413	86.2	20	2900	30	4350	4191	3093	210	10.71	175	235	2 ~ 400	170	374
YITM16-1600	1648	100.5	20	2900	30	4350	4881	3602	244	12.44	197	264	2 ~ 400		
YITM16-1800	1814	110.7	18	2610	25	3625	4870	3594	268	13.69	161	216	2 ~ 320		
YITM16-2000	2034	124.1	16	2320	25	3625	4826	3562	301	15.35	157	210	2 ~ 320		
YITM16-2400	2267	138.3	16	2320	20	2900	5374	3966	335	17.08	137	184	2 ~ 250		

YITM 16

INSTALLATION DIMENSIONS

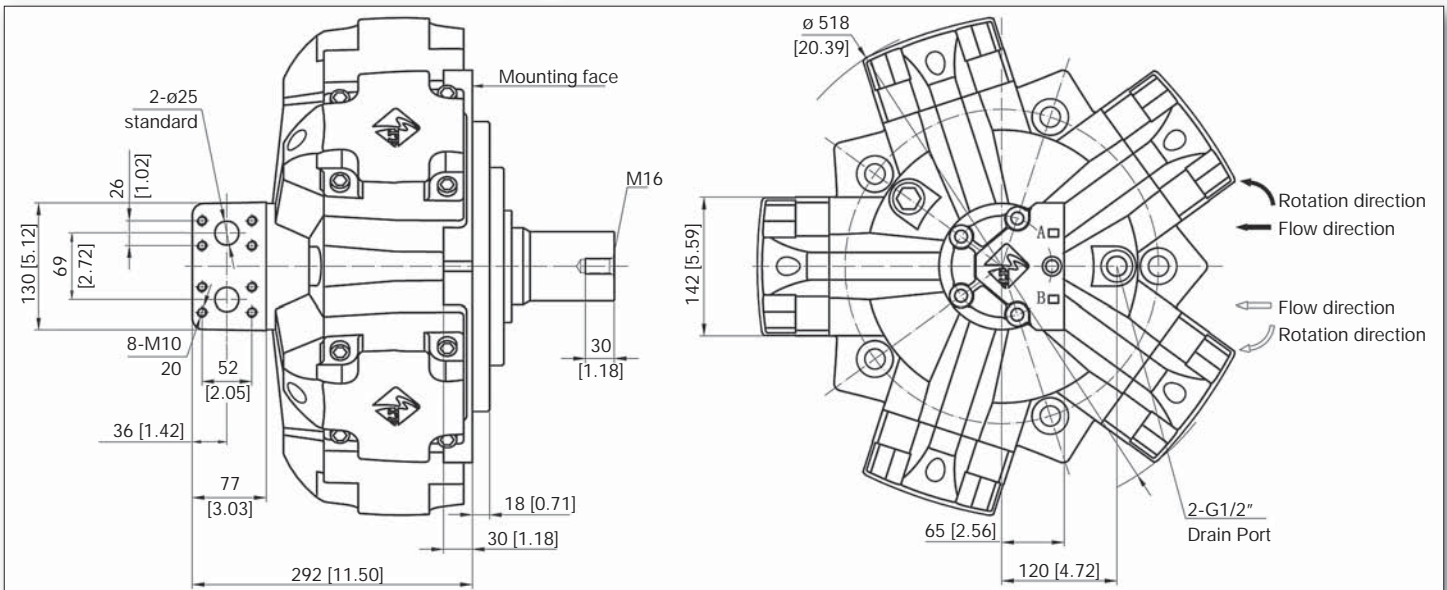

YITM 16

OUTPUT OPTIONS

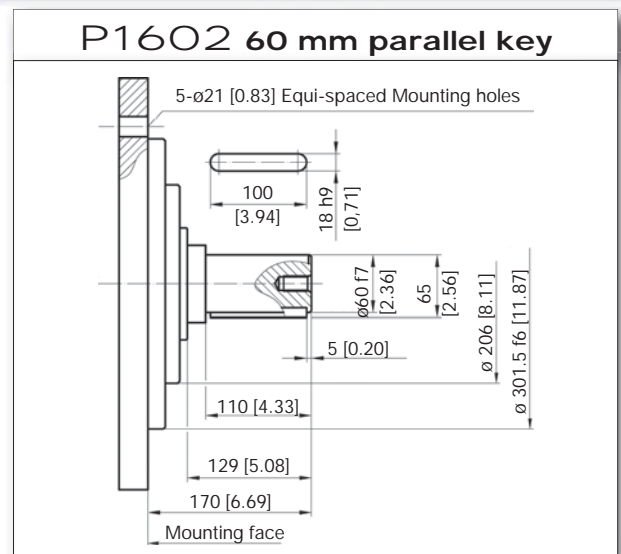
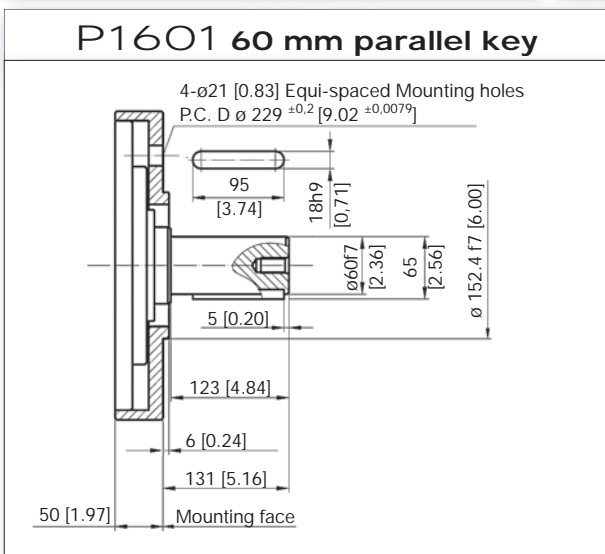

YITM 16

OUTPUT OPTIONS

P1603 72 mm parallel key

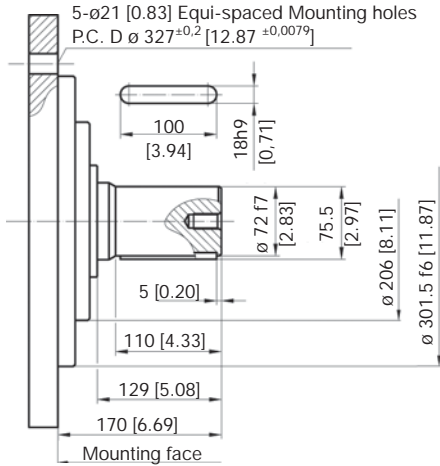

P1604 75 mm parallel shaft

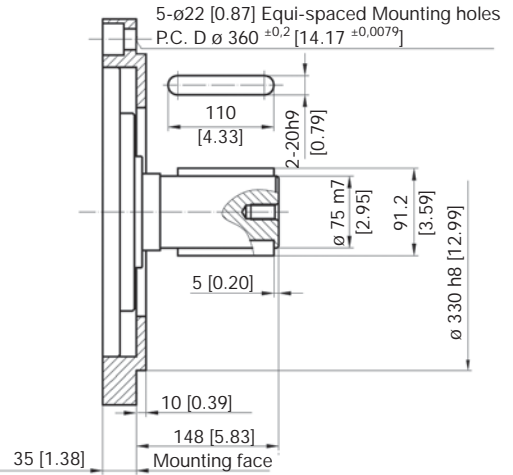

P1605 75 mm parallel shaft

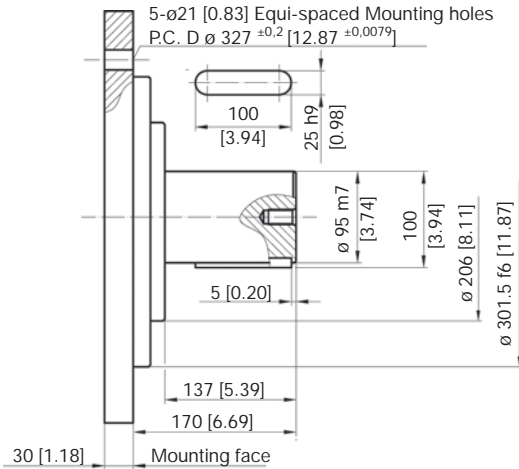

P1606 80 mm parallel shaft

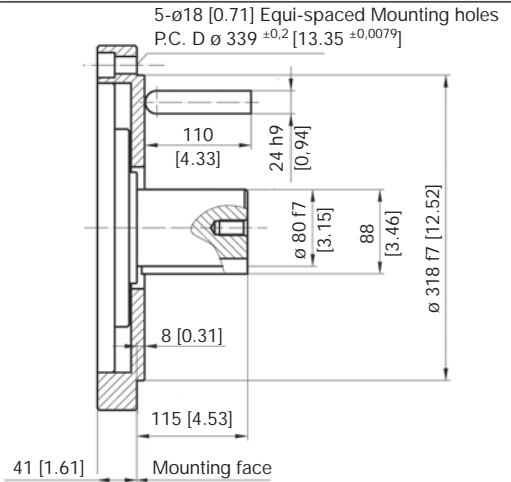

S1607 8-65d11x56d11x10f8

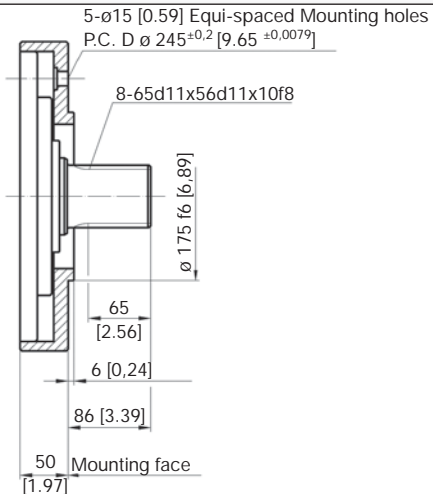

S1608 8-65d11x56d11x10f8

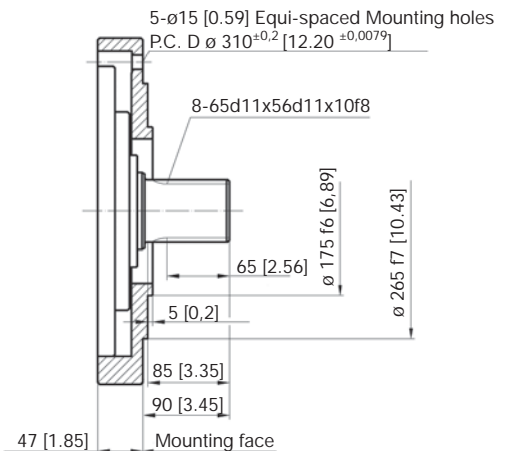

YITM 16

OUTPUT OPTIONS

S1609 8-72b12x62b12x12f8

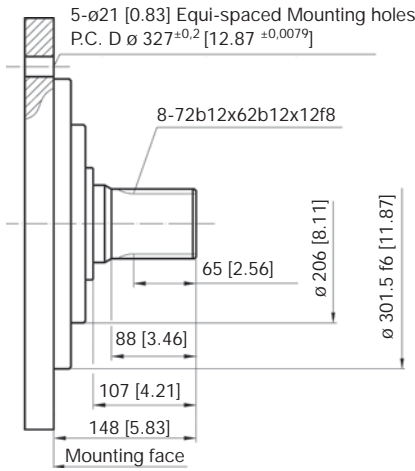

S1610 10-82b12x72b12x12f8

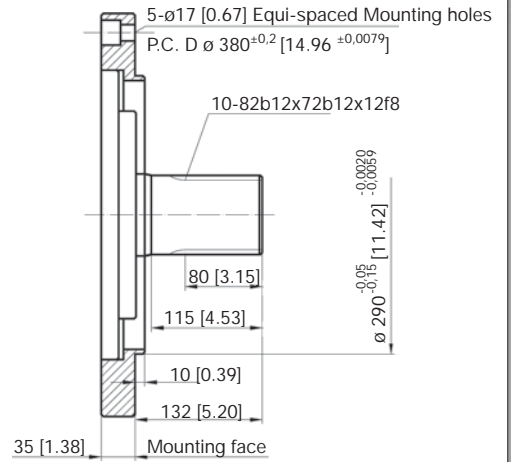

FS1611 10-98h11x92h11x14d9

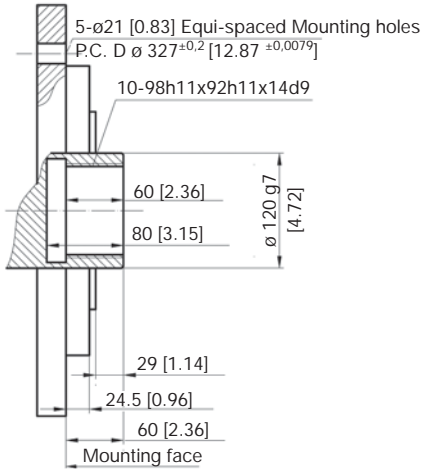

FS1612 10-98h11x92h11x14d9

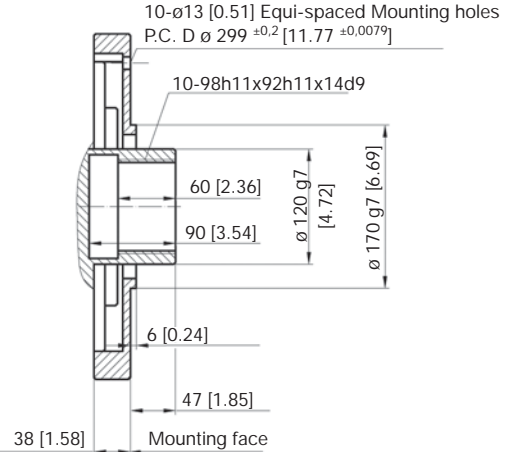

FS1613 12-98h11x92h11x14d9

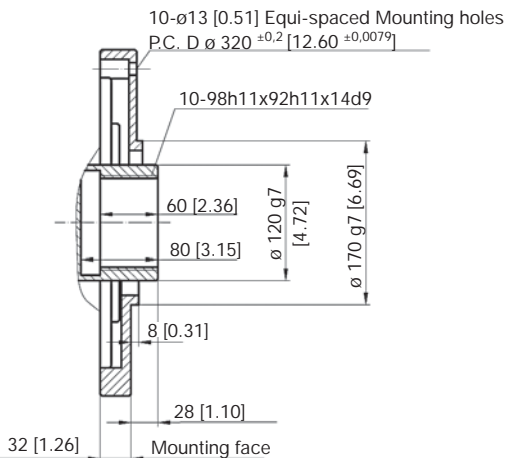

ENGINEERING



Our products are designed by experienced engineers, are manufactured with the most modern equipments, are tested with the most rigorous and stringent rules and guarantee a long and trouble free life.

YITM 31

YITM 31

TECHNICAL SPECIFICATIONS

TYPE	Displacement		Pressure				Torque				KW	HP	Speed Range r/min	Weight	
	mL/r	in ³ /rev	Rated pressure		Max Pressure		Rated Torque		Unit Torque					kg	lbs
			MPA	PSI	MPA	PSI	N.m	lb/ft	N.m/MPA	lb-ft/PSI					
YITM31-2500	2553	155.7	25	3625	32	4640	9523	7028	380	19.38	249	334	2 ~ 250	298	656
YITM31-2800	2683	163.7	25	3625	32	4640	10049	7416	401	20.45	207	277	1 ~ 200		
YITM31-3000	3063	186.9	20	2900	25	3625	9189	6782	459	23.41	191	256	1 ~ 200		
YITM31-3150	3218	196.3	20	2900	25	3625	9601	7086	480	24.48	196	263	1 ~ 200		
YITM31-3500	3462	211.2	20	2900	25	3625	10220	7542	511	26.06	171	229	1 ~ 160		
YITM31-4000	4152	253.3	20	2900	25	3625	12481	9211	624	31.82	205	275	1 ~ 160		
YITM31-5000	4828	294.6	16	2320	20	2900	11449	8449	715	36.46	187	251	1 ~ 160		

YITM 31

INSTALLATION DIMENSIONS

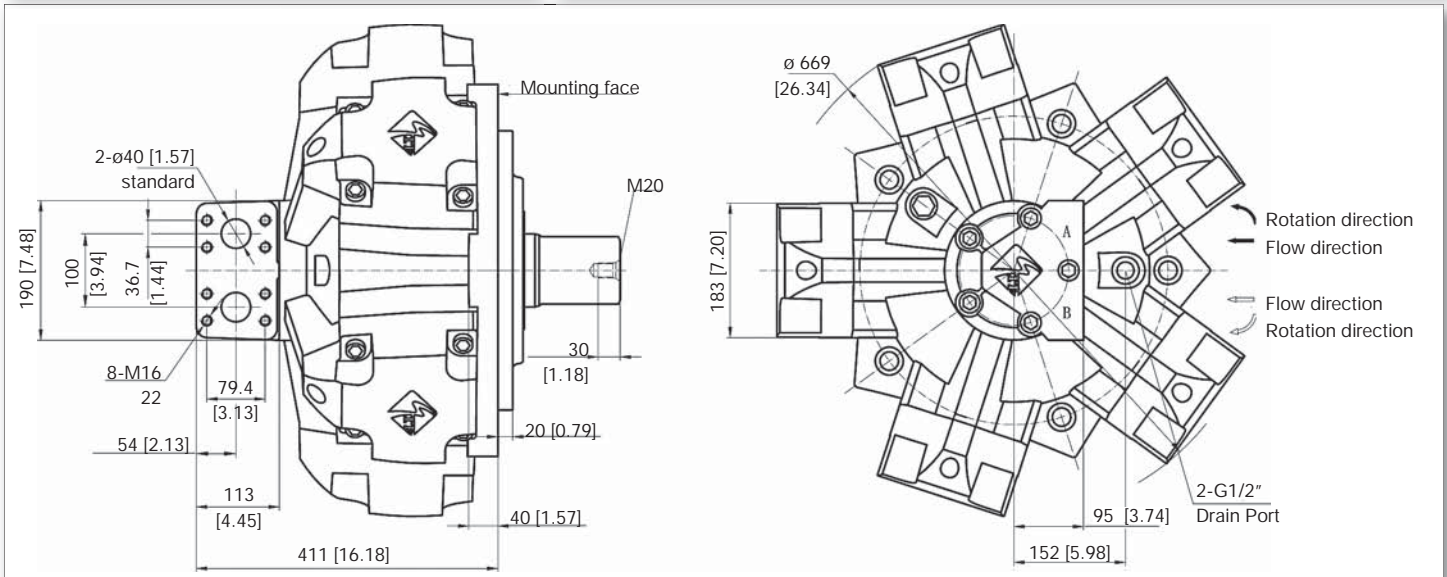

YITM 31

OUTPUT OPTIONS

P3101 85 mm parallel key

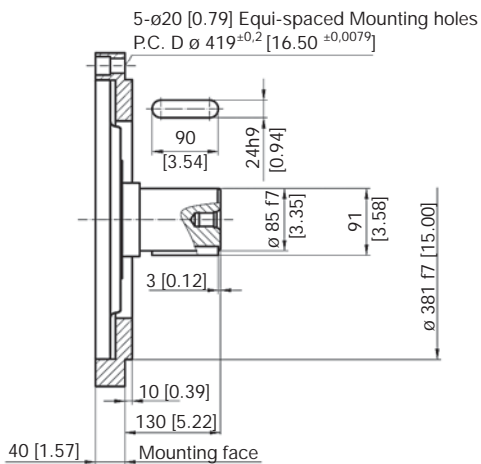

P3102 85 mm parallel key

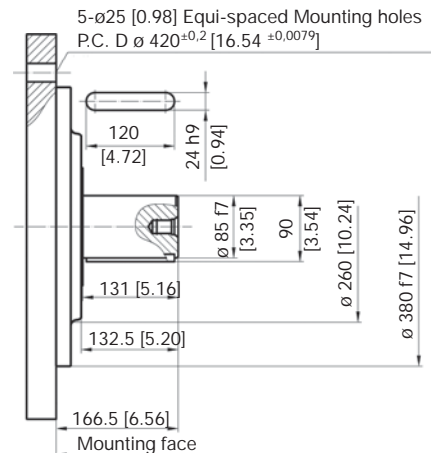

YITM 31

OUTPUT OPTIONS

P3103 85 mm parallel key

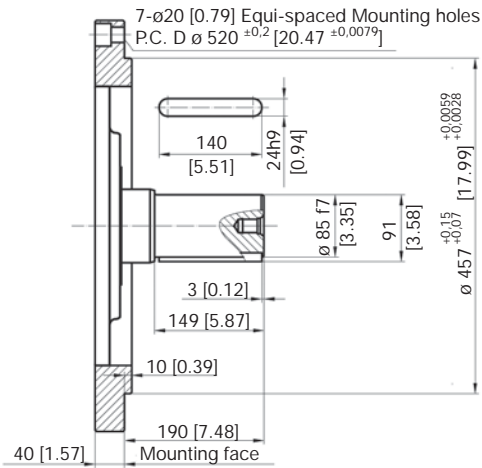

P3104 4.00" parallel shaft

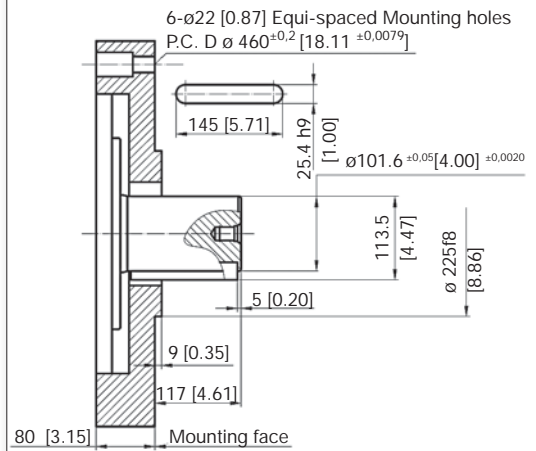

P3105 4.00" parallel shaft

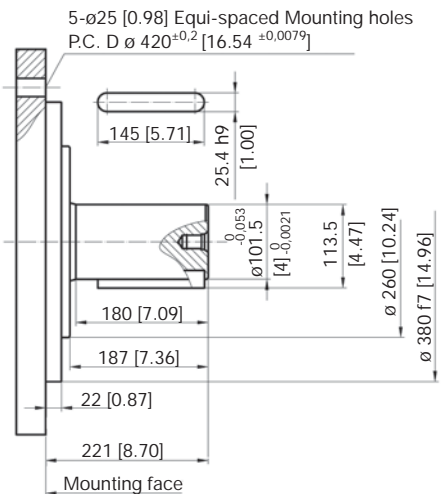

S 3106 10-88b12x8b12x12f8

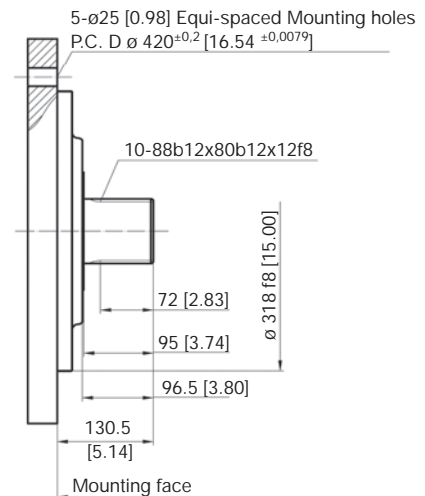

S 3107 10-92b12x82b12x12f8

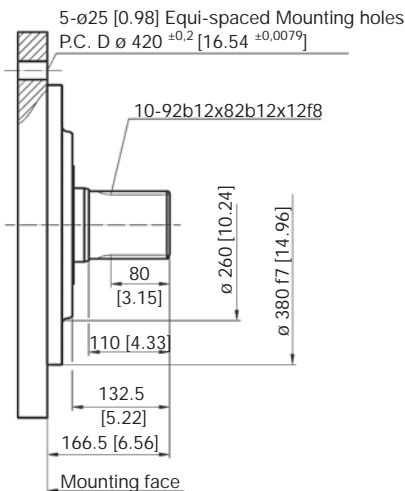

YITM

YITM 31

OUTPUT OPTIONS

FS 3108

10-98h11x92h11x14d9 female spline

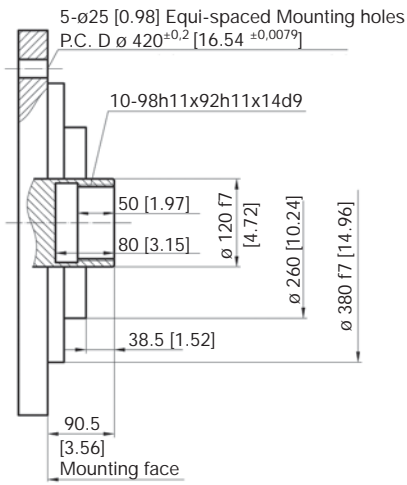

FS 3109

10-98h11x92h11x14d9 female spline

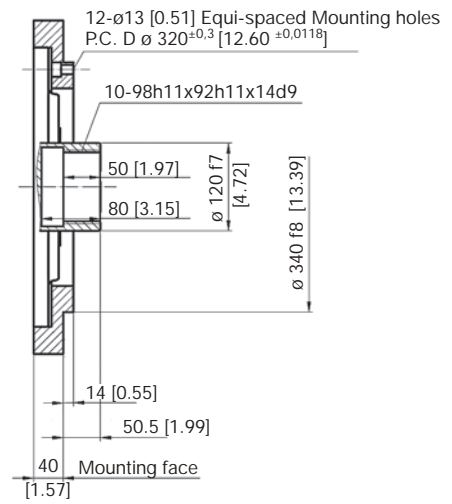

FS 3110

10-120h11x112h11x14d9 female spline

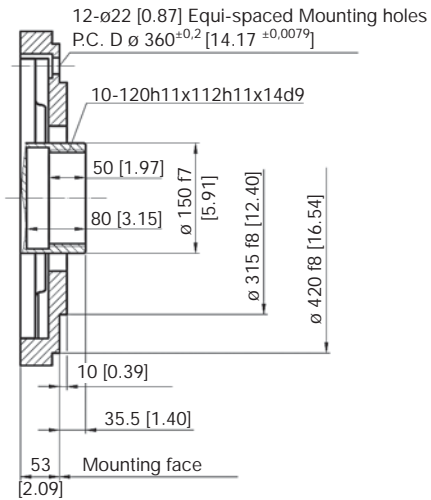

YITM 70

YITM 70

TECHNICAL SPECIFICATIONS

TYPE	Displacement		Pressure				Torque				KW	HP	Speed Range r/min	Weight	
	mL/r	in ³ /rev	Rated pressure		Max Pressure		Rated Torque		Unit Torque					kg	lbs
			MPA	PSI	MPA	PSI	N.m	lb/ft	N.m/MPA	lb-ft/PSI					
YITM70-5000	4946	301.8	20	2900	25	3625	14626	10794	731	37.28	220	295	1 ~ 160	550	1210
YITM70-5400	5452	332.6	20	2900	25	3625	16125	11900	806	41.10	243	326	1 ~ 160		
YITM70-6000	5984	365.1	20	2900	25	3625	17697	13061	885	45.13	208	279	0.5 ~ 125		
YITM70-6300	6540	399.0	18	2610	22.5	3262	17408	12847	967	49.32	205	275	0.5 ~ 125		
YITM70-7000	7122	434.5	16	2320	20	2900	16849	14649	1053	53.70	198	265	0.5 ~ 125		

YITM 70

INSTALLATION DIMENSIONS

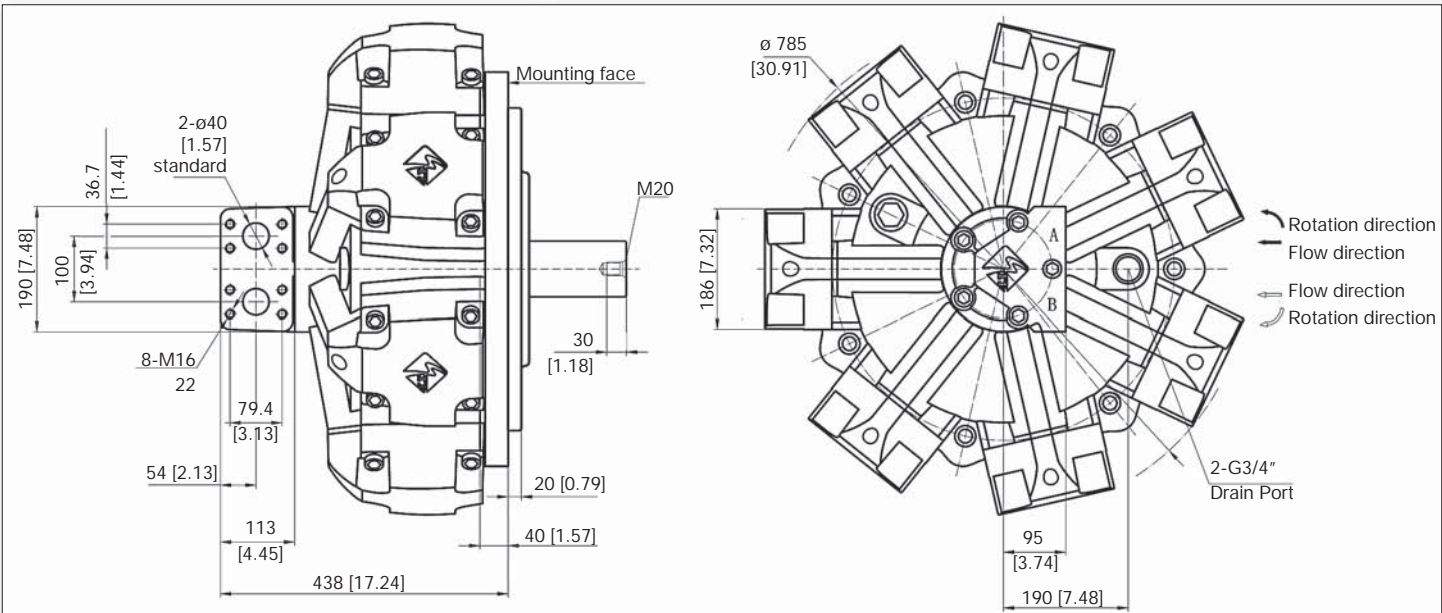

YITM 70

OUTPUT OPTIONS

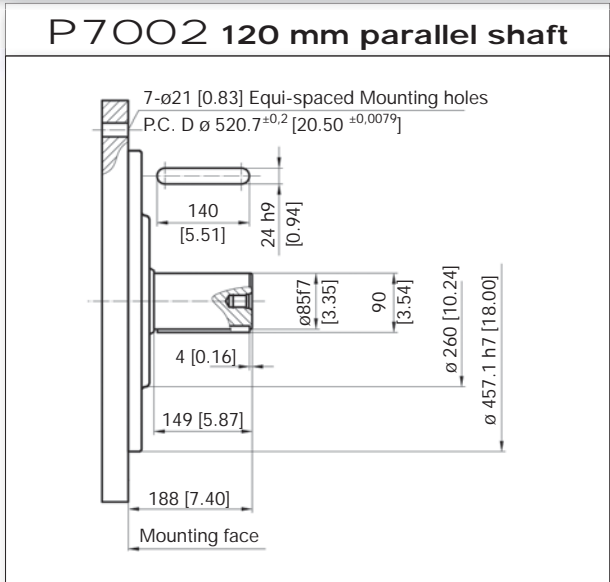
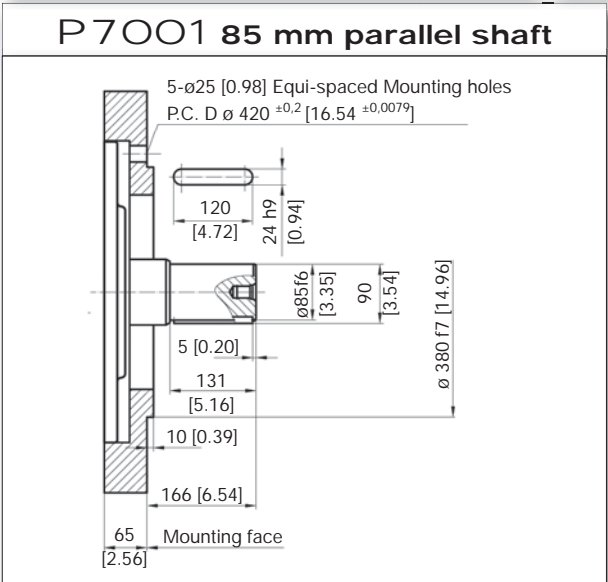

YITM 70

P7003 85 mm parallel key

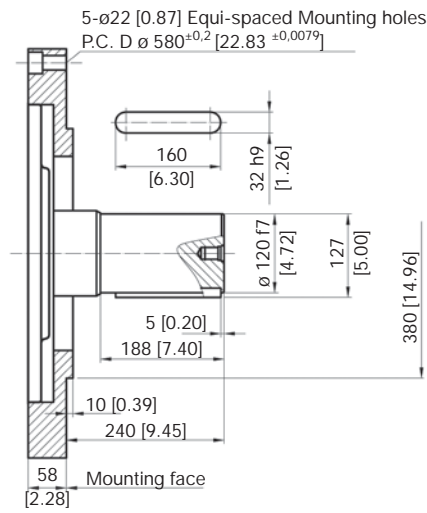

OUTPUT OPTIONS

S7004 10-102b12x112b12x16f8

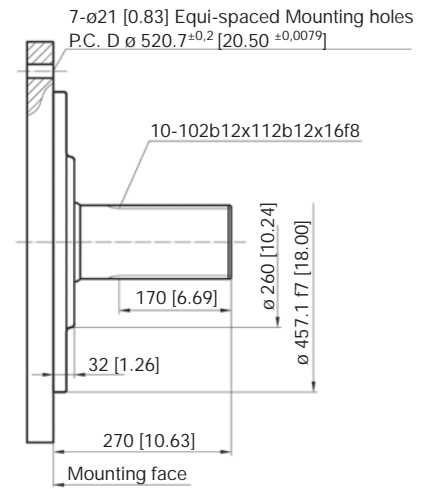

S7005 10-92b12x82b12x12f8

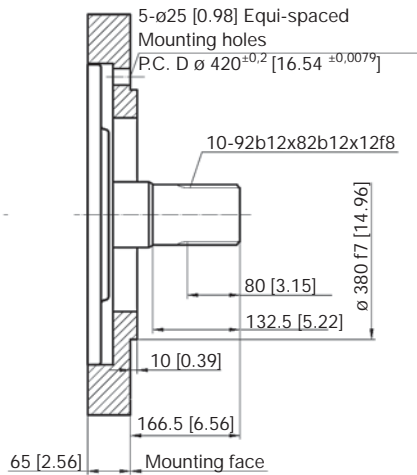

YITM 100

YITM 100

TECHNICAL SPECIFICATIONS

TYPE	Displacement		Pressure				Torque				KW	HP	Speed Range r/min	Weight	
	mL/r	in ³ /rev	Rated pressure		Max Pressure		Rated Torque		Unit Torque					kg	lbs
			MPA	PSI	MPA	PSI	N.m	lb/ft	N.m/MPA	lb-ft/PSI					
YITM100-6300	6758	412.3	20	2900	25	3625	19340	14273	967	49.32	226	303	0.5 ~ 125	830	1826
YITM100-7000	7390	450.8	20	2900	25	3625	21160	15616	1058	53.96	248	332	0.5 ~ 125		
YITM100-8000	7985	487.2	20	2900	25	3625	22896	16897	1145	58.39	269	360	0.5 ~ 125		
YITM100-9000	8636	526.9	20	2900	25	3625	24740	18258	1237	63.09	290	389	0.5 ~ 125		
YITM100-10000	10016	611.1	18	2610	25	3625	25758	19010	1431	72.98	245	328	0.5 ~ 100		

YITM 100

INSTALLATION DIMENSIONS

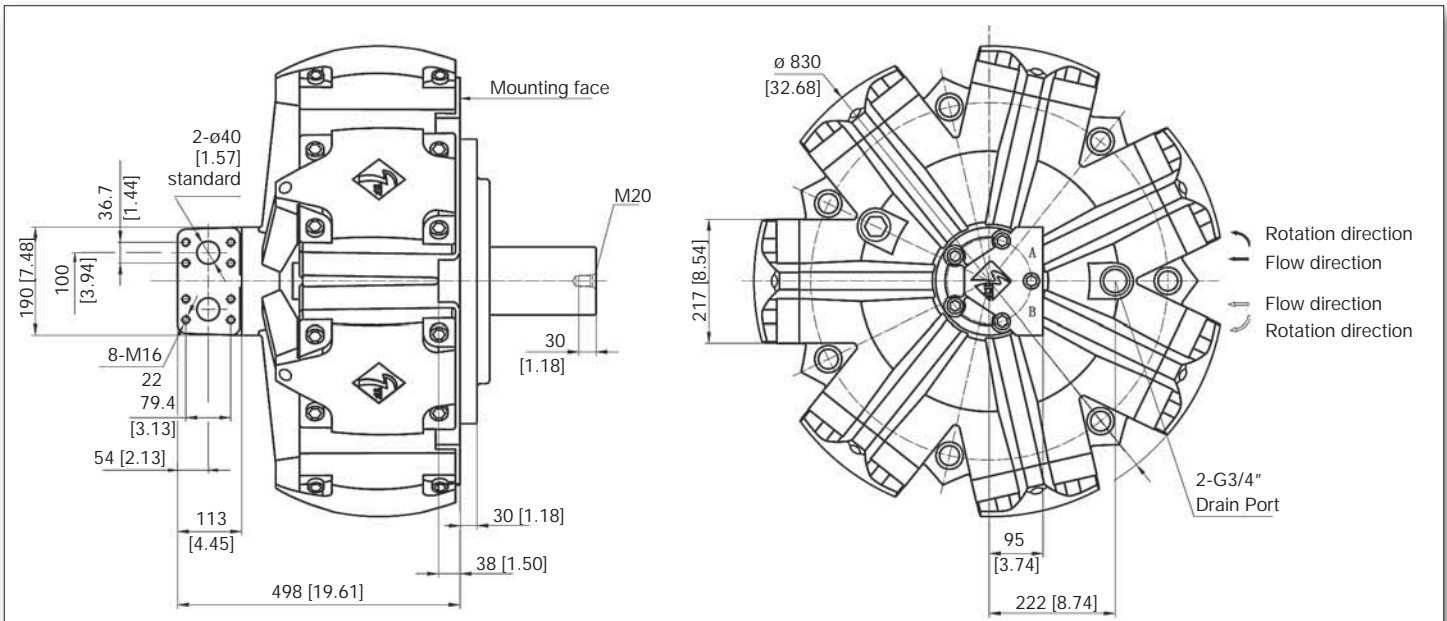

YITM 100

OUTPUT OPTIONS

P10001 120 mm parallel shaft

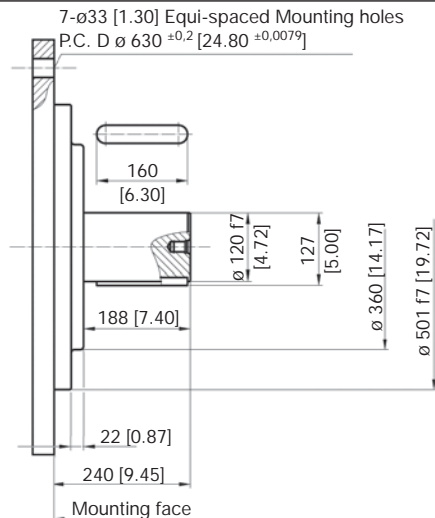

S10002 10-102b12x112b12x18f8

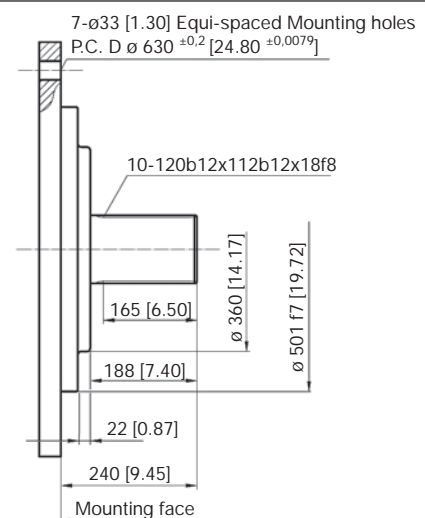

DISTRIBUTOR OPTIONS

YITM 100

DISTRIBUTOR TYPE	STANDARD THREAD		MOTOR TYPE	DISTRIBUTOR DIMENSION
D31	G 3/4"	3/4" BSPP Thread	YITM01	
	G 1"	1" BSPP Thread	YITM02	
	M 1	27x2 Metric	YITM03	
	M 2	33x2 Metric	YITM06	
D40	G 1"	1" BSPP Thread	YITM08	
	M 1	27x2 Metric	YITM11	
	M 2	33x2 Metric		
D47	C61	A-B ports 25 mm 4 Bolts flange code 61	YITM11	
	M 1	27x2 Metric	YITM16	
	M 2	33x2 Metric		
D90	C61	A-B ports 40 mm 4 Bolts flange code 62	YITM16	
	M 1	33x2 Metric	YITM31	
	M 2	42x2 Metric	YITM70 YITM100	

YITM

YITM

PORT ORIENTATION

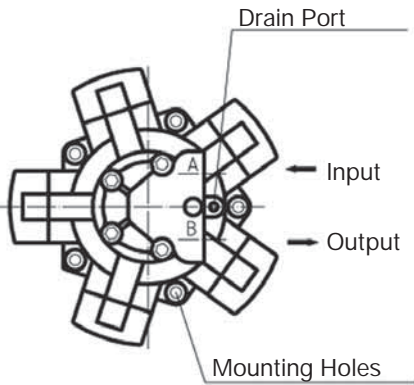

A-B 1

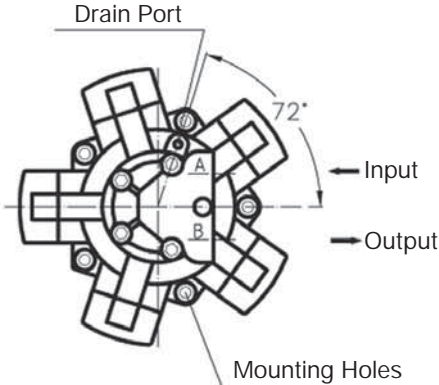

A-B 2

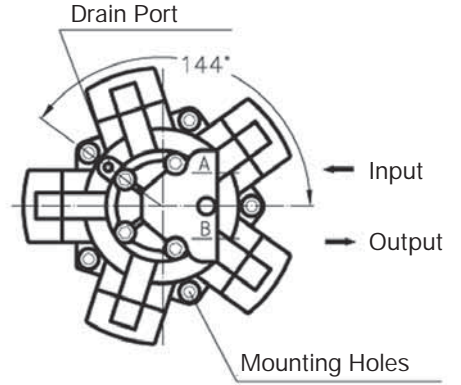

A-B 3

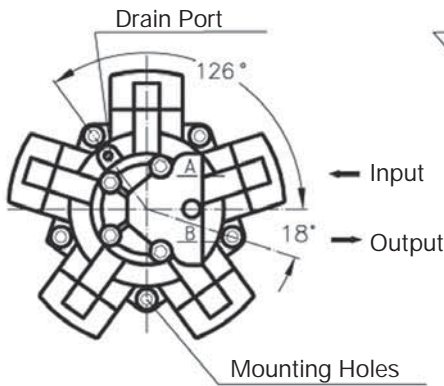

A-B 4

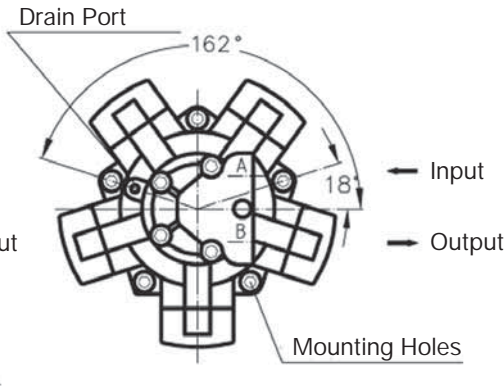

A-B 5

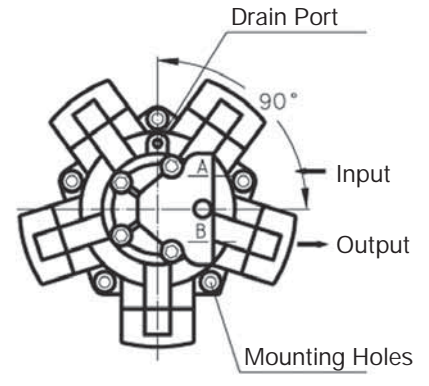

A-B 6

YITM

ORDERING CODE

YITM

YITM H ** *** *** ** * *

--	--	--	--	--	--	--	--

INPUT/OUTPUT PORT DIRECTION
 please see the illustration if there is no special indication. It means the motor mounting hole according to 72° on equispaced on PCD, oil input and output port direction follow 90°. 180° position change. The specific request can be confirmed by the port direction, please see Page 78 and state it in your orders

I/O PORT THREAD
 standard thread may not state. If you have special request, please see Page 22 and state it in your orders

DISTRIBUTORS
 (please see the graph of dimension of alla series of motors). If you have special request please see page 78 and state it ion your orders

OUTPUT SHAFT

1. No symbol--- standard rectangle spline shaft (the center is up to outside diameter)
2. B--Key shaft; footnote number means the installation dimension same as BM series motor or ither motor or other bands (with flange)
3. D--installation dimension same as 1 JMD series motor (KunSan HYD element plant)
4. I--inside spline (the center is up inner diameter); footnote number means the intallation dimension same as QJM series motor (with flange which produced by Ningbo hydraulic motor factory)
5. GM, SL--the installation dimension same as M series, L series of SAI ITALY, footnote number means different kinds of installation dimension

DISPLACEMENT (ml/r)

SERIES

MOTOR TYPE

1. no letter stands for standard hydraulic motor
2. H for high performance hydraulic motor

YITM/YITM model of STF hydraulic motor

YITM

HYDRAULIC MOTOR DATA SHEET

Date: _____
 Company _____
 Contact _____ Phone _____
 Machine _____ Model _____

Existing Motor Mfg _____
 Code _____
 Model # _____

Quantity _____ YSTFC _____
 Type _____ YSTFD _____
 Radial piston _____ YITM _____
 Displacement _____ Cu in/rev _____
 Max oil flow _____ GPM _____
 Max working pressure _____ PSI _____
 Nominal oil flow _____ GPM Porting _____
 Nominal working pressure _____ PSI Shaft _____
 Speed RPM cont Mnt Flange _____
 RPM int _____
 RPM peak _____

Is a drain line available? Yes No
 Type of flow circulation Closed Loop Open Loop
 Free-wheeling required Yes No

Max torque _____ lb/in
 Max fluid temp _____ F
 Additional application info. _____

Duty Cycle	% of Time	Torque lb/in	% of Time	Speed Rpm	% of Time
1					
2					
3					
4					

For Internal use: _____ Date: _____
 Selection _____
 Reviewed by _____
 Approved by _____







3060 Plaza Dr. • Unit 107

Garnet Valley, PA 19061

Tel: (610)558-0760

Fax: (610)558-0762

www.youngpowertechinc.com

LIMITED ONE YEAR WARRANTY FOR HYDRAULIC MOTORS

If the hydraulic motor (product) fails to function within one (1) year after the date of its original shipment, or invoice date whichever come first, due to a defect in the materials or workmanship, Young Powertech Inc. (YPT) will remedy the defect without charge to the consumer purchaser. The foregoing limited warranty does not cover failure to function caused by damage to the product while in your possession, improper installation, unreasonable use or abuse of the product, failure to provide or use of improper maintenance, failure to follow written installation and instructions, or any use other than for personal, family or household purposes. THE REMEDIES PROVIDED IN THE ABOVE EXPRESS LIMITED WARRANTY ARE THE SOLE AND EXCLUSIVE REMEDIES AVAILABLE TO YOU. NO OTHER EXPRESS WARRANTIES ARE MADE. ALL IMPLIED WARRANTIES, INCLUDING BUT NOT LIMITED TO ANY IMPLIED WARRANTY OF MERCHANTABILITY OR FITNESS FOR A PARTICULAR PURPOSE OR USE, ARE LIMITED IN DURATION AS SET FORTH ABOVE. IN NO EVENT SHALL YPT BE LIABLE FOR ANY INCIDENTAL OR CONSEQUENTIAL DAMAGES. Some states do not allow limitations on how long an implied warranty lasts or do not allow the exclusion or limitation of incidental or consequential damages, so the above limitations or exclusions may not apply to you. This warranty gives you specific legal rights and you may also have other rights which vary from state to state. The consumer-purchaser must maintain proof of purchase and shipment date of the product to prove the date of purchase and shipment in the unlikely event of a warranty claim. In order to obtain a return authorization number you must contact Young Powertech Inc. at 610-558-0760 prior to shipping. The customer will be required to ship only the defective parts, freight pre-paid to :

Young Powertech Inc
3060 Plaza Dr.
Unit 107
Garnet Valley, PA 19061

Young Powertech Inc, will repair or replace any part found defective and return the unit prepaid by ground shipment to the customer.

In the event that the unit is not found to have a defect the customer will be charged an inspection fee and the unit will be returned freight collect to the customer.



Young Powertech Inc
3060 Plaza Drive # 107
Garnet Valley PA 19060
Tel: (610) 558-0760
Fax: (610) 558-0762
e-mail: info@yptius.com